

Technical Support Center: Synthesis of Asymmetric N-Substituted Phthalimides

Author: BenchChem Technical Support Team. **Date:** May 2026

Compound of Interest

Compound Name:	<i>2-Aminoisoindoline-1,3-dione hydrochloride</i>
CAS No.:	1198286-64-4
Cat. No.:	B175618

[Get Quote](#)

Welcome to the technical support center for the synthesis of asymmetric N-substituted phthalimides. This guide is designed for researchers, medicinal chemists, and process development scientists who encounter challenges in the stereocontrolled synthesis of these valuable chiral building blocks. As a Senior Application Scientist, my goal is to provide not just protocols, but the underlying chemical principles and field-proven insights to help you troubleshoot and optimize your reactions effectively.

This center is structured to address issues from multiple perspectives, starting with high-level frequently asked questions and moving into detailed troubleshooting for specific reaction types and challenges.

Part 1: Frequently Asked Questions (FAQs)

This section addresses common questions and strategic decisions in the synthesis of asymmetric N-substituted phthalimides.

Q1: Why is the direct alkylation of a chiral amine not always preferred over using a phthalimide-based method?

A1: Direct alkylation of primary amines with alkyl halides is notoriously difficult to control. The product, a secondary amine, is often more nucleophilic than the starting primary amine, leading to over-alkylation and the formation of tertiary amines and even quaternary ammonium salts.^[1] The Gabriel synthesis, which utilizes potassium phthalimide as an ammonia surrogate, elegantly circumvents this issue.^[1] The phthalimide's two electron-withdrawing carbonyl groups decrease the nucleophilicity of the nitrogen atom in the N-substituted product, preventing further alkylation.^[1]

Q2: What are the primary strategies for introducing asymmetry in N-substituted phthalimide synthesis?

A2: There are three main strategies:

- **Substrate-Controlled (Diastereoselective) Synthesis:** This involves reacting potassium phthalimide with a chiral electrophile (e.g., a chiral alkyl halide or sulfonate). The stereocenter is already present in the reactant.
- **Auxiliary-Controlled (Diastereoselective) Synthesis:** A chiral auxiliary is attached to the phthalimide or the electrophile to direct the stereochemical outcome of the N-alkylation step. The auxiliary is removed in a subsequent step.
- **Catalyst-Controlled (Enantioselective) Synthesis:** A chiral catalyst is used to control the approach of the phthalimide nucleophile to a prochiral electrophile, creating a new stereocenter with a preference for one enantiomer. This is a highly efficient approach but can be sensitive to reaction conditions.

Q3: My target molecule has a stereocenter that is prone to racemization. Which deprotection method is safest?

A3: Traditional deprotection methods involving strong acids or bases can be harsh. For substrates with sensitive stereocenters, especially α -amino acids, milder, near-neutral methods are highly recommended to prevent racemization.^{[2][3]}

- Ing-Manske Procedure: This method uses hydrazine (N_2H_4) in a refluxing solvent like ethanol. It's a classic and effective method, but removing the phthalhydrazide byproduct can be challenging.[1]
- Sodium Borohydride ($NaBH_4$) / Acetic Acid: This is an exceptionally mild, two-stage, one-pot procedure that has been shown to deprotect phthalimides of α -amino acids with no measurable loss of optical activity.[2][4] The reaction proceeds through the reduction of the phthalimide to an o-hydroxymethyl benzamide, which then lactonizes to release the free amine and phthalide, a byproduct that is often easier to remove than phthalhydrazide.[2]

Q4: Can I use secondary or tertiary alkyl halides in the Gabriel synthesis?

A4: It is generally not recommended. The Gabriel synthesis proceeds via an S_N2 mechanism. Secondary and especially tertiary alkyl halides are sterically hindered, which dramatically slows the rate of substitution. Furthermore, the phthalimide anion, while a good nucleophile, is also a reasonably strong base, leading to competing E2 elimination reactions that form alkenes as the major side products.

Part 2: Troubleshooting Guides

This section provides detailed troubleshooting for common issues encountered during the key steps of asymmetric N-substituted phthalimide synthesis.

Guide 1: Asymmetric N-Alkylation Reactions (Low Stereoselectivity)

Achieving high enantiomeric or diastereomeric excess (ee/de) is the primary challenge in asymmetric synthesis. Low stereoselectivity is a common and frustrating issue.

Problem	Potential Cause(s)	Recommended Solution(s)
Low Diastereomeric Excess (de) in Auxiliary-Controlled Alkylation	<p>1. Incorrect Base/Solvent Combination: The geometry of the enolate (or equivalent) formed during deprotonation is critical for facial selectivity and is highly dependent on the base and solvent.</p>	<p>1. Optimize Deprotonation: For Evans-type oxazolidinone auxiliaries, sodium hexamethyldisilazide (NaHMDS) in THF at -78 °C is a standard starting point for generating the Z-enolate, which typically leads to high diastereoselectivity.</p>
	<p>2. Non-Chelating vs. Chelating Conditions: The metal counterion of the base can influence the conformation of the transition state. Li-bases (e.g., LDA) often form tight, chelated transition states, while Na- or K-bases form more open, non-chelated transition states, which can lead to different stereochemical outcomes.</p>	<p>2. Screen Metal Counterions: If low de is observed with LDA, switch to NaHMDS or KHMDS to favor a different transition state geometry.</p>
	<p>3. Reaction Temperature Too High: Higher temperatures can provide enough energy to overcome the activation barrier for the formation of the undesired diastereomer, eroding selectivity.</p>	<p>3. Maintain Low Temperatures: Ensure the reaction is maintained at the optimal low temperature (typically -78 °C) throughout the addition of the base and the electrophile.</p>
Low Enantiomeric Excess (ee) in Catalytic Alkylation	<p>1. Catalyst Poisoning or Deactivation: Impurities in the starting materials or solvent (e.g., water, other nucleophiles) can poison the chiral catalyst.</p>	<p>1. Ensure Anhydrous Conditions: Use freshly distilled, anhydrous solvents. Ensure starting materials are pure and dry. The use of</p>

molecular sieves can be beneficial.

2. Suboptimal Catalyst

Loading or Ligand-to-Metal Ratio: The concentration and stoichiometry of the catalyst components are crucial for forming the active chiral complex.

2. Optimize Catalyst System: Systematically screen catalyst loading (e.g., 1-10 mol%) and ligand-to-metal ratios to find the optimal conditions for your specific substrate.

3. Background Uncatalyzed

Reaction: A non-selective background reaction can compete with the desired catalytic cycle, leading to a racemic product and lowering the overall ee.

3. Lower Reaction

Temperature: Reducing the temperature can slow down the uncatalyzed reaction more significantly than the catalyzed one, improving ee. Also, ensure slow addition of reagents.

Racemization of Product

1. Atropisomeric Instability: For N-aryl phthalimides, the rotational barrier around the C-N bond may be too low at the reaction or workup temperature, leading to racemization.

1. Thermal Stability Analysis: Assess the thermal stability of the chiral axis. If racemization occurs at elevated temperatures, ensure all subsequent steps and purification are performed at lower temperatures.^[5]

2. Epimerization during

Workup/Purification: An acidic or basic proton on the chiral substituent can be removed during workup or chromatography on silica gel, leading to epimerization.

2. Neutralize Workup: Use a mild, neutral workup. For chromatography, consider using deactivated silica gel (e.g., by adding 1% triethylamine to the eluent for basic compounds) or switching to a different stationary phase like alumina.

Guide 2: The Mitsunobu Reaction for N-Alkylation

The Mitsunobu reaction is a powerful method for converting a chiral secondary alcohol directly to the corresponding N-phthalimido derivative with inversion of stereochemistry.^[6] However, it has several common failure points.

Problem	Potential Cause(s)	Recommended Solution(s)
Low or No Conversion to Product	1. Alcohol is Too Sterically Hindered: The S _N 2-like displacement at the alcohol's carbon is sensitive to steric bulk.	1. Increase Reaction Time/Temperature: For moderately hindered alcohols, prolonged reaction times or a modest increase in temperature (e.g., from 0 °C to room temperature) may be sufficient. [6]
Borderline: The nucleophile must be deprotonated by the betaine intermediate. Phthalimide (pK _a ≈ 8.3) is generally acidic enough, but if the reaction is sluggish, this could be a factor.	2. Use Pre-formed Potassium Phthalimide: Instead of phthalimide, use potassium phthalimide. This bypasses the in-situ deprotonation step.	
3. Incorrect Order of Reagent Addition: The standard and generally most reliable order is to have the alcohol, phthalimide, and triphenylphosphine (PPh ₃) in solution before the dropwise addition of the azodicarboxylate (DEAD or DIAD).	3. Follow Standard Protocol: Dissolve alcohol, phthalimide, and PPh ₃ in an anhydrous solvent (THF is common) and cool to 0 °C before slowly adding the azodicarboxylate. [7]	
Formation of Side Products (e.g., Alkenes)	1. Elimination Competes with Substitution: This is more common with sterically hindered secondary alcohols where the alkoxyphosphonium intermediate undergoes E2 elimination.	1. Use Less Hindered Reagents: Consider using a less bulky phosphine if possible. Ensure the reaction is run at the lowest effective temperature.

Difficult Purification	1. Triphenylphosphine Oxide (TPPO) Removal: TPPO is a common byproduct and can be difficult to separate from the desired product due to its polarity.	1. Precipitation/Filtration: After the reaction, dilute with a less polar solvent like diethyl ether or a hexanes/ether mixture and cool. TPPO may precipitate and can be removed by filtration.[7]
2. Reduced Azodicarboxylate (Hydrazide) Removal: The dialkyl hydrazinedicarboxylate byproduct can also complicate purification.	2. Acidic Wash: Perform an aqueous workup with a dilute acid wash (e.g., 1M HCl) to protonate and extract the basic hydrazide byproduct into the aqueous layer.	
3. Use Modified/Resin-Bound Reagents: Consider using resin-bound PPh ₃ or modified azodicarboxylates designed for easier removal of byproducts.		

Guide 3: Deprotection and Product Isolation

The final deprotection step is critical for isolating the desired chiral primary amine in high yield and purity, without compromising its stereochemical integrity.

Problem	Potential Cause(s)	Recommended Solution(s)
Incomplete Deprotection	1. Insufficient Reagent or Reaction Time: Hydrazinolysis can sometimes be sluggish, especially if the substrate is sterically hindered or has poor solubility.	1. Increase Equivalents/Time: Increase the equivalents of hydrazine (e.g., up to 40 eq. for difficult substrates) and/or extend the reflux time.[8] Monitor the reaction by TLC or LCMS.
Difficulty Removing Phthalhydrazide Byproduct	1. Precipitate is Finely Divided or Colloidal: The phthalhydrazide precipitate can be difficult to filter effectively, leading to contamination of the filtrate.	1. Acidify then Filter: After cooling the reaction mixture, add dilute HCl. This protonates the desired amine, making it soluble in the aqueous/alcoholic medium, while the phthalhydrazide remains insoluble and can be more effectively filtered off.
2. Byproduct Co-extracts with Product: During workup, the byproduct may have some solubility in the organic phase.	2. Optimize Extraction: After removing the solvent, dissolve the residue in a suitable organic solvent and wash thoroughly with a dilute base (e.g., 5% NaHCO ₃ or 1M NaOH). The phthalhydrazide is acidic and will be extracted into the basic aqueous layer.[3]	
Low Yield of Isolated Amine	1. Product Loss during Workup: The free amine may be volatile or have some water solubility, leading to loss during extraction and solvent removal steps.	1. Convert to Salt: After deprotection, perform an acidic workup to convert the amine to its non-volatile hydrochloride salt. The salt can then be isolated, or the aqueous solution can be basified and immediately extracted.

Racemization of the Chiral Center

1. Harsh Deprotection
Conditions: Use of strong acid or base for hydrolysis can lead to epimerization, especially at an α -carbon to a carbonyl or other activating group.

1. Switch to Milder Methods:
Use the Ing-Manske (hydrazine) procedure or, preferably, the NaBH_4 /acetic acid method, which is known to preserve stereochemical integrity.[2]

Part 3: Experimental Protocols & Data

Protocol 1: General Procedure for Gabriel Synthesis

This protocol describes the N-alkylation of potassium phthalimide with a primary alkyl halide.

- Setup: To a flame-dried round-bottom flask under an inert atmosphere (N_2 or Ar), add potassium phthalimide (1.0 eq.).
- Solvent Addition: Add a suitable polar aprotic solvent, such as DMF or DMSO (approx. 0.2-0.5 M concentration).
- Electrophile Addition: Add the primary alkyl halide or tosylate (1.0-1.2 eq.) to the suspension.
- Reaction: Heat the reaction mixture (typically 60-100 °C) and monitor its progress by TLC or LCMS.
- Workup: Once the reaction is complete, cool the mixture to room temperature and pour it into ice water. The N-substituted phthalimide product will often precipitate and can be collected by filtration.
- Purification: The crude solid can be further purified by recrystallization, typically from solvents like ethanol or an ethyl acetate/hexanes mixture.[9]

Protocol 2: Mitsunobu Reaction with a Chiral Secondary Alcohol

This protocol details the synthesis of an N-substituted phthalimide from a chiral secondary alcohol with stereochemical inversion.

- **Setup:** To a flame-dried, three-neck round-bottom flask equipped with a thermometer and under an inert atmosphere, add the chiral secondary alcohol (1.0 eq.), phthalimide (1.2 eq.), and triphenylphosphine (1.2 eq.).
- **Solvent & Cooling:** Dissolve the solids in anhydrous THF (0.1-0.2 M) and cool the solution to 0 °C using an ice bath.
- **Azodicarboxylate Addition:** Slowly add diisopropyl azodicarboxylate (DIAD) or diethyl azodicarboxylate (DEAD) (1.2 eq.) dropwise via syringe, ensuring the internal temperature does not rise significantly.
- **Reaction:** Allow the reaction to warm to room temperature and stir for 4-16 hours. Monitor by TLC for the consumption of the alcohol and the formation of a higher R_f product.
- **Workup:** Concentrate the reaction mixture under reduced pressure. Add diethyl ether to the residue to precipitate the triphenylphosphine oxide byproduct. Filter and concentrate the filtrate.
- **Purification:** Purify the crude product by flash column chromatography on silica gel. A common eluent system is a gradient of ethyl acetate in hexanes.[10]

Protocol 3: Mild Deprotection using NaBH₄/Acetic Acid

This protocol is ideal for sensitive substrates where racemization is a concern.[2]

- **Reduction:** Dissolve the N-substituted phthalimide (1.0 eq.) in 2-propanol or THF. Add sodium borohydride (NaBH₄) (2.0-3.0 eq.) portion-wise at room temperature.
- **Monitoring:** Stir the reaction until TLC indicates the complete consumption of the starting material.
- **Acidification & Amine Release:** Cool the mixture in an ice bath and slowly add acetic acid until the quenching of excess NaBH₄ ceases and the pH is acidic. Stir for 1-2 hours as the intermediate lactonizes to release the amine.
- **Workup:** Remove the solvent under reduced pressure. Dissolve the residue in water and perform an acid/base extraction.

- Wash with diethyl ether or dichloromethane to remove the phthalide byproduct.
- Basify the aqueous layer with NaOH or Na₂CO₃.
- Extract the liberated amine with an organic solvent (e.g., dichloromethane or ethyl acetate).
- Isolation: Dry the combined organic extracts over Na₂SO₄, filter, and concentrate to yield the purified primary amine.

Data Summary: Comparison of Deprotection Methods

Method	Reagents	Typical Conditions	Advantages	Disadvantages	Ref.
Hydrazinolysis (Ing-Manske)	Hydrazine (N ₂ H ₄ ·H ₂ O)	Reflux in EtOH or THF, 4-24h	Effective for most substrates; avoids strong acids/bases.	Phthalhydrazide byproduct can be difficult to remove; hydrazine is toxic.	[1]
Acid Hydrolysis	Conc. HCl or H ₂ SO ₄	Reflux, prolonged heating	Harsh conditions can cleave other functional groups and cause racemization.		
Base Hydrolysis	NaOH or KOH	Reflux in H ₂ O/EtOH	Harsh conditions, risk of racemization.		
Sodium Borohydride	NaBH ₄ , then Acetic Acid	2-propanol/THF, RT then 0°C	Very mild, near-neutral; preserves stereocenters; easier byproduct removal.	Requires a two-stage, one-pot procedure.	[2][4]
Ammonium Hydroxide/Methylamine (AMA)	NH ₄ OH / MeNH ₂	RT, 10 min - 2h	Very fast deprotection.	Primarily used in solid-phase oligonucleotide synthesis; may not be	[11]

suitable for all
substrates.

Part 4: Visualization of Key Workflows

Workflow 1: The Gabriel Synthesis Pathway

This diagram illustrates the two-stage process of forming a primary amine via the Gabriel Synthesis.

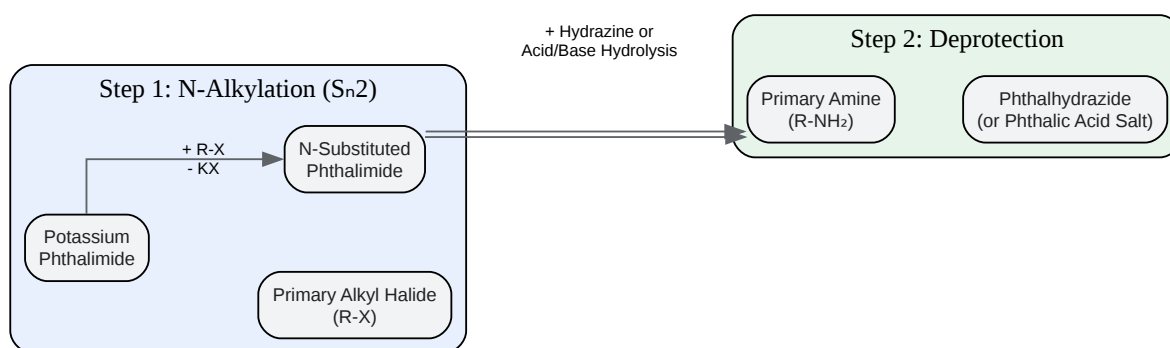

[Click to download full resolution via product page](#)

Caption: General workflow for the Gabriel Synthesis.

Workflow 2: The Mitsunobu Reaction for Asymmetric Synthesis

This diagram shows the key transformation in a Mitsunobu reaction for inverting a chiral alcohol.

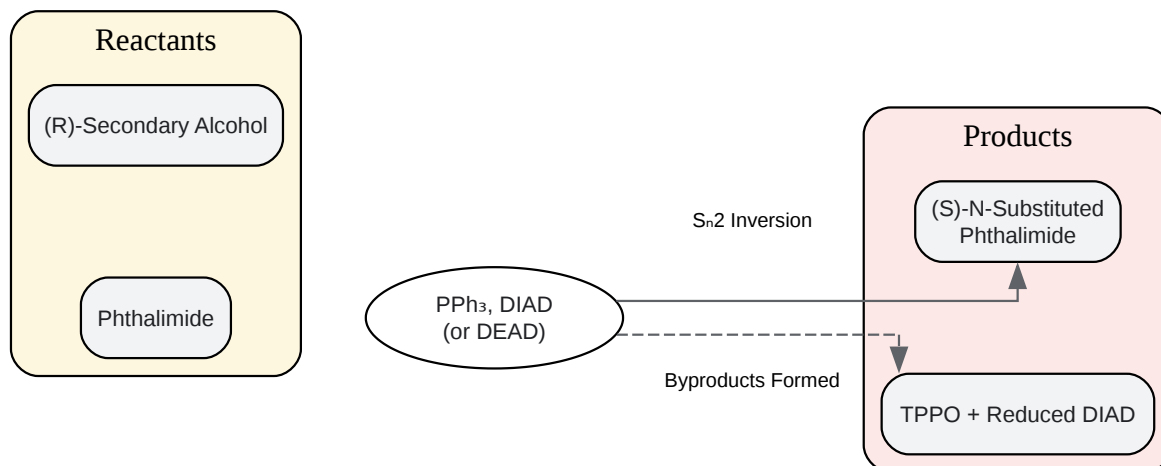

[Click to download full resolution via product page](#)

Caption: Stereoinversive synthesis via the Mitsunobu reaction.

References

- Hughes, D. L. The Mitsunobu Reaction. *Organic Reactions*. 1992, 42, 335–656. [[Link](#)]
- Ashenhurst, J. The Gabriel Synthesis. *Master Organic Chemistry*. 2025. [[Link](#)]
- Osby, J. O.; Martin, M. G.; Ganem, B. An exceptionally mild deprotection of phthalimides. *Tetrahedron Letters*. 1984, 25(19), 2093–2096. [[Link](#)]
- Barik, S.; Ranganathappa, S. S.; Biju, A. T. Atroposelective Synthesis of N-Aryl Phthalimides and Maleimides via NHC-Catalyzed Activation of Carboxylic Acids. *ChemRxiv*. 2024. [[Link](#)]
- Various Authors. Phthalimides. *Organic Chemistry Portal*. [[Link](#)]
- Various Authors. Mitsunobu reaction. *Organic Synthesis*. [[Link](#)]
- Various Authors. Deprotection conditions for phthalimide protected oxyamine? *Reddit r/Chempros*. 2023. [[Link](#)]

- Various Authors. Supporting Information - General procedure for the deprotection of the phthalimide. Royal Society of Chemistry. [\[Link\]](#)
- Various Authors. Gabriel Synthesis - Wikipedia. Wikipedia. [\[Link\]](#)
- CN112409237B - Preparation method of N-benzylphthalimide.
- Dadwal, A.; et al. Mitsunobu Reaction: A Powerful Tool for the Synthesis of Natural Products: A Review. National Institutes of Health. 2023. [\[Link\]](#)
- Various Authors. 2-methyl-2-phenyl-4-pentenal. Organic Syntheses Procedure. [\[Link\]](#)
- Barik, S.; et al. N-heterocyclic carbene-catalyzed atroposelective synthesis of N-Aryl phthalimides and maleimides via activation of carboxylic acids. PubMed Central. 2024. [\[Link\]](#)
- Still, W. C.; Kahn, M.; Mitra, A. Rapid chromatographic technique for preparative separations with moderate resolution. J. Org. Chem. 1978, 43(14), 2923–2925. [\[Link\]](#)
- Evans, D. A.; et al. Asymmetric Alkylation Reactions of Chiral Imide Enolates. A Practical Approach to the Enantioselective Synthesis of α -Substituted Carboxylic Acid Derivatives. J. Am. Chem. Soc. 1982, 104(6), 1737-1739. [\[Link\]](#)
- Various Authors. Purification of Organic Compounds by Flash Column Chromatography. JoVE. 2025. [\[Link\]](#)
- Various Authors. Mitsunobu Reaction - Wikipedia. Wikipedia. [\[Link\]](#)
- Le, Z.-G.; Chen, Z.-C.; Hu, Y.; Zheng, Q.-G. Organic Reactions in Ionic liquids: N-Alkylation of Phthalimide and Several Nitrogen Heterocycles. Synthesis. 2004, 208-212. [\[Link\]](#)
- Various Authors. Phthalimides: developments in synthesis and functionalization. RSC Publishing. 2024. [\[Link\]](#)
- Various Authors. Mitsunobu Reaction. Master Organic Chemistry. 2024. [\[Link\]](#)
- Various Authors. Mitsunobu Reaction. Chemistry Steps. [\[Link\]](#)

- Various Authors. Diastereoselective alkylation and methods for chiral auxiliary removal. ResearchGate. [\[Link\]](#)
- Various Authors. Acylation, Diastereoselective Alkylation, and Cleavage of an Oxazolidinone Chiral Auxiliary. Williams College Chemistry. [\[Link\]](#)
- Various Authors. The Mitsunobu Reaction. ResearchGate. [\[Link\]](#)
- Various Authors. Purification of Organic Compounds: from Crude Product to Purity. EMU Physics Department. [\[Link\]](#)
- Various Authors. Phthalimide-based π -Conjugated Small Molecules with Tailored Electronic Energy Levels for use as Acceptors in Organic Solar Cells. The Royal Society of Chemistry. [\[Link\]](#)
- Various Authors. Solubility determination and modelling for phthalimide in mixed solvents. ResearchGate. [\[Link\]](#)
- Various Authors. ChemInform Abstract: N-Alkylation of Imides Using Phase Transfer Catalysts under Solvent-Free Conditions. ResearchGate. [\[Link\]](#)
- Various Authors. Sustainable and Safe N-alkylation of N-heterocycles by Propylene Carbonate under Neat Reaction Conditions. MDPI. 2024. [\[Link\]](#)
- Various Authors. Decarboxylative Intramolecular Arene Alkylation Using N-(Acyloxy)phthalimides, an Organic Photocatalyst, and Visible Light. ACS Publications. 2019. [\[Link\]](#)

Need Custom Synthesis?

BenchChem offers custom synthesis for rare earth carbides and specific isotopic labeling.

Email: info@benchchem.com or [Request Quote Online](#).

Sources

- 1. masterorganicchemistry.com [masterorganicchemistry.com]

- [2. An exceptionally mild deprotection of phthalimides \[organic-chemistry.org\]](#)
- [3. Phthalimides \[organic-chemistry.org\]](#)
- [4. Reaction of Phthalimide: Deprotection and Amino Groups_Chemicalbook \[chemicalbook.com\]](#)
- [5. N-heterocyclic carbene-catalyzed atroposelective synthesis of N-Aryl phthalimides and maleimides via activation of carboxylic acids - PMC \[pmc.ncbi.nlm.nih.gov\]](#)
- [6. Mitsunobu Reaction: A Powerful Tool for the Synthesis of Natural Products: A Review - PMC \[pmc.ncbi.nlm.nih.gov\]](#)
- [7. organic-synthesis.com \[organic-synthesis.com\]](#)
- [8. rsc.org \[rsc.org\]](#)
- [9. CN112409237B - Preparation method of N-benzylphthalimide - Google Patents \[patents.google.com\]](#)
- [10. orgsyn.org \[orgsyn.org\]](#)
- [11. trilinkbiotech.com \[trilinkbiotech.com\]](#)
- To cite this document: BenchChem. [Technical Support Center: Synthesis of Asymmetric N-Substituted Phthalimides]. BenchChem, [2026]. [Online PDF]. Available at: [\[https://www.benchchem.com/product/b175618/docs#technical-support-center-synthesis-of-asymmetric-n-substituted-phthalimides\]](https://www.benchchem.com/product/b175618/docs#technical-support-center-synthesis-of-asymmetric-n-substituted-phthalimides)

Disclaimer & Data Validity:

The information provided in this document is for Research Use Only (RUO) and is strictly not intended for diagnostic or therapeutic procedures. While BenchChem strives to provide accurate protocols, we make no warranties, express or implied, regarding the fitness of this product for every specific experimental setup.

Technical Support: The protocols provided are for reference purposes. Unsure if this reagent suits your experiment?

Need Industrial/Bulk Grade? [Request Custom Synthesis Quote](#)

BenchChem

Our mission is to be the trusted global source of essential and advanced chemicals, empowering scientists and researchers to drive progress in science and industry.

Contact

Address: 3281 E Guasti Rd

Ontario, CA 91761, United States

Phone: (601) 213-4426

Email: info@benchchem.com

[Contact our Ph.D. Support Team for a compatibility check](#)