

# Technical Support Center: Preventing Racemization of Chiral Lactones

**Author:** BenchChem Technical Support Team. **Date:** May 2026

## Compound of Interest

Compound Name: (R)-4-Vinyldihydrofuran-2(3H)-one

CAS No.: 121959-61-3

Cat. No.: B175943

[Get Quote](#)

Welcome to the technical support center for chiral lactone stability. This guide is designed for researchers, chemists, and drug development professionals who work with stereochemically pure lactones. Chiral lactones are vital structural motifs in countless natural products and pharmaceuticals, where stereochemistry is often the primary determinant of biological activity. [1] The loss of enantiomeric purity through racemization can lead to diminished efficacy, altered pharmacological profiles, and complex purification challenges.

This resource provides in-depth troubleshooting guides and frequently asked questions to help you diagnose, prevent, and resolve issues of racemization in your experimental workflows.

## Understanding the Core Problem: The Mechanism of Racemization

Before troubleshooting, it's crucial to understand why racemization occurs. For lactones with a stereocenter at the alpha-position (the carbon adjacent to the carbonyl group), the primary mechanism of racemization is the formation of a planar, achiral intermediate.[2] This process is readily catalyzed by both acids and bases.[3]

- **Base-Catalyzed Racemization:** A base removes the acidic proton from the  $\alpha$ -carbon, creating a planar, resonance-stabilized enolate anion. Reprotonation of this flat intermediate can occur from either face with equal probability, leading to a 50:50 mixture of the original enantiomer and its mirror image (a racemic mixture).[3][4]
- **Acid-Catalyzed Racemization:** An acid protonates the carbonyl oxygen, making the  $\alpha$ -proton more acidic. A weak base (such as water or an alcohol solvent) can then remove the  $\alpha$ -proton to form a planar enol. Tautomerization back to the keto form can proceed via protonation from either face, again resulting in racemization.[3][5]

The following diagram illustrates this fundamental process.

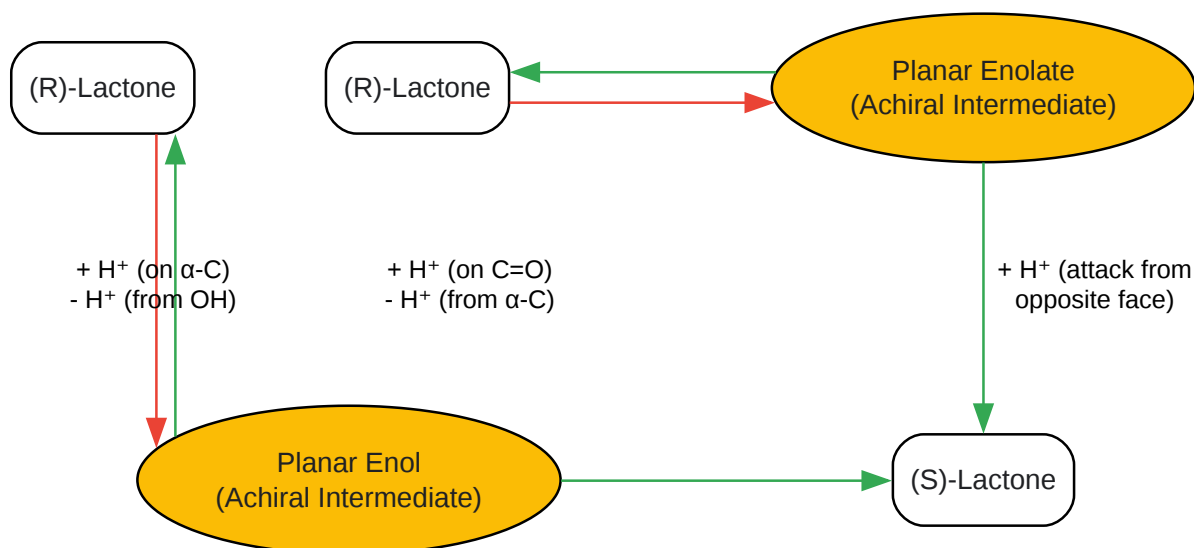

[Click to download full resolution via product page](#)

Caption: Mechanism of acid- and base-catalyzed racemization via planar intermediates.

## Troubleshooting Guide: Experimental Scenarios

This section addresses specific problems you may encounter during your work.

**Q1:** My chiral lactone is racemizing during a base-catalyzed reaction. Why is this happening and how can I fix it?

Plausible Cause: This is the most common racemization scenario. The base used in your reaction is abstracting the proton at the chiral  $\alpha$ -carbon, leading to the formation of a planar enolate intermediate.<sup>[3][4]</sup> It's important to recognize that even relatively weak bases, such as tertiary amines (e.g., triethylamine) or basic byproducts from coupling reagents, can be sufficient to cause racemization, especially with prolonged reaction times or elevated temperatures.<sup>[4]</sup>

#### Solutions & Preventative Measures:

- Reagent Selection:
  - Use a Weaker Base: If possible, switch to a milder base (e.g., DIPEA instead of DBU) or a non-nucleophilic, sterically hindered base that is less likely to deprotonate the  $\alpha$ -carbon.
  - Avoid Excess Base: Use the minimum stoichiometric amount of base required for the reaction.
- Reaction Conditions:
  - Lower the Temperature: Perform the reaction at the lowest possible temperature that allows for a reasonable reaction rate. Cryogenic temperatures (-78 °C) are often effective.
  - Reduce Reaction Time: Monitor the reaction closely (e.g., by TLC or LC-MS) and quench it as soon as the starting material is consumed to minimize the lactone's exposure to basic conditions.
  - Solvent Choice: Use aprotic, non-polar solvents (e.g., Toluene, Hexane) which can disfavor the formation and stabilization of the enolate intermediate.
- Alternative Synthetic Routes: Consider synthetic strategies that avoid basic conditions entirely, such as using enzymatic resolutions or acid-catalyzed cyclizations where applicable.<sup>[6][7]</sup>

Q2: I'm observing a loss of optical purity after purification by silica gel chromatography. What went wrong?

Plausible Cause: Standard silica gel is inherently acidic (surface pH  $\approx$  4-5) due to the presence of silanol groups. This acidic surface can act as a catalyst for enolization, leading to racemization directly on the column.[2] The large surface area and the time your compound spends on the column exacerbate this effect. Conversely, some grades of silica can contain basic impurities, which can also catalyze racemization.

Solutions & Preventative Measures:

- Neutralize the Silica Gel: Before preparing your column, deactivate the acidic sites.
  - Protocol for Silica Gel Neutralization:
    - Prepare a slurry of your silica gel in a non-polar solvent (e.g., hexanes).
    - Add 1-2% triethylamine ( $\text{Et}_3\text{N}$ ) by volume relative to the solvent.
    - Stir the slurry for 30-60 minutes.
    - Filter the silica gel and wash it thoroughly with the pure, non-polar solvent to remove excess amine.
    - Dry the neutralized silica gel under high vacuum before use.
- Buffer the Mobile Phase: Add a small amount of a neutral or slightly basic modifier, like triethylamine ( $\sim$ 0.1-0.5%), to your eluent system to continuously neutralize the column's acidic sites during the run.
- Use an Alternative Stationary Phase: Consider using neutral alumina or treated phases like Florisil.
- Minimize Contact Time: Use flash chromatography with higher pressure to push the compound through the column faster. Avoid letting the compound sit on the column for extended periods.
- Explore Non-Chromatographic Methods: If possible, purify your lactone by crystallization, distillation, or solvent extraction to avoid contact with solid supports altogether.[8][9]

### Q3: My lactone's enantiomeric excess is decreasing during workup and storage. How can I prevent this?

Plausible Cause: Racemization is not limited to reaction or purification steps. Trace amounts of acid or base in your workup solutions, or on the surface of glassware, can cause slow racemization over time.<sup>[10]</sup> Additionally, elevated temperatures and exposure to UV light can also contribute to degradation and loss of optical purity.<sup>[10]</sup> For example, D-panthenol is known to be most stable in a pH range of 4-6 and is susceptible to racemization at higher temperatures.<sup>[10]</sup>

#### Solutions & Preventative Measures:

- Neutral Workup: During aqueous extractions, ensure the pH of your aqueous layer is maintained near neutral (pH 7). Use buffered washes (e.g., phosphate-buffered saline) instead of strong acid or base washes if possible.
- Proper Glassware Preparation:
  - Protocol for Glassware Neutralization:
    - Wash glassware thoroughly with detergent and water.
    - Rinse with deionized water.
    - Perform an acid wash (e.g., soak in 1M HCl for 1-2 hours) to remove any basic residues.
    - Rinse thoroughly with deionized water until the rinsate is neutral.
    - Rinse with a solvent like acetone or ethanol and oven-dry or flame-dry under vacuum immediately before use to ensure it is anhydrous.
- Optimal Storage Conditions:
  - Temperature: Store the purified lactone at low temperatures, ideally at -20 °C or below.
  - Atmosphere: Store under an inert atmosphere (e.g., Argon or Nitrogen) to prevent oxidative degradation.

- Solvent: If storing in solution, use a dry, aprotic, and neutral solvent. For long-term storage, removing the solvent and storing the compound as a solid or oil is preferable.
- Light: Use amber-colored vials or wrap vials in aluminum foil to protect the compound from light.

## Decision-Making Workflow for Troubleshooting Racemization

When a loss of optical purity is detected, use the following workflow to systematically identify and address the source of the problem.

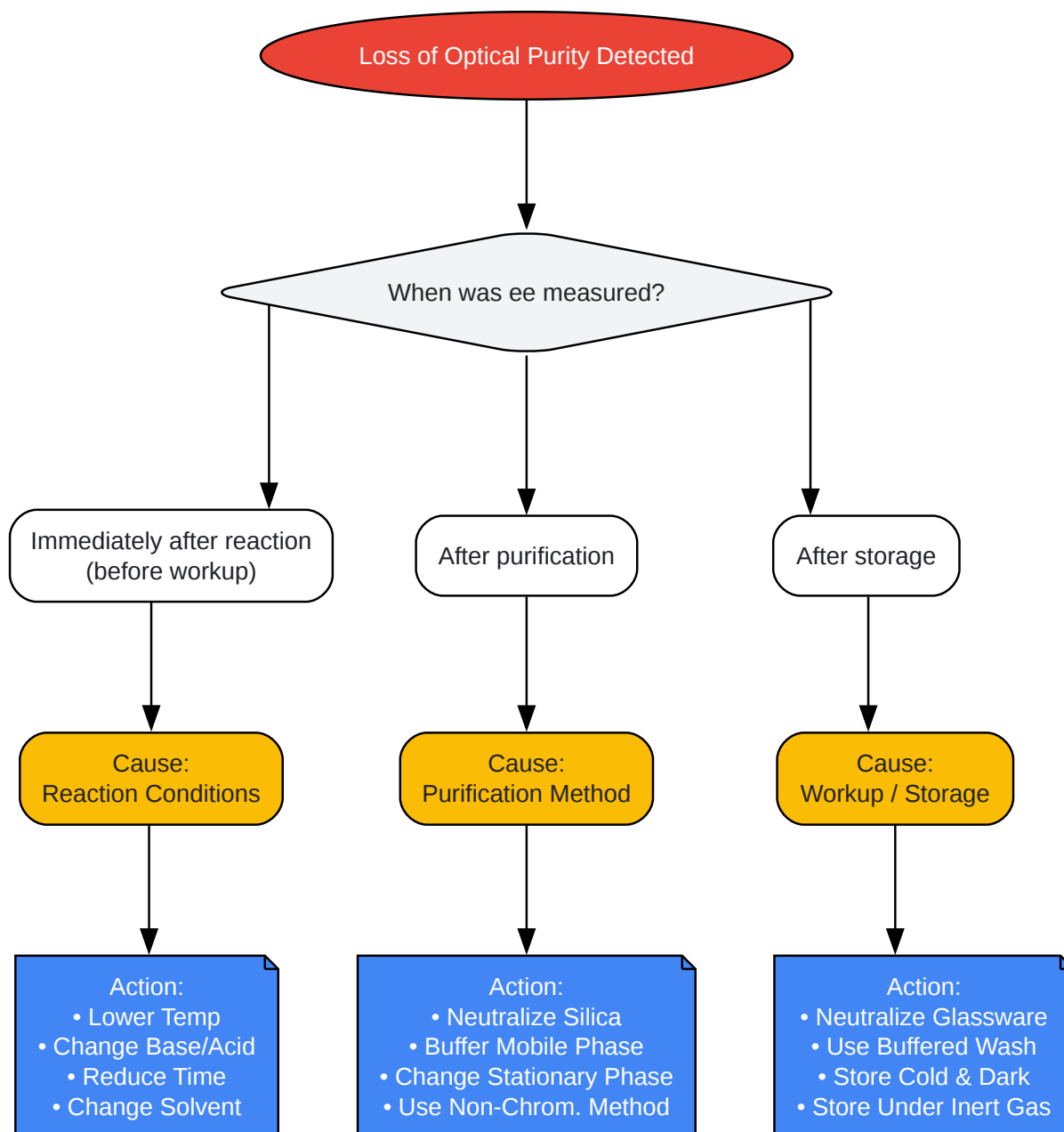

[Click to download full resolution via product page](#)

Caption: A workflow to diagnose the source of racemization in an experiment.

## Frequently Asked Questions (FAQs)

Q: How can I accurately measure the enantiomeric excess (ee) of my lactone? A: The most reliable and accurate methods are chromatographic. Chiral High-Performance Liquid

Chromatography (HPLC) and Gas Chromatography (GC) using chiral stationary phases are considered the gold standard for their high resolution and accuracy.[11] Nuclear Magnetic Resonance (NMR) spectroscopy using chiral shift reagents or chiral solvating agents is another powerful technique.[12][13] While traditional polarimetry is often used, its accuracy can be affected by sample concentration, solvent, temperature, and impurities.[13]

Q: Are certain lactones more prone to racemization than others? A: Yes. The primary factor is the presence of an acidic hydrogen on the chiral  $\alpha$ -carbon.[2][3] Lactones with electron-withdrawing groups at or near the  $\alpha$ -position will have a more acidic  $\alpha$ -proton and will thus be more susceptible to base-catalyzed racemization. The structural environment around the  $\alpha$ -proton (steric hindrance) can also play a role, with less hindered protons being more easily abstracted.

Q: Can I use coupling reagents like EDC or HATU without causing racemization? A: Caution is advised. While the primary function of these reagents is amide or ester formation, their use often involves basic additives (like HOBT, DIPEA, or NMM) which can promote racemization.[14][15] Some byproducts of these reagents can also be basic.[4] To minimize risk, use the lowest possible temperature, choose additives known to suppress racemization (e.g., HOBT), and limit the reaction time.[14]

Q: Does solvent choice significantly impact the rate of racemization? A: Absolutely. Polar, protic solvents (like water, methanol, ethanol) can facilitate racemization by stabilizing charged intermediates (enolates) and participating in proton transfer steps in both acid and base-catalyzed pathways. Aprotic, non-polar solvents (like toluene, hexanes, or diethyl ether) are generally preferred as they disfavor the formation of these intermediates.

## Summary of Factors Influencing Lactone Racemization

Factor	High Risk Conditions	Recommended Preventative Measures
pH	Strongly acidic (pH < 3) or basic (pH > 8) conditions.[5][10][16]	Maintain pH as close to neutral as possible (ideally pH 4-7). Use buffers during workup.[10]
Temperature	Elevated temperatures (> 40 °C); prolonged heating.[10]	Perform reactions at low temperatures (-78 °C to 0 °C). Store samples at -20 °C or below.
Catalysts	Strong acids, strong bases, certain metal catalysts.	Use mild, non-nucleophilic bases; weak acid catalysts; or enzymatic methods.[6][17]
Solvent	Polar, protic solvents (e.g., H <sub>2</sub> O, MeOH, EtOH).	Use aprotic, non-polar solvents (e.g., Toluene, Hexane, CH <sub>2</sub> Cl <sub>2</sub> ).
Purification	Standard silica gel chromatography.[2]	Use neutralized silica, neutral alumina, or non-chromatographic methods like crystallization.[8]
Exposure Time	Long reaction times; extended storage in solution.	Monitor reactions closely and minimize duration. Store as a solid under an inert atmosphere.

## References

- A Comparative Guide to Assessing the Enantiomeric Excess of Chiral Bicyclic Lactones. (2025). Benchchem.
- Theoretical Study on the Epimerization of Azlactone Rings: Keto–Enol Tautomerism or Base-Mediated Racemiz
- Jakovac, I. J., & Jones, J. B. (1978). General Method for Determining Enantiomeric Purities of Chiral Lactones. RSC Publishing.
- Methods to prevent racemization of D-panthenol during chemical synthesis. (2025). Benchchem.

- CHEM 2325 Module 27: Alpha Substitution Reactions - Racemiz
- Yasa, H., & Yusufoglu, S. (2018). Synthesis of New Medium- and Large- Sized Racemic and Chiral Lactones. Journal of the Turkish Chemical Society, Section A: Chemistry.
- Biocatalytic synthesis of lactones and lactams. (2016). Catalysis Science & Technology via PMC - NIH.
- Orozco, M., et al. (2013). Mechanisms of lactone hydrolysis in neutral and alkaline conditions. The Journal of Organic Chemistry via PubMed.
- Determination of enantiomeric excess. (n.d.).
- A Head-to-Head Comparison of Purification Techniques for Beta-Lactones. (2025). Benchchem.
- Lactone synthesis. (n.d.). Organic Chemistry Portal.
- Aggregation, Racemization and Side Reactions in Peptide Synthesis. (n.d.). AAPPTEC.
- Chemoenzymatic Synthesis of trans- $\beta$ -Aryl- $\delta$ -hydroxy- $\gamma$ -lactones and Enzymatic Kinetic Resolution of Their Racemic Mixtures. (2018). MDPI.
- Orozco, M., et al. (2013). Mechanisms of lactone hydrolysis in acidic conditions. The Journal of Organic Chemistry.
- Roberts, J. D., et al. (2021).
- Purification method of lactone compounds containing unsaturated alkyl group by extraction with silver ion solution. (2012).
- Suppression of alpha-carbon racemization in peptide synthesis based on a thiol-labile amino protecting group. (2023).

### Need Custom Synthesis?

BenchChem offers custom synthesis for rare earth carbides and specific isotopic labeling.

Email: [info@benchchem.com](mailto:info@benchchem.com) or [Request Quote Online](#).

## Sources

- [1. pdfs.semanticscholar.org](https://pdfs.semanticscholar.org) [[pdfs.semanticscholar.org](https://pdfs.semanticscholar.org)]
- [2. chem.libretexts.org](https://chem.libretexts.org) [[chem.libretexts.org](https://chem.libretexts.org)]
- [3. youtube.com](https://youtube.com) [[youtube.com](https://youtube.com)]
- [4. Theoretical Study on the Epimerization of Azlactone Rings: Keto–Enol Tautomerism or Base-Mediated Racemization? - PMC](#) [[pmc.ncbi.nlm.nih.gov](https://pubmed.ncbi.nlm.nih.gov)]
- [5. researchportal.hw.ac.uk](https://researchportal.hw.ac.uk) [[researchportal.hw.ac.uk](https://researchportal.hw.ac.uk)]

- [6. Biocatalytic synthesis of lactones and lactams - PMC \[pmc.ncbi.nlm.nih.gov\]](#)
- [7. Lactone synthesis \[organic-chemistry.org\]](#)
- [8. pdf.benchchem.com \[pdf.benchchem.com\]](#)
- [9. JP2785363B2 - Lactone purification method - Google Patents \[patents.google.com\]](#)
- [10. pdf.benchchem.com \[pdf.benchchem.com\]](#)
- [11. pdf.benchchem.com \[pdf.benchchem.com\]](#)
- [12. General method for determining enantiomeric purities of chiral lactones - Journal of the Chemical Society, Chemical Communications \(RSC Publishing\) \[pubs.rsc.org\]](#)
- [13. Determination of enantiomeric excess \[ch.ic.ac.uk\]](#)
- [14. peptide.com \[peptide.com\]](#)
- [15. Suppression of alpha-carbon racemization in peptide synthesis based on a thiol-labile amino protecting group - PMC \[pmc.ncbi.nlm.nih.gov\]](#)
- [16. Mechanisms of lactone hydrolysis in neutral and alkaline conditions - PubMed \[pubmed.ncbi.nlm.nih.gov\]](#)
- [17. mdpi.com \[mdpi.com\]](#)
- To cite this document: BenchChem. [Technical Support Center: Preventing Racemization of Chiral Lactones]. BenchChem, [2026]. [Online PDF]. Available at: [\[https://www.benchchem.com/product/b175943/docs#technical-support-center-preventing-racemization-of-chiral-lactones\]](https://www.benchchem.com/product/b175943/docs#technical-support-center-preventing-racemization-of-chiral-lactones)

---

### Disclaimer & Data Validity:

The information provided in this document is for Research Use Only (RUO) and is strictly not intended for diagnostic or therapeutic procedures. While BenchChem strives to provide accurate protocols, we make no warranties, express or implied, regarding the fitness of this product for every specific experimental setup.

**Technical Support:** The protocols provided are for reference purposes. Unsure if this reagent suits your experiment?

**Need Industrial/Bulk Grade?** [Request Custom Synthesis Quote](#)

# BenchChem

Our mission is to be the trusted global source of essential and advanced chemicals, empowering scientists and researchers to drive progress in science and industry.

## Contact

Address: 3281 E Guasti Rd

Ontario, CA 91761, United States

Phone: (601) 213-4426

Email: [info@benchchem.com](mailto:info@benchchem.com)

[Contact our Ph.D. Support Team for a compatibility check](#)