

# Application Note: Optimized Synthesis of 4-Chloro-2-(methylsulfonamido)benzoic acid

**Author:** BenchChem Technical Support Team. **Date:** May 2026

## Compound of Interest

Compound Name:	4-Chloro-2-(methylsulfonamido)benzoic acid
CAS No.:	158579-89-6
Cat. No.:	B175868

[Get Quote](#)

## Introduction & Scope

This application note details the synthesis of **4-Chloro-2-(methylsulfonamido)benzoic acid** (CAS: 158579-89-6), a critical pharmacophore in the development of EP3 receptor antagonists, anti-viral agents, and anti-inflammatory scaffolds.

While conceptually simple, the sulfonylation of anthranilic acid derivatives presents specific chemoselective challenges. The primary difficulty lies in the competition between N-sulfonylation (desired) and O-sulfonylation (mixed anhydride formation), as well as the potential for bis-mesylation of the aniline nitrogen.

This guide provides two validated protocols:

- Protocol A (The Precision Route): A 3-step protection-deprotection strategy yielding the highest purity (>98%), recommended for GMP or late-stage discovery.
- Protocol B (The Direct Route): A scalable, 1-step Schotten-Baumann procedure suitable for rapid scale-up of early intermediates.

## Retrosynthetic Strategy & Logic

The synthesis is designed to control the nucleophilicity of the aniline nitrogen while protecting the carboxylic acid from activation.

### Strategic Analysis

- The Challenge: Reacting methanesulfonyl chloride (MsCl) directly with the free amino acid (2-amino-4-chlorobenzoic acid) in organic base (e.g., TEA/DCM) often leads to the formation of a mixed carboxylic-sulfonic anhydride. This unstable intermediate can cyclize or hydrolyze unpredictably, lowering yields.
- The Solution:
  - Route A masks the carboxylic acid as a methyl ester, forcing the MsCl to react exclusively with the amine.
  - Route B uses aqueous conditions where the high dielectric constant and the presence of water rapidly hydrolyze any transient O-sulfonated species back to the carboxylate, leaving the stable N-sulfonamide intact.

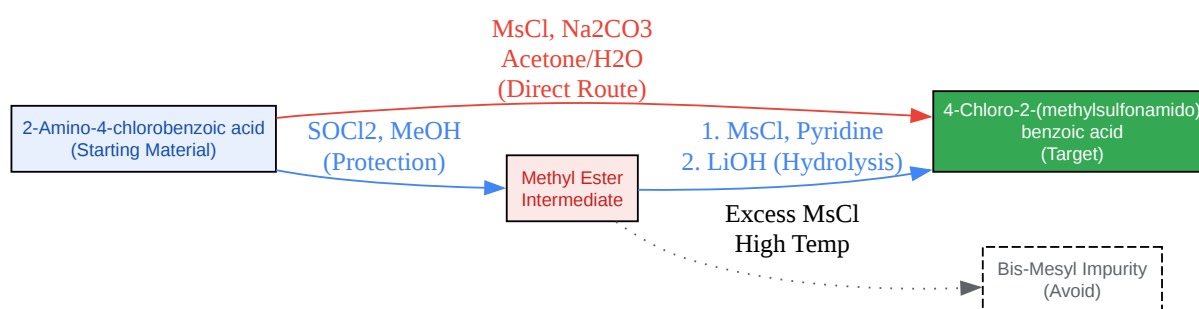

[Click to download full resolution via product page](#)

Figure 1: Strategic pathways for N-mesylation. The Blue path (Protection) offers higher purity control; the Red path (Direct) offers speed.

## Protocol A: The Precision Route (Recommended)

Objective: Synthesis of high-purity target via Methyl 2-amino-4-chlorobenzoate.

## Step 1: Esterification

Reaction: 2-Amino-4-chlorobenzoic acid

Methyl 2-amino-4-chlorobenzoate.

- Setup: Charge a 250 mL round-bottom flask (RBF) with 2-Amino-4-chlorobenzoic acid (10.0 g, 58.3 mmol) and Methanol (anhydrous, 100 mL).
- Activation: Cool to 0°C. Dropwise add Thionyl Chloride (SOCl<sub>2</sub>), 8.5 mL, 116 mmol) over 20 mins. Caution: Exothermic/Gas evolution.
- Reflux: Heat to reflux (65°C) for 4 hours. Monitor by TLC (30% EtOAc/Hexane).
- Workup: Concentrate in vacuo. Resuspend residue in EtOAc (150 mL), wash with sat. NaHCO<sub>3</sub> (2 x 50 mL) and Brine. Dry over Na<sub>2</sub>SO<sub>4</sub>, filter, and concentrate.
  - Yield Expectation: ~90-95% (Off-white solid).

## Step 2: N-Mesylation

Reaction: Methyl 2-amino-4-chlorobenzoate

Methyl 4-chloro-2-(methylsulfonamido)benzoate.

- Solvation: Dissolve the ester (10.0 g, ~54 mmol) in Dichloromethane (DCM) (100 mL) and Pyridine (13 mL, 162 mmol).
- Addition: Cool to 0°C. Add Methanesulfonyl chloride (MsCl) (4.6 mL, 59 mmol) dropwise.
  - Critical Control Point: Maintain T < 5°C to prevent bis-mesylation.

- Reaction: Stir at 0°C for 1 hour, then warm to RT overnight.
- Quench: Add 1M HCl (50 mL) to remove Pyridine. Separate organic layer.[1][2]
- Purification: If bis-mesylated impurity is visible by TLC (less polar spot), recrystallize from EtOH.
  - Note: Bis-mesyl species can often be hydrolyzed to mono-mesyl in the next step, so minor contamination is acceptable.

### Step 3: Hydrolysis to Target

Reaction: Methyl ester cleavage.

- Hydrolysis: Dissolve intermediate in THF (50 mL) and Water (50 mL). Add LiOH·H<sub>2</sub>O (6.8 g, 162 mmol).
- Stir: Stir at RT for 4–6 hours.
- Isolation:
  - Concentrate to remove THF.
  - Acidify aqueous residue with 1M HCl to pH ~2.
  - The product will precipitate as a white solid.
- Filtration: Filter, wash with cold water, and dry under vacuum at 45°C.

### Protocol B: The Direct Route (Schotten-Baumann)

Objective: Rapid synthesis using aqueous media. Best for scale-up when chromatography is not desired.

Reagents:

- 2-Amino-4-chlorobenzoic acid (5.0 g, 29.1 mmol)

- Sodium Carbonate (Na  
CO  
) (7.7 g, 72.8 mmol)
- Methanesulfonyl chloride (MsCl) (2.5 mL, 32.0 mmol)
- Solvent: Water (40 mL) / Acetone (10 mL)

#### Procedure:

- Dissolution: In a 250 mL beaker, dissolve the amino acid and Na  
CO  
in Water/Acetone mixture. The solution should be clear and basic (pH > 10).
- Cooling: Chill to 0–5°C in an ice bath.
- Addition: Add MsCl dropwise over 30 minutes with vigorous stirring.
  - Why: MsCl hydrolyzes in water. Slow addition at low temp favors the reaction with the amine over water.
- Monitoring: Stir at RT for 3 hours. If starting material remains (TLC), re-cool to 0°C and add 0.2 eq of MsCl and adjust pH back to >9 with carbonate.
- Workup:
  - Carefully acidify with conc. HCl to pH 1–2.
  - The product precipitates.[\[1\]](#)[\[3\]](#)[\[4\]](#)
  - Filter and wash with excess water to remove salts and sulfonic acid byproducts.
- Recrystallization: Recrystallize from Ethanol/Water (8:2) if the melting point is broad.

## Analytical Validation & Specifications

Parameter	Specification	Method
Appearance	White to off-white crystalline solid	Visual
Purity	> 97.0%	HPLC (C18, ACN/Water + 0.1% TFA)
1H NMR (DMSO-d6)	3.15 (s, 3H, SO CH ) , 7.2 (dd, 1H), 7.6 (d, 1H), 7.9 (d, 1H), 11.0 (s, 1H, NH), 13.5 (br, COOH)	400 MHz NMR
Mass Spec	[M-H] <sup>-</sup> = 248.0	ESI-MS (Negative Mode)
Melting Point	228–232°C (Decomposes)	Capillary Method

## Troubleshooting & Optimization

### Decision Logic for Impurities

Use the following logic flow to address common synthesis issues.

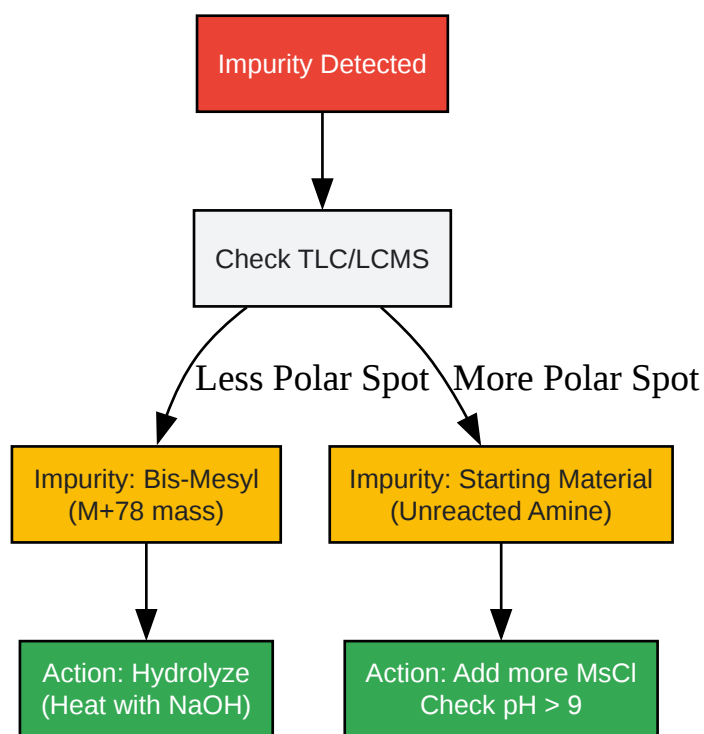

[Click to download full resolution via product page](#)

Figure 2: Troubleshooting logic for common reaction failures.

## Critical Notes

- Bis-mesylation: If you observe a product with Mass = 327 (M+H of bis-mesyl), do not discard. Treat the crude mixture with 2M NaOH at 60°C for 1 hour. The second sulfonyl group on the nitrogen is labile and will hydrolyze, reverting to the desired mono-sulfonamide.
- Solubility: The target molecule is sparingly soluble in water at acidic pH but highly soluble at pH > 7. Ensure pH < 2 during precipitation to maximize yield.

## References

- General Sulfonamide Synthesis: "Synthesis of Sulfonamides Using 4-(Chlorosulfonyl)benzoic Acid." BenchChem Application Notes. [Link](#) (Accessed 2023).
- N-Mesylation Methodology: Mao, L., et al.[5] "A Convenient Synthesis of Amino Acid Arylamides Utilizing Methanesulfonyl Chloride." Synlett, 2011, 129-133.[5] [Link](#)

- Anthranilic Acid Derivatives: "Preparation of N-Aryl Anthranilic Acid Drugs." ResearchGate. [Link](#)
- Chemical Properties: "4-Chloro-2-(methylsulfonamido)benzoic acid Product Page." Sigma-Aldrich. [Link](#)
- Analogous Synthesis (Sulfones): "Synthesis of 2-chloro-4-(methylsulfonyl)benzoic acid." PrepChem. [Link](#)

#### Need Custom Synthesis?

BenchChem offers custom synthesis for rare earth carbides and specific isotopic labeling.

Email: [info@benchchem.com](mailto:info@benchchem.com) or [Request Quote Online](#).

## Sources

- [1. prepchem.com \[prepchem.com\]](https://www.prepchem.com)
- [2. Organic Syntheses Procedure \[orgsyn.org\]](https://www.orgsyn.org)
- [3. Organic Syntheses Procedure \[orgsyn.org\]](https://www.orgsyn.org)
- [4. pdf.benchchem.com \[pdf.benchchem.com\]](https://www.pdf.benchchem.com)
- [5. A Convenient Synthesis of Amino Acid Arylamides Utilizing Methanesulfonyl Chloride and N-Methylimidazole \[organic-chemistry.org\]](#)
- To cite this document: BenchChem. [Application Note: Optimized Synthesis of 4-Chloro-2-(methylsulfonamido)benzoic acid]. BenchChem, [2026]. [Online PDF]. Available at: [\[https://www.benchchem.com/product/b175868/docs#application-note-optimized-synthesis-of-4-chloro-2-methylsulfonamido-benzoic-acid\]](https://www.benchchem.com/product/b175868/docs#application-note-optimized-synthesis-of-4-chloro-2-methylsulfonamido-benzoic-acid)

### Disclaimer & Data Validity:

The information provided in this document is for Research Use Only (RUO) and is strictly not intended for diagnostic or therapeutic procedures. While BenchChem strives to provide accurate protocols, we make no warranties, express or implied, regarding the fitness of this product for every specific experimental setup.

**Technical Support:** The protocols provided are for reference purposes. Unsure if this reagent suits your experiment?

**Need Industrial/Bulk Grade?** [Request Custom Synthesis Quote](#)

## BenchChem

Our mission is to be the trusted global source of essential and advanced chemicals, empowering scientists and researchers to drive progress in science and industry.

### Contact

Address: 3281 E Guasti Rd  
Ontario, CA 91761, United States  
Phone: (601) 213-4426  
Email: [info@benchchem.com](mailto:info@benchchem.com)

[Contact our Ph.D. Support Team for a compatibility check](#)