

# Technical Support Center: Troubleshooting Signal Integrity with Diphenylborinate Compounds

**Author:** BenchChem Technical Support Team. **Date:** May 2026

## Compound of Interest

Compound Name: Glycyl diphenylborinate

CAS No.: 14335-29-6

Cat. No.: B174338

[Get Quote](#)

A Note on Nomenclature: While the query specified "**glycyl diphenylborinate**," this compound is not widely documented in scientific literature. It is highly probable that the intended compound is 2-Aminoethyl diphenylborinate (2-APB), a structurally similar and extensively studied modulator of intracellular signaling. This guide will focus on 2-APB, with the understanding that the principles of troubleshooting weak or no signal will be broadly applicable to other diphenylborinate-based probes.

## Introduction to 2-Aminoethyl Diphenylborinate (2-APB)

2-Aminoethyl diphenylborinate (2-APB) is a membrane-permeable compound widely utilized in cell biology and pharmacology research.[1][2] It is best known as a modulator of store-operated calcium entry (SOCE), a crucial mechanism for replenishing intracellular calcium stores and mediating a variety of cellular processes.[3][4][5] The intricate function of 2-APB is dose-dependent, acting as a potentiator of SOCE at low concentrations ( $\leq 10 \mu\text{M}$ ) and an inhibitor at higher concentrations ( $\geq 30 \mu\text{M}$ ).[3][5] This bimodal activity, along with its effects on other

targets like IP3 receptors and TRP channels, makes precise experimental control paramount.

[1][3][5]

This guide is designed to serve as a primary resource for researchers encountering issues of weak or no signal during experiments involving 2-APB. As Senior Application Scientists, we have compiled field-proven insights and evidence-based protocols to help you diagnose and resolve these common challenges.

## Frequently Asked Questions (FAQs)

Q1: What is the primary mechanism of action for 2-APB?

A1: 2-APB's most well-characterized role is the modulation of store-operated calcium entry (SOCE).[3][4] SOCE is a process triggered by the depletion of calcium from the endoplasmic reticulum (ER), which then activates STIM proteins in the ER membrane. These STIM proteins translocate to the plasma membrane to interact with and open Orai channels, allowing for the influx of extracellular calcium.[3][5] 2-APB can both enhance or block this process depending on its concentration, and has also been shown to inhibit IP3 receptors, further impacting intracellular calcium dynamics.[3][5]

Q2: How should I prepare and store 2-APB solutions?

A2: 2-APB is typically supplied as a powder and should be stored at -20°C.[1] For experimental use, prepare a concentrated stock solution (e.g., 10-100 mM) in a high-quality, anhydrous solvent such as DMSO or ethanol. Aliquot the stock solution into single-use volumes to avoid repeated freeze-thaw cycles, which can lead to degradation. Store these aliquots at -20°C, protected from light and moisture.[6] When preparing working solutions, dilute the stock solution in your aqueous experimental buffer immediately before use.

Q3: What are the optimal excitation and emission wavelengths for detecting signals in experiments with 2-APB?

A3: 2-APB itself is not a fluorescent probe. It is a modulator of cellular processes, most commonly calcium signaling. Therefore, the signal you are detecting comes from a fluorescent indicator dye used in conjunction with 2-APB, such as a calcium indicator (e.g., Fura-2, Fluo-4, or genetically encoded indicators like GCaMP).[7][8][9] The excitation and emission wavelengths will be specific to the chosen indicator dye. Always consult the manufacturer's

specifications for your fluorescent probe to determine the optimal settings for your microscope or plate reader.

Q4: Can 2-APB be used in live-cell imaging?

A4: Yes, 2-APB is membrane-permeable and widely used in live-cell imaging experiments to study dynamic processes like calcium signaling in real-time.<sup>[7][10][11]</sup>

## Troubleshooting Guide: Weak or No Signal

A weak or absent signal in experiments involving 2-APB can be frustrating. The following guide provides a systematic approach to identifying and resolving the root cause of the issue.

### Problem Area 1: Reagent and Preparation

Q: I've added 2-APB to my cells, but I'm not observing the expected change in my fluorescent signal. Could the compound itself be the problem?

A: Yes, issues with the 2-APB solution are a common culprit. Here's how to troubleshoot:

- **Causality:** The chemical integrity and concentration of your 2-APB solution are critical. Degradation or inaccurate concentration can lead to a complete loss of effect or an unintended bimodal response (e.g., potentiation instead of inhibition).
- **Troubleshooting Steps:**
  - **Verify Stock Solution Integrity:** Prepare a fresh stock solution of 2-APB from the powder. If you suspect your solvent (DMSO/ethanol) has absorbed water, use a fresh, unopened bottle.
  - **Confirm Working Concentration:** Double-check your dilution calculations. Given 2-APB's bimodal nature, an error in dilution could shift its effect from inhibitory to potentiating, or vice-versa, leading to confusing results.<sup>[3]</sup>
  - **Perform a Concentration-Response Curve:** If the issue persists, run a concentration-response experiment to determine the optimal concentration for your specific cell type and experimental conditions. This is a crucial step for validating a new batch of 2-APB or when establishing a new experimental model.

Parameter	Recommendation	Rationale
Stock Solvent	Anhydrous DMSO or Ethanol	Prevents hydrolysis of 2-APB.
Stock Storage	-20°C, protected from light, in small aliquots	Minimizes degradation from freeze-thaw cycles and light exposure.[1]
Working Solution	Prepare fresh for each experiment	Ensures accurate final concentration and avoids degradation in aqueous buffer.

## Problem Area 2: Experimental Protocol and Conditions

Q: My reagents seem fine, but I'm still getting a weak or no signal. What in my protocol could be wrong?

A: The experimental design, particularly the timing and composition of your buffers, can significantly impact signal detection.

- Causality: The kinetics of cellular responses to 2-APB and the chemical environment of the experiment are critical. Inadequate incubation times, interfering buffer components, or suboptimal detection methods can all lead to signal loss.
- Troubleshooting Steps:
  - Optimize Incubation Time: The time required for 2-APB to exert its effect can vary between cell types. Perform a time-course experiment to identify the optimal pre-incubation time before initiating your measurement.
  - Evaluate Your Buffer Composition: Certain buffer components can interact with reagents used for signal detection. For example, some organic buffers can interfere with reactive oxygen species (ROS) assays.[12] Ensure your buffer is compatible with your entire experimental system.
  - Check Your Positive and Negative Controls:

- **Positive Control:** Use a known agonist for your system (e.g., thapsigargin to induce store depletion for SOCE studies) to confirm that the cells are responsive and your detection system is working correctly.[3][5]
- **Negative Control:** A vehicle control (e.g., buffer with the same concentration of DMSO used for the 2-APB solution) is essential to ensure that the solvent itself is not causing an effect.
- **Review Detector Settings:** For fluorescence-based assays, ensure that your microscope or plate reader settings (e.g., excitation/emission wavelengths, gain, exposure time) are optimized for your specific fluorophore.[13][14]

## Problem Area 3: Cell Health and Viability

Q: Could the state of my cells be the reason for the weak signal?

A: Absolutely. Healthy, responsive cells are the foundation of a successful experiment.

- **Causality:** Stressed or unhealthy cells will not exhibit robust physiological responses. Factors like passage number, confluency, and overall viability can drastically alter their signaling capacity.
- **Troubleshooting Steps:**
  - **Assess Cell Viability:** Use a viability stain (e.g., Trypan Blue or a live/dead fluorescence assay) to confirm that your cell population is healthy (>95% viability) before starting the experiment.
  - **Control for Confluency:** Cell confluency can impact signaling. Highly confluent cells may exhibit contact inhibition, while very sparse cultures may not provide a strong enough signal. Standardize the seeding density and confluency for all experiments.
  - **Use Low Passage Number Cells:** Cells at high passage numbers can undergo phenotypic changes, including alterations in receptor and channel expression. Use cells within a consistent and low passage number range.
  - **Ensure Expression of Target Receptors/Channels:** The effect of 2-APB is dependent on the presence and functional state of its targets (e.g., Orai, STIM, IP3R). If you are working

with a new cell line, you may need to confirm the expression of these key components via methods like qPCR or Western blotting.

## Visualized Workflows and Mechanisms

### Mechanism of Store-Operated Calcium Entry (SOCE) and 2-APB Intervention

The following diagram illustrates the SOCE pathway and the key points where 2-APB exerts its modulatory effects.

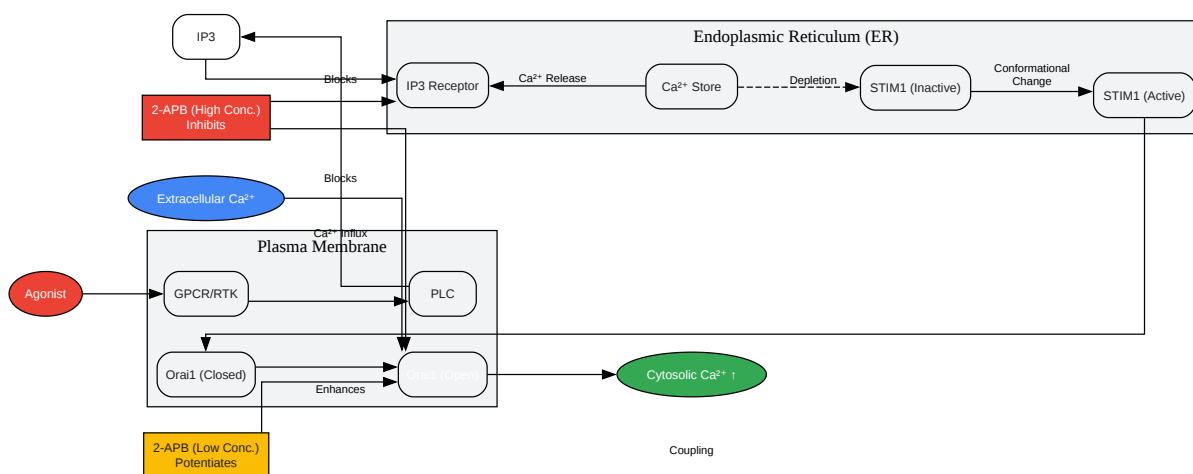

[Click to download full resolution via product page](#)

Caption: Mechanism of SOCE and modulation by 2-APB.

## Troubleshooting Workflow for Weak or No Signal

This flowchart provides a logical sequence of steps to diagnose the source of signal issues.

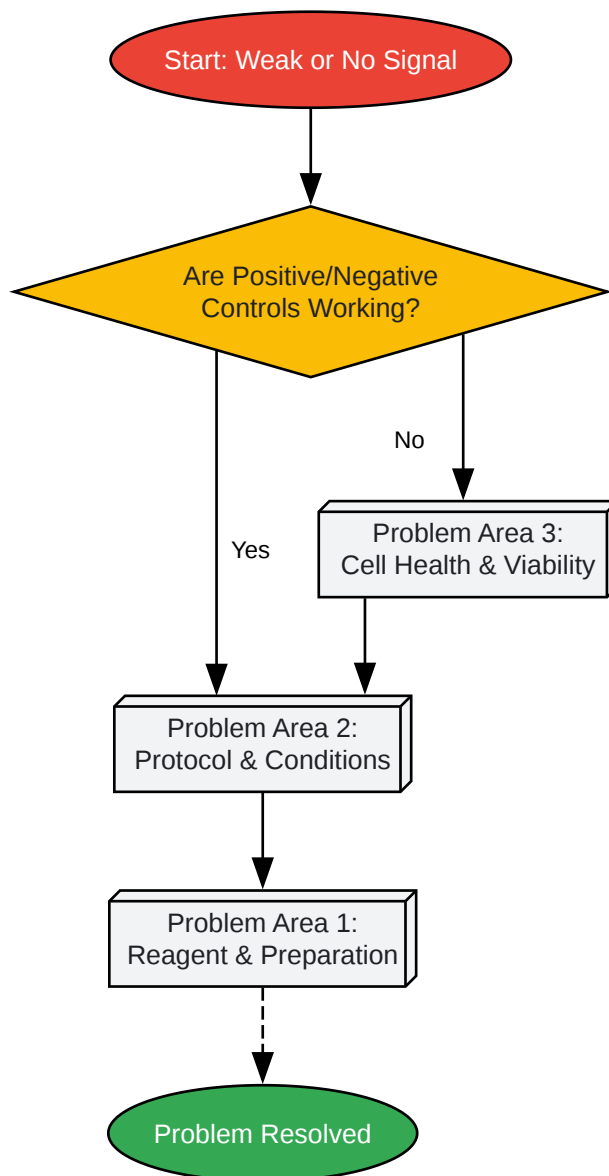

[Click to download full resolution via product page](#)

Caption: Systematic troubleshooting workflow.

## Key Experimental Protocol: Measuring SOCE Inhibition by 2-APB

This protocol provides a generalized workflow for assessing the inhibitory effect of high-concentration 2-APB on SOCE in adherent cells using a fluorescent calcium indicator.

#### Materials:

- Adherent cells cultured on glass-bottom imaging dishes.
- Fluorescent calcium indicator (e.g., Fluo-4 AM).
- Pluronic F-127.
- HEPES-buffered saline (HBS):  $\text{Ca}^{2+}$ -free and  $\text{Ca}^{2+}$ -containing (e.g., 2 mM  $\text{CaCl}_2$ ).
- Thapsigargin (SERCA inhibitor).
- 2-Aminoethyl diphenylborinate (2-APB).
- Ionophore (e.g., Ionomycin) for maximal fluorescence control ( $F_{\text{max}}$ ).
- EGTA for minimal fluorescence control ( $F_{\text{min}}$ ).

#### Procedure:

- Cell Preparation:
  - Seed cells on imaging dishes to achieve 70-80% confluency on the day of the experiment.
- Dye Loading:
  - Prepare a loading solution of Fluo-4 AM (e.g., 2-5  $\mu\text{M}$ ) with Pluronic F-127 (e.g., 0.02%) in serum-free medium or HBS.
  - Wash cells once with HBS.
  - Incubate cells with the loading solution for 30-45 minutes at 37°C.
  - Wash cells twice with HBS to remove excess dye and allow for de-esterification for 15-20 minutes.

- Baseline Measurement:
  - Mount the dish on a fluorescence microscope equipped for live-cell imaging.
  - Perfuse the cells with Ca<sup>2+</sup>-free HBS.
  - Record baseline fluorescence (F<sub>0</sub>) for 2-5 minutes.
- ER Store Depletion:
  - Add thapsigargin (e.g., 1-2 μM) to the Ca<sup>2+</sup>-free HBS to passively deplete ER calcium stores. A transient increase in cytosolic calcium should be observed as calcium leaks from the ER.
  - Continue recording until the signal returns to baseline.
- 2-APB Application:
  - Pre-incubate the cells with 2-APB at an inhibitory concentration (e.g., 50-100 μM) in Ca<sup>2+</sup>-free HBS for 5-10 minutes. This is the "Test" condition.
  - For the "Control" condition, pre-incubate with vehicle (DMSO) only.
- Induction of SOCE:
  - Switch the perfusion buffer to HBS containing 2 mM CaCl<sub>2</sub> (while maintaining the presence of 2-APB or vehicle).
  - Record the fluorescence signal. A robust and sustained increase in fluorescence in the control condition indicates SOCE. A significantly blunted or absent rise in the 2-APB condition demonstrates inhibition.
- Data Normalization and Analysis:
  - At the end of the experiment, obtain F<sub>max</sub> by adding a calcium ionophore like Ionomycin, and F<sub>min</sub> by adding a calcium chelator like EGTA.

- The change in fluorescence is typically reported as a ratio ( $F/F_0$ ) or as a normalized change ( $\Delta F/F_0 = (F - F_0) / F_0$ ).<sup>[7]</sup>

## References

- A highly sensitive fluorescent indicator dye for calcium imaging of neural activity in vitro and in vivo. National Institutes of Health (NIH).
- Precision calcium imaging of dense neural populations via a cell body-targeted calcium indicator. PubMed Central.
- A comparison of neuronal population dynamics measured with calcium imaging and electrophysiology. PLOS Computational Biology.
- Synthesis and Pharmacological Characterization of 2-Aminoethyl Diphenylborinate (2-APB) Derivatives for Inhibition of Store-Operated Calcium Entry (SOCE) in MDA-MB-231 Breast Cancer Cells. MDPI.
- 2-Aminoethyl diphenylborinate 97 524-95-8. Sigma-Aldrich.
- Western Blot Troubleshooting: Weak/No Signal & Other. Proteintech Group.
- Western Blot Troubleshoot: Faint Bands or Weak Signal. Bio-Rad Antibodies.
- Synthesis and Pharmacological Characterization of 2-Aminoethyl Diphenylborinate (2-APB) Derivatives for Inhibition of Store-Operated Calcium Entry (SOCE) in MDA-MB-231 Breast Cancer Cells. PubMed.
- Detection and Analysis of Reactive Oxygen Species (ROS): Buffer Components Are Not Bystanders. ChemRxiv.
- Calcium imaging: a technique to monitor calcium dynamics in biological systems. PubMed Central.
- Calcium imaging: Unraveling the neurobiological mechanisms of depression across cellular and circuit dimensions. PubMed.
- Synthesis and Pharmacological Characterization of 2-Aminoethyl Diphenylborinate (2-APB) Derivatives for Inhibition of Store-Operated Calcium Entry (SOCE) in MDA-MB-231 Breast Cancer Cells. ResearchGate.
- 2-Aminoethyl diphenylborinate. Chem-Impex.
- 2-Aminoethyl Diphenylborinate. Tokyo Chemical Industry (India) Pvt. Ltd..
- 2-Aminoethyl diphenylborinate. Sigma-Aldrich.
- 2-Aminoethyl diphenylborinate 97 524-95-8. Sigma-Aldrich.

### Need Custom Synthesis?

BenchChem offers custom synthesis for rare earth carbides and specific isotopic labeling.

Email: [info@benchchem.com](mailto:info@benchchem.com) or [Request Quote Online](#).

## Sources

- 1. 2-氨基乙酯二苯基硼酸-提供多种分子大小 [sigmaaldrich.com]
- 2. chemimpex.com [chemimpex.com]
- 3. mdpi.com [mdpi.com]
- 4. Synthesis and Pharmacological Characterization of 2-Aminoethyl Diphenylborinate (2-APB) Derivatives for Inhibition of Store-Operated Calcium Entry (SOCE) in MDA-MB-231 Breast Cancer Cells - PubMed [pubmed.ncbi.nlm.nih.gov]
- 5. researchgate.net [researchgate.net]
- 6. 2-Aminoethyl Diphenylborinate | 524-95-8 | Tokyo Chemical Industry (India) Pvt. Ltd. [tcichemicals.com]
- 7. A highly sensitive fluorescent indicator dye for calcium imaging of neural activity in vitro and in vivo - PMC [pmc.ncbi.nlm.nih.gov]
- 8. Precision calcium imaging of dense neural populations via a cell body-targeted calcium indicator - PMC [pmc.ncbi.nlm.nih.gov]
- 9. A comparison of neuronal population dynamics measured with calcium imaging and electrophysiology | PLOS Computational Biology [journals.plos.org]
- 10. Calcium imaging: a technique to monitor calcium dynamics in biological systems - PMC [pmc.ncbi.nlm.nih.gov]
- 11. Calcium imaging: Unraveling the neurobiological mechanisms of depression across cellular and circuit dimensions - PubMed [pubmed.ncbi.nlm.nih.gov]
- 12. chemrxiv.org [chemrxiv.org]
- 13. Western Blot Troubleshooting: Weak/No Signal & Other | Proteintech Group [ptglab.com]
- 14. bio-rad-antibodies.com [bio-rad-antibodies.com]
- To cite this document: BenchChem. [Technical Support Center: Troubleshooting Signal Integrity with Diphenylborinate Compounds]. BenchChem, [2026]. [Online PDF]. Available at: [https://www.benchchem.com/product/b174338/docs#technical-support-center-troubleshooting-signal-integrity-with-diphenylborinate-compounds]

---

### Disclaimer & Data Validity:

The information provided in this document is for Research Use Only (RUO) and is strictly not intended for diagnostic or therapeutic procedures. While BenchChem strives to provide

accurate protocols, we make no warranties, express or implied, regarding the fitness of this product for every specific experimental setup.

**Technical Support:** The protocols provided are for reference purposes. Unsure if this reagent suits your experiment?

**Need Industrial/Bulk Grade?** [Request Custom Synthesis Quote](#)

## BenchChem

Our mission is to be the trusted global source of essential and advanced chemicals, empowering scientists and researchers to drive progress in science and industry.

### Contact

Address: 3281 E Guasti Rd

Ontario, CA 91761, United States

Phone: (601) 213-4426

Email: [info@benchchem.com](mailto:info@benchchem.com)

[Contact our Ph.D. Support Team for a compatibility check](#)