

# Spectroscopic Characterization of Benzyl 4-iodobenzoate: A Technical Guide

**Author:** BenchChem Technical Support Team. **Date:** May 2026

## Compound of Interest

Compound Name: *Benzyl 4-iodobenzoate*

CAS No.: *136618-42-3*

Cat. No.: *B173212*

[Get Quote](#)

This technical guide provides an in-depth analysis of the spectroscopic data for **Benzyl 4-iodobenzoate**, a key intermediate in various fields of chemical synthesis. Designed for researchers, scientists, and professionals in drug development, this document elucidates the structural features of the molecule through the interpretation of Nuclear Magnetic Resonance (NMR), Infrared (IR), and Mass Spectrometry (MS) data. The insights provided herein are grounded in established spectroscopic principles and comparative analysis with structurally related compounds.

## Molecular Structure and Spectroscopic Overview

**Benzyl 4-iodobenzoate** ( $C_{14}H_{11}IO_2$ ) is an aromatic ester with a molecular weight of 338.14 g/mol [1]. Its structure comprises a benzyl alcohol moiety esterified with 4-iodobenzoic acid. This unique combination of a halogenated aromatic ring and a benzyl ester group gives rise to a distinct spectroscopic fingerprint, which is crucial for its unambiguous identification and quality control in synthetic applications.

### Molecular Structure of **Benzyl 4-iodobenzoate**

Caption: Chemical structure of **Benzyl 4-iodobenzoate**.

## Nuclear Magnetic Resonance (NMR) Spectroscopy

NMR spectroscopy is a powerful tool for elucidating the carbon-hydrogen framework of a molecule. For **Benzyl 4-iodobenzoate**, both  $^1\text{H}$  and  $^{13}\text{C}$  NMR provide critical information for structural confirmation.

### $^1\text{H}$ NMR Spectroscopy

The  $^1\text{H}$  NMR spectrum of **Benzyl 4-iodobenzoate** is expected to show distinct signals for the aromatic protons of both the benzoate and benzyl moieties, as well as a characteristic singlet for the benzylic methylene protons. A patent describing the synthesis of this compound reports the following  $^1\text{H}$  NMR data in  $\text{DMSO}-d_6$ :  $\delta$  ppm: 7.92 (d, 2H), 7.74 (d, 2H), 7.46 (d, 2H), 7.35-7.42 (m, 3H), 5.34 (s, 2H)[2].

Table 1: Predicted  $^1\text{H}$  NMR Spectral Data for **Benzyl 4-iodobenzoate**

Chemical Shift ( $\delta$ ) ppm	Multiplicity	Integration	Assignment
~7.90	Doublet	2H	Aromatic protons ortho to the ester group
~7.75	Doublet	2H	Aromatic protons meta to the ester group
~7.45	Multiplet	5H	Aromatic protons of the benzyl group
~5.35	Singlet	2H	Benzylic methylene protons (-CH <sub>2</sub> -)

Rationale for Predicted Chemical Shifts: The predicted chemical shifts are based on the analysis of related compounds. The downfield shift of the aromatic protons on the 4-iodobenzoate ring is due to the electron-withdrawing effect of the ester group. The protons of

the benzyl group are expected to appear in the typical aromatic region. The benzylic protons are deshielded by the adjacent oxygen atom, resulting in a chemical shift around 5.35 ppm.

## <sup>13</sup>C NMR Spectroscopy

The <sup>13</sup>C NMR spectrum will provide information about the carbon skeleton of the molecule.

Table 2: Predicted <sup>13</sup>C NMR Spectral Data for **Benzyl 4-iodobenzoate**

Chemical Shift (δ) ppm	Assignment
~165	Carbonyl carbon (C=O)
~138	Aromatic carbon attached to iodine
~136	Quaternary aromatic carbon of the benzyl group
~131	Aromatic carbons ortho to the ester group
~129	Aromatic carbons of the benzyl group
~128	Quaternary aromatic carbon of the benzoate group
~100	Aromatic carbons meta to the ester group
~67	Benzylic carbon (-CH <sub>2</sub> -)

Rationale for Predicted Chemical Shifts: The chemical shift of the carbonyl carbon is characteristic for esters. The carbons of the 4-iodobenzoate ring will show distinct signals, with the carbon attached to the iodine being significantly shifted. The chemical shifts for the benzyl group carbons are based on known values for similar benzyl esters[3].

### Experimental Protocol for NMR Data Acquisition

A standard protocol for acquiring NMR spectra involves dissolving a small amount of the sample (5-10 mg) in a deuterated solvent (e.g., CDCl<sub>3</sub> or DMSO-d<sub>6</sub>) in an NMR tube. The spectra are then recorded on a spectrometer, typically operating at a frequency of 300 MHz or higher for <sup>1</sup>H NMR and 75 MHz or higher for <sup>13</sup>C NMR.

## Infrared (IR) Spectroscopy

IR spectroscopy is used to identify the functional groups present in a molecule. The IR spectrum of **Benzyl 4-iodobenzoate** will be dominated by the characteristic stretching vibrations of the ester group.

Table 3: Predicted IR Absorption Bands for **Benzyl 4-iodobenzoate**

Wavenumber (cm <sup>-1</sup> )	Intensity	Assignment
~3050	Medium	Aromatic C-H stretch
~2950	Weak	Aliphatic C-H stretch
~1720	Strong	C=O (ester) stretch
~1600, ~1480	Medium	Aromatic C=C stretch
~1270	Strong	C-O (ester) stretch
~1100	Strong	C-O (ester) stretch
~850	Strong	C-I stretch

Rationale for Predicted Absorption Bands: The strong absorption around 1720 cm<sup>-1</sup> is a hallmark of the carbonyl group in an aromatic ester[4]. The C-O stretching vibrations of the ester are also prominent. The aromatic C-H and C=C stretching vibrations will be present in their expected regions. The C-I stretch is expected at a lower wavenumber.

### Experimental Protocol for IR Data Acquisition

The IR spectrum can be obtained using an FTIR spectrometer. A small amount of the solid sample can be analyzed directly using an Attenuated Total Reflectance (ATR) accessory, or by preparing a KBr pellet.

## Mass Spectrometry (MS)

Mass spectrometry provides information about the molecular weight and fragmentation pattern of a molecule, which aids in its structural elucidation.

Table 4: Predicted Key Fragment Ions in the Mass Spectrum of **Benzyl 4-iodobenzoate**

m/z	Proposed Fragment
338	[M] <sup>+</sup> (Molecular ion)
231	[M - C <sub>7</sub> H <sub>7</sub> ] <sup>+</sup>
107	[C <sub>7</sub> H <sub>7</sub> O] <sup>+</sup>
91	[C <sub>7</sub> H <sub>7</sub> ] <sup>+</sup> (Tropylium ion)
77	[C <sub>6</sub> H <sub>5</sub> ] <sup>+</sup>

Rationale for Predicted Fragmentation: The molecular ion peak is expected at m/z 338. A common fragmentation pathway for benzyl esters is the cleavage of the benzyl group, leading to the formation of the stable tropylium ion at m/z 91. Another significant fragmentation would be the loss of the benzyl radical to give the 4-iodobenzoyl cation at m/z 231. Further fragmentation of the benzyl portion can lead to the phenyl cation at m/z 77[5].

#### Fragmentation Pathway of **Benzyl 4-iodobenzoate** in Mass Spectrometry

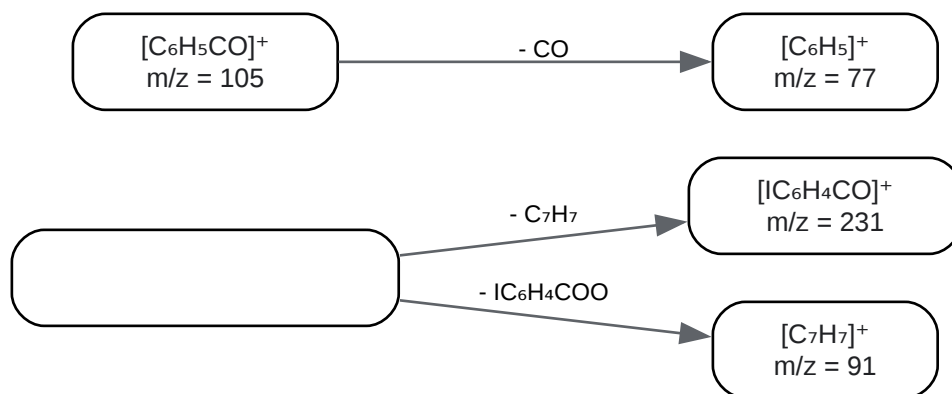

[Click to download full resolution via product page](#)

Caption: Proposed fragmentation pathway of **Benzyl 4-iodobenzoate**.

Experimental Protocol for Mass Spectrometry Data Acquisition

Mass spectra are typically acquired using an electron ionization (EI) source coupled with a mass analyzer such as a quadrupole or time-of-flight (TOF) detector. The sample is introduced into the ion source, where it is vaporized and ionized. The resulting ions are then separated based on their mass-to-charge ratio.

## Conclusion

The comprehensive spectroscopic analysis presented in this guide, based on predicted data from analogous compounds and established principles, provides a robust framework for the characterization of **Benzyl 4-iodobenzoate**. The combination of NMR, IR, and MS data offers a detailed and self-validating system for confirming the structure and purity of this important chemical intermediate. Researchers and scientists can utilize this guide as a reliable reference for their synthetic and analytical endeavors.

## References

- BenchChem. (2025). Spectroscopic Comparison of Benzyl Stearate and Alternative Long-Chain Fatty Acid Esters.
- BenchChem. (2025). Spectroscopic and Synthetic Profile of Diphenylmethylene-Glycine Benzyl Ester: A Technical Guide.
- BenchChem. (2025). Mass Spectrometry Fragmentation of 4-Iodobenzyl Alcohol: A Technical Guide.
- Royal Society of Chemistry. (n.d.). Supporting Information.
- Royal Society of Chemistry. (n.d.). Supporting Information.
- Sigma-Aldrich. (n.d.). **Benzyl 4-iodobenzoate**.
- ChemicalBook. (n.d.). Benzyl4-iodobenzoate CAS#: 136618-42-3.
- CP Lab Safety. (n.d.). **Benzyl 4-iodobenzoate**, min 95%, 1 gram.
- BenchChem. (2025). An In-depth Technical Guide to the Infrared Spectroscopy Analysis of Ethyl 4-iodobenzoate.

### *Need Custom Synthesis?*

*BenchChem offers custom synthesis for rare earth carbides and specific isotopic labeling.*

*Email: [info@benchchem.com](mailto:info@benchchem.com) or [Request Quote Online](#).*

## Sources

- [1. calpaclab.com \[calpaclab.com\]](https://calpaclab.com)
- [2. Benzyl 4-iodobenzoate CAS#: 136618-42-3 \[chemicalbook.com\]](https://chemicalbook.com)
- [3. rsc.org \[rsc.org\]](https://rsc.org)
- [4. pdf.benchchem.com \[pdf.benchchem.com\]](https://pdf.benchchem.com)
- [5. pdf.benchchem.com \[pdf.benchchem.com\]](https://pdf.benchchem.com)
- To cite this document: BenchChem. [Spectroscopic Characterization of Benzyl 4-iodobenzoate: A Technical Guide]. BenchChem, [2026]. [Online PDF]. Available at: [<https://www.benchchem.com/product/b173212/docs#spectroscopic-characterization-of-benzyl-4-iodobenzoate-a-technical-guide>]

---

### Disclaimer & Data Validity:

The information provided in this document is for Research Use Only (RUO) and is strictly not intended for diagnostic or therapeutic procedures. While BenchChem strives to provide accurate protocols, we make no warranties, express or implied, regarding the fitness of this product for every specific experimental setup.

**Technical Support:** The protocols provided are for reference purposes. Unsure if this reagent suits your experiment?

**Need Industrial/Bulk Grade?** [Request Custom Synthesis Quote](#)

## BenchChem

Our mission is to be the trusted global source of essential and advanced chemicals, empowering scientists and researchers to drive progress in science and industry.

### Contact

Address: 3281 E Guasti Rd

Ontario, CA 91761, United States

Phone: (601) 213-4426

Email: [info@benchchem.com](mailto:info@benchchem.com)

Contact our Ph.D. Support Team for a compatibility check