

Application Notes and Protocols: Thiol Group Functionalization of 3-Fluoro-4-mercaptobenzonitrile

Author: BenchChem Technical Support Team. **Date:** May 2026

Compound of Interest

Compound Name: 3-Fluoro-4-mercaptobenzonitrile

CAS No.: 110888-16-9

Cat. No.: B173716

[Get Quote](#)

Introduction: The Strategic Importance of 3-Fluoro-4-mercaptobenzonitrile in Synthesis

3-Fluoro-4-mercaptobenzonitrile is a versatile scaffold in medicinal chemistry and materials science. Its unique trifunctional nature, featuring a nitrile group, a fluorine atom, and a nucleophilic thiol group, offers a rich platform for molecular elaboration. The thiol group, in particular, serves as a key handle for a variety of functionalization reactions, enabling the synthesis of diverse thioether and disulfide derivatives. These derivatives are of significant interest in drug discovery, where the thioether linkage can enhance metabolic stability and modulate biological activity, and in materials science for the development of novel polymers and functional surfaces.^{[1][2][3]}

This guide provides a comprehensive overview of the key strategies for the functionalization of the thiol group of **3-Fluoro-4-mercaptobenzonitrile**, complete with detailed experimental protocols, mechanistic insights, and discussions on the applications of the resulting products.

Core Functionalization Strategies

The reactivity of the thiol group in **3-Fluoro-4-mercaptobenzonitrile** can be harnessed through several key reaction classes:

- S-Alkylation: Formation of a thioether bond by reaction with an alkyl halide.
- S-Arylation: Formation of a diaryl sulfide through coupling with an aryl halide or boronic acid.
- Disulfide Bond Formation: Oxidative coupling to form a symmetrical disulfide.
- Michael Addition: Conjugate addition to an α,β -unsaturated carbonyl compound.

The following sections will delve into the specifics of each of these transformations.

S-Alkylation: Synthesis of 3-Fluoro-4-(alkylthio)benzonitriles

S-alkylation is a fundamental transformation that introduces an alkyl substituent onto the sulfur atom, yielding a thioether. This reaction typically proceeds via an SN2 mechanism, where the thiolate anion, generated in situ by a base, acts as a potent nucleophile.

Causality in Experimental Design:

The choice of base is critical to efficiently deprotonate the thiol without promoting side reactions. Inorganic bases such as potassium carbonate or sodium hydride are commonly employed. The reaction solvent should be polar aprotic to solvate the cation of the base and facilitate the nucleophilic attack. The selection of the alkylating agent will directly determine the nature of the introduced side chain.

Experimental Protocol: S-Alkylation with Benzyl Bromide

This protocol details the synthesis of 3-Fluoro-4-(benzylthio)benzonitrile.

Materials:

Reagent/Solvent	Molecular Weight (g/mol)	Amount (mmol)	Volume/Mass
3-Fluoro-4-mercaptobenzonitrile	153.18	1.0	153 mg
Potassium Carbonate (K ₂ CO ₃)	138.21	1.5	207 mg
Benzyl Bromide	171.04	1.1	188 mg (0.13 mL)
N,N-Dimethylformamide (DMF)	73.09	-	5 mL
Diethyl Ether	74.12	-	50 mL
Saturated Sodium Bicarbonate Solution	-	-	20 mL
Brine	-	-	20 mL
Anhydrous Magnesium Sulfate (MgSO ₄)	120.37	-	-

Procedure:

- To a stirred solution of **3-Fluoro-4-mercaptobenzonitrile** (1.0 mmol) in DMF (5 mL) in a round-bottom flask, add potassium carbonate (1.5 mmol).
- Stir the mixture at room temperature for 15 minutes to facilitate the formation of the thiolate.
- Add benzyl bromide (1.1 mmol) dropwise to the reaction mixture.
- Stir the reaction at room temperature for 4-6 hours. Monitor the reaction progress by thin-layer chromatography (TLC).
- Upon completion, pour the reaction mixture into water (20 mL) and extract with diethyl ether (2 x 25 mL).

- Wash the combined organic layers with saturated sodium bicarbonate solution (20 mL) and brine (20 mL).
- Dry the organic layer over anhydrous magnesium sulfate, filter, and concentrate under reduced pressure.
- Purify the crude product by column chromatography on silica gel (eluent: hexane/ethyl acetate gradient) to afford the pure 3-Fluoro-4-(benzylthio)benzonitrile.

Characterization Data (Hypothetical):

- ^1H NMR (400 MHz, CDCl_3): δ 7.50-7.40 (m, 2H, Ar-H), 7.35-7.25 (m, 5H, Ar-H of benzyl), 7.10 (t, $J = 8.8$ Hz, 1H, Ar-H), 4.15 (s, 2H, SCH_2).
- ^{13}C NMR (101 MHz, CDCl_3): δ 162.5 (d, $J = 252.5$ Hz, C-F), 136.0, 134.0, 130.0, 129.0, 128.5, 127.5, 118.0 (d, $J = 22.2$ Hz, C-H), 115.0 (d, $J = 3.0$ Hz, C-CN), 105.0 (C-CN), 38.0 (SCH_2).
- FT-IR (ATR, cm^{-1}): 2225 ($\text{C}\equiv\text{N}$ stretch), 1580, 1480, 1450 (aromatic $\text{C}=\text{C}$ stretch).
- MS (ESI): m/z 244.07 $[\text{M}+\text{H}]^+$.

Experimental Workflow: S-Alkylation



[Click to download full resolution via product page](#)

Caption: S-Alkylation Workflow

S-Arylation: Synthesis of 3-Fluoro-4-(arythio)benzonitriles

S-arylation to form diaryl sulfides is a powerful C-S bond-forming reaction. Transition metal-catalyzed cross-coupling reactions, particularly with copper or palladium catalysts, are the most common methods.^{[4][5]}

Causality in Experimental Design:

Copper-catalyzed S-arylation often provides a cost-effective and efficient route. The choice of ligand, such as 1,10-phenanthroline, can significantly enhance the catalytic activity. The base is crucial for both the deprotonation of the thiol and for facilitating the catalytic cycle. A variety of aryl halides can be used as coupling partners.

Experimental Protocol: Copper-Catalyzed S-Arylation with 4-Iodoanisole

This protocol describes the synthesis of 3-Fluoro-4-(4-methoxyphenylthio)benzonitrile.

Materials:

Reagent/Solvent	Molecular Weight (g/mol)	Amount (mmol)	Volume/Mass
3-Fluoro-4-mercaptobenzonitrile	153.18	1.0	153 mg
4-Iodoanisole	234.04	1.2	281 mg
Copper(I) Iodide (CuI)	190.45	0.1	19 mg
1,10-Phenanthroline	180.21	0.2	36 mg
Cesium Carbonate (Cs ₂ CO ₃)	325.82	2.0	652 mg
Toluene	92.14	-	5 mL
Ethyl Acetate	88.11	-	50 mL
Water	18.02	-	20 mL
Brine	-	-	20 mL
Anhydrous Sodium Sulfate (Na ₂ SO ₄)	142.04	-	-

Procedure:

- In a sealable reaction tube, combine **3-Fluoro-4-mercaptobenzonitrile** (1.0 mmol), 4-iodoanisole (1.2 mmol), CuI (0.1 mmol), 1,10-phenanthroline (0.2 mmol), and cesium carbonate (2.0 mmol).
- Evacuate and backfill the tube with an inert gas (e.g., nitrogen or argon).
- Add toluene (5 mL) via syringe.
- Seal the tube and heat the reaction mixture at 110 °C for 12-18 hours with vigorous stirring.
- After cooling to room temperature, dilute the mixture with ethyl acetate (25 mL) and filter through a pad of Celite.

- Wash the filtrate with water (20 mL) and brine (20 mL).
- Dry the organic layer over anhydrous sodium sulfate, filter, and concentrate under reduced pressure.
- Purify the residue by column chromatography on silica gel (eluent: hexane/ethyl acetate gradient) to yield the desired diaryl sulfide.

Characterization Data (Hypothetical):

- ^1H NMR (400 MHz, CDCl_3): δ 7.60-7.50 (m, 2H, Ar-H), 7.45-7.35 (m, 2H, Ar-H), 7.20 (t, J = 8.8 Hz, 1H, Ar-H), 6.95-6.85 (m, 2H, Ar-H), 3.80 (s, 3H, OCH_3).
- ^{13}C NMR (101 MHz, CDCl_3): δ 162.0 (d, J = 250.5 Hz, C-F), 160.0, 135.0, 133.0, 131.0, 128.0, 120.0 (d, J = 21.2 Hz, C-H), 115.0, 114.0 (d, J = 3.0 Hz, C-CN), 104.0 (C-CN), 55.5 (OCH_3).
- FT-IR (ATR, cm^{-1}): 2228 ($\text{C}\equiv\text{N}$ stretch), 1590, 1490, 1250 (aromatic $\text{C}=\text{C}$ and $\text{C}-\text{O}$ stretch).
- MS (ESI): m/z 260.06 $[\text{M}+\text{H}]^+$.

Reaction Mechanism: Copper-Catalyzed S-Arylation

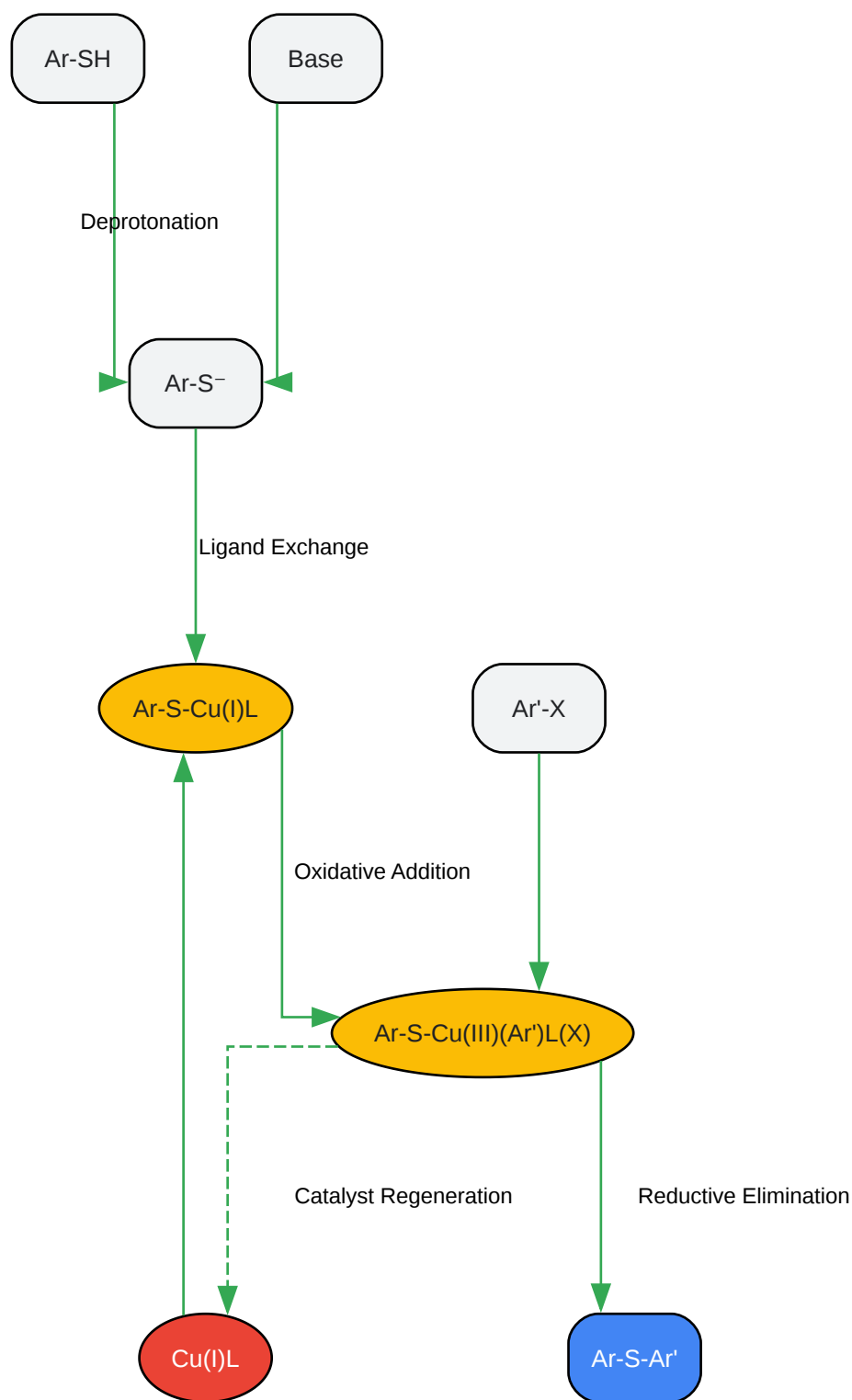

[Click to download full resolution via product page](#)

Caption: Copper-Catalyzed S-Arylation Cycle

Disulfide Bond Formation

The oxidation of thiols to disulfides is a common and important reaction. This transformation can be achieved using a variety of mild oxidizing agents. The resulting disulfide can be a stable final product or a protecting group for the thiol.[6][7]

Causality in Experimental Design:

Air oxidation in the presence of a base is a simple and environmentally friendly method, though it can be slow. For more controlled and faster reactions, reagents like iodine or dimethyl sulfoxide (DMSO) can be used. The choice of solvent can also influence the reaction rate.[8]

Experimental Protocol: Iodine-Mediated Oxidative Coupling

This protocol describes the synthesis of 4,4'-dithiobis(2-fluorobenzonitrile).

Materials:

Reagent/Solvent	Molecular Weight (g/mol)	Amount (mmol)	Volume/Mass
3-Fluoro-4-mercaptobenzonitrile	153.18	1.0	153 mg
Iodine (I ₂)	253.81	0.5	127 mg
Sodium Bicarbonate (NaHCO ₃)	84.01	2.0	168 mg
Methanol	32.04	-	10 mL
Dichloromethane (DCM)	84.93	-	20 mL
Saturated Sodium Thiosulfate Solution	-	-	10 mL
Water	18.02	-	20 mL
Brine	-	-	20 mL
Anhydrous Sodium Sulfate (Na ₂ SO ₄)	142.04	-	-

Procedure:

- Dissolve **3-Fluoro-4-mercaptobenzonitrile** (1.0 mmol) and sodium bicarbonate (2.0 mmol) in methanol (10 mL).
- To this solution, add a solution of iodine (0.5 mmol) in methanol (5 mL) dropwise at 0 °C.
- Stir the reaction mixture at room temperature for 1-2 hours, monitoring by TLC.
- Once the starting material is consumed, quench the reaction with a saturated aqueous solution of sodium thiosulfate to remove excess iodine.
- Remove the methanol under reduced pressure.
- Extract the aqueous residue with dichloromethane (2 x 10 mL).

- Wash the combined organic layers with water (20 mL) and brine (20 mL).
- Dry the organic phase over anhydrous sodium sulfate, filter, and evaporate the solvent to give the disulfide product, which can be further purified by recrystallization if necessary.

Characterization Data (Hypothetical):

- ^1H NMR (400 MHz, CDCl_3): δ 7.65-7.55 (m, 4H, Ar-H), 7.30 (t, J = 8.8 Hz, 2H, Ar-H).
- ^{13}C NMR (101 MHz, CDCl_3): δ 163.0 (d, J = 254.5 Hz, C-F), 138.0, 134.5, 120.0 (d, J = 22.0 Hz, C-H), 116.0 (d, J = 3.5 Hz, C-CN), 106.0 (C-CN).
- FT-IR (ATR, cm^{-1}): 2230 (C \equiv N stretch), 1575, 1475 (aromatic C=C stretch).
- MS (ESI): m/z 305.00 $[\text{M}+\text{H}]^+$.

Logical Relationship: Disulfide Formation

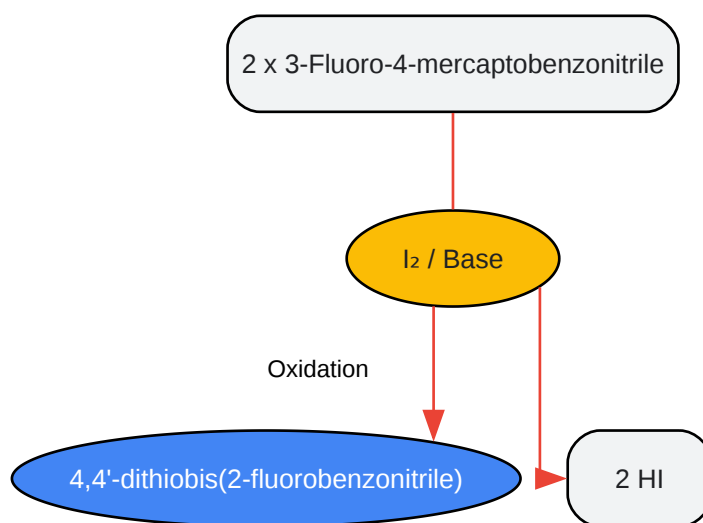

[Click to download full resolution via product page](#)

Caption: Disulfide Bond Formation

Thiol-Michael Addition

The thiol-Michael addition is a conjugate addition of a thiol to an α,β -unsaturated carbonyl compound. This reaction is highly efficient and proceeds under mild conditions, making it a

"click" reaction.[9][10][11]

Causality in Experimental Design:

The reaction is typically base-catalyzed, with a weak base like triethylamine (TEA) being sufficient to generate the nucleophilic thiolate. The choice of the Michael acceptor determines the functionality introduced at the β -position of the newly formed thioether. The reaction is often performed in a protic solvent like ethanol.

Experimental Protocol: Michael Addition to Methyl Acrylate

This protocol describes the synthesis of Methyl 3-((2-fluoro-4-cyanophenyl)thio)propanoate.

Materials:

Reagent/Solvent	Molecular Weight (g/mol)	Amount (mmol)	Volume/Mass
3-Fluoro-4-mercaptobenzonitrile	153.18	1.0	153 mg
Methyl Acrylate	86.09	1.2	103 mg (0.11 mL)
Triethylamine (TEA)	101.19	0.1	10 mg (0.014 mL)
Ethanol	46.07	-	5 mL
Ethyl Acetate	88.11	-	50 mL
1 M HCl (aq)	36.46	-	10 mL
Saturated Sodium Bicarbonate Solution	-	-	10 mL
Brine	-	-	10 mL
Anhydrous Magnesium Sulfate (MgSO ₄)	120.37	-	-

Procedure:

- To a solution of **3-Fluoro-4-mercaptobenzonitrile** (1.0 mmol) in ethanol (5 mL), add methyl acrylate (1.2 mmol).
- Add triethylamine (0.1 mmol) to the mixture.
- Stir the reaction at room temperature for 2-4 hours, monitoring by TLC.
- Upon completion, remove the ethanol under reduced pressure.
- Dissolve the residue in ethyl acetate (25 mL).
- Wash the organic layer with 1 M HCl (10 mL), saturated sodium bicarbonate solution (10 mL), and brine (10 mL).
- Dry the organic phase over anhydrous magnesium sulfate, filter, and concentrate in vacuo.
- Purify the product by column chromatography on silica gel (eluent: hexane/ethyl acetate gradient).

Characterization Data (Hypothetical):

- ^1H NMR (400 MHz, CDCl_3): δ 7.55-7.45 (m, 2H, Ar-H), 7.15 (t, $J = 8.8$ Hz, 1H, Ar-H), 3.70 (s, 3H, OCH_3), 3.20 (t, $J = 7.2$ Hz, 2H, SCH_2), 2.70 (t, $J = 7.2$ Hz, 2H, CH_2CO).
- ^{13}C NMR (101 MHz, CDCl_3): δ 172.0 (C=O), 162.8 (d, $J = 253.0$ Hz, C-F), 134.5, 132.0, 119.0 (d, $J = 22.5$ Hz, C-H), 115.5 (d, $J = 3.2$ Hz, C-CN), 105.5 (C-CN), 52.0 (OCH_3), 34.0 (SCH_2), 28.0 (CH_2CO).
- FT-IR (ATR, cm^{-1}): 2227 ($\text{C}\equiv\text{N}$ stretch), 1735 (C=O stretch), 1580, 1480 (aromatic C=C stretch).
- MS (ESI): m/z 240.06 $[\text{M}+\text{H}]^+$.

Reaction Pathway: Thiol-Michael Addition

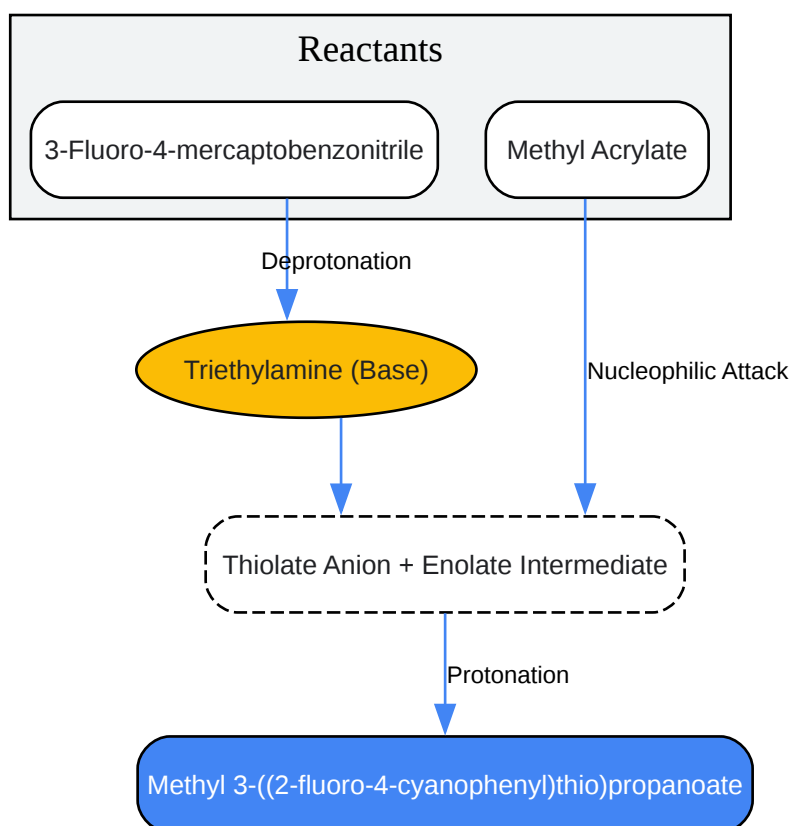

[Click to download full resolution via product page](#)

Caption: Thiol-Michael Addition Pathway

Applications in Drug Discovery and Bioconjugation

The functionalized derivatives of **3-Fluoro-4-mercaptobenzonitrile** are valuable in several areas of research and development:

- **Medicinal Chemistry:** Thioether derivatives are prevalent in pharmaceuticals due to their metabolic stability and ability to engage in specific interactions with biological targets.^{[2][3]} ^[12] The introduction of various alkyl and aryl groups allows for the modulation of lipophilicity and electronic properties, which are key determinants of pharmacokinetic and pharmacodynamic profiles. The nitrile group can also serve as a bioisostere for other functional groups or as a handle for further chemical modifications.
- **Bioconjugation:** The thiol group is a prime target for bioconjugation reactions, allowing for the attachment of the 3-fluoro-4-cyanophenyl moiety to biomolecules such as proteins and

peptides.[13] This is particularly relevant for the development of targeted drug delivery systems, diagnostic probes, and antibody-drug conjugates. The reactivity of the thiol can be finely tuned to achieve site-specific modifications.

Conclusion

3-Fluoro-4-mercaptobenzonitrile is a highly valuable building block for chemical synthesis. The strategic functionalization of its thiol group opens up a vast chemical space for the creation of novel molecules with diverse applications. The protocols outlined in this guide provide a solid foundation for researchers to explore the rich chemistry of this versatile compound. Careful consideration of the reaction conditions and purification techniques will ensure the successful synthesis and characterization of the desired derivatives.

References

- CN109400500B - Preparation method of 3-fluoro-4-methylbenzonitrile - Google P
- 3-Fluoro-4-(4-hydroxyphenoxy)benzonitrile - PMC - NIH. (URL: [\[Link\]](#))
- ChemInform Abstract: S-Arylation of Mercaptobenzimidazoles Using Cu(I) Catalysts - Experimental and Theoretical Observations. | Request PDF - ResearchGate. (URL: [\[Link\]](#))
- Trifluoromethyl ethers and -thioethers as tools for medicinal chemistry and drug discovery - PubMed. (URL: [\[Link\]](#))
- Analysis of Disulfide Bond Formation - PMC - NIH. (URL: [\[Link\]](#))
- Recent Advances in the Synthesis of Thioether | Request PDF - ResearchGate. (URL: [\[Link\]](#))
- S-arylation of 2-mercaptobenzazoles: a comprehensive review - ResearchGate. (URL: [\[Link\]](#))
- 2 - Organic Syntheses Procedure. (URL: [\[Link\]](#))
- High-field NMR spectroscopy and FTICR mass spectrometry - BG. (URL: [\[Link\]](#))
- Formation of Disulfide Bonds in Synthetic Peptides and Proteins. (URL: [\[Link\]](#))

- Novel Strategy for Non-Aqueous Bioconjugation of Substituted Phenyl-1,2,4-triazole-3,5-dione Analogues - PMC - NIH. (URL: [\[Link\]](#))
- Chapter 13 Spectroscopy NMR, IR, MS, UV-Vis. (URL: [\[Link\]](#))
- Medicinal chemistry-based perspectives on thiophene and its derivatives: exploring structural insights to discover plausible druggable leads - NIH. (URL: [\[Link\]](#))
- Synthesis of 3-Fluoro-4-(hydroxymethyl)benzotrile via Photobromination: Enabling Manufacturing Pathways for Danuglipron Starting Materials - ResearchGate. (URL: [\[Link\]](#))
- Synthesis of 3-fluorobenzoyl chloride functionalized magnetic sorbent for highly efficient enrichment of perfluorinated compounds from river water samples - PubMed. (URL: [\[Link\]](#))
- 23.10: Conjugate Additions- The Michael Reaction - Chemistry LibreTexts. (URL: [\[Link\]](#))
- Formation of Disulfide Bonds in Synthetic Peptides and Proteins - ResearchGate. (URL: [\[Link\]](#))
- Spectroscopic properties (FT-IR, NMR and UV) and DFT studies of amodiaquine - PMC. (URL: [\[Link\]](#))
- The Michael Addition Reaction and Conjugate Addition - Master Organic Chemistry. (URL: [\[Link\]](#))
- sulfide synthesis in preparation of unsymmetrical dialkyl disulfides - Organic Syntheses Procedure. (URL: [\[Link\]](#))
- Synthesis and Characterization of Some New 4-Hydroxy-coumarin Derivatives - MDPI. (URL: [\[Link\]](#))
- Organic Chemistry Ir And Nmr Cheat Sheet - Sema. (URL: [\[Link\]](#))
- MICHAEL ADDITION REACTION | MECHANISM | 1,4 | DONOR | ACCEPTOR | APPLICATIONS | ADICHEMISTRY. (URL: [\[Link\]](#))
- General synthetic strategy for regioselective ultrafast formation of disulfide bonds in peptides and proteins - PMC - NIH. (URL: [\[Link\]](#))

- Michael Addition Reaction Mechanism - YouTube. (URL: [\[Link\]](#))
- The Atmospheric Chemistry of Fluoroacetonitrile and the Characterization of the Major Product, Cyanoformyl Fluoride - MDPI. (URL: [\[Link\]](#))
- Effect of solvents on formation of disulphide bond in peptides - International Journal of Pharmaceutical Science Invention. (URL: [\[Link\]](#))

Need Custom Synthesis?

BenchChem offers custom synthesis for rare earth carbides and specific isotopic labeling.

Email: info@benchchem.com or [Request Quote Online](#).

Sources

1. 3-Fluoro-4-mercaptobenzonitrile | 110888-16-9 | Benchchem [benchchem.com]
 2. researchgate.net [researchgate.net]
 3. pdf.benchchem.com [pdf.benchchem.com]
 4. researchgate.net [researchgate.net]
 5. researchgate.net [researchgate.net]
 6. researchgate.net [researchgate.net]
 7. General synthetic strategy for regioselective ultrafast formation of disulfide bonds in peptides and proteins - PMC [[pmc.ncbi.nlm.nih.gov](https://pubmed.ncbi.nlm.nih.gov)]
 8. 186590-04-5 | 4-FLUORO-3-HYDROXYBENZONITRILE 98 [fluoromart.com]
 9. masterorganicchemistry.com [masterorganicchemistry.com]
 10. adichemistry.com [adichemistry.com]
 11. m.youtube.com [m.youtube.com]
 12. Medicinal chemistry-based perspectives on thiophene and its derivatives: exploring structural insights to discover plausible druggable leads - PMC [[pmc.ncbi.nlm.nih.gov](https://pubmed.ncbi.nlm.nih.gov)]
 13. Novel Strategy for Non-Aqueous Bioconjugation of Substituted Phenyl-1,2,4-triazole-3,5-dione Analogues - PMC [[pmc.ncbi.nlm.nih.gov](https://pubmed.ncbi.nlm.nih.gov)]
- To cite this document: BenchChem. [Application Notes and Protocols: Thiol Group Functionalization of 3-Fluoro-4-mercaptobenzonitrile]. BenchChem, [2026]. [Online PDF].

Available at: [<https://www.benchchem.com/product/b173716/docs#application-notes-and-protocols-thiol-group-functionalization-of-3-fluoro-4-mercaptobenzonitrile>]

Disclaimer & Data Validity:

The information provided in this document is for Research Use Only (RUO) and is strictly not intended for diagnostic or therapeutic procedures. While BenchChem strives to provide accurate protocols, we make no warranties, express or implied, regarding the fitness of this product for every specific experimental setup.

Technical Support: The protocols provided are for reference purposes. Unsure if this reagent suits your experiment?

Need Industrial/Bulk Grade? [Request Custom Synthesis Quote](#)

BenchChem

Our mission is to be the trusted global source of essential and advanced chemicals, empowering scientists and researchers to drive progress in science and industry.

Contact

Address: 3281 E Guasti Rd
Ontario, CA 91761, United States
Phone: (601) 213-4426
Email: info@benchchem.com

[Contact our Ph.D. Support Team for a compatibility check](#)