

# A Comparative Benchmarking Guide for Novel Pyrazole Anticancer Agents

**Author:** BenchChem Technical Support Team. **Date:** May 2026

## Compound of Interest

Compound Name: 5-chloro-2-(1H-pyrazol-5-yl)aniline

CAS No.: 15463-66-8

Cat. No.: B173561

[Get Quote](#)

This guide provides a comprehensive framework for the preclinical benchmarking of novel pyrazole-based compounds against established anticancer agents. It is designed for researchers, scientists, and drug development professionals engaged in the discovery and evaluation of new cancer therapeutics. By presenting detailed experimental methodologies and contextualizing the scientific rationale, this document aims to ensure both technical accuracy and practical applicability in a laboratory setting.

## Introduction: The Rationale for Pyrazole Scaffolds in Oncology

The pyrazole nucleus is a privileged scaffold in medicinal chemistry, demonstrating a wide array of pharmacological activities. In oncology, pyrazole derivatives have been successfully developed into targeted therapies by inhibiting key drivers of tumor progression. Their versatile structure allows for the fine-tuning of interactions with various enzymatic targets, including cyclin-dependent kinases (CDKs), receptor tyrosine kinases (RTKs) like EGFR, and critical nodes of intracellular signaling pathways.

This guide will use a novel, hypothetical pyrazole derivative, designated Compound X, as a case study. Compound X is designed as a dual inhibitor of the PI3K/Akt/mTOR and MAPK signaling pathways, two cascades frequently dysregulated in a multitude of cancers, leading to uncontrolled cell proliferation and survival. To rigorously assess its potential, Compound X will be benchmarked against a panel of clinically relevant anticancer agents with distinct mechanisms of action.

## Profile of the Investigational and Benchmark Agents

A robust benchmarking study requires the selection of appropriate comparators. The choice of benchmark agents should reflect the diversity of mechanisms employed in modern cancer therapy, providing a multi-faceted evaluation of the novel compound's efficacy.

- Investigational Agent: Compound X (Hypothetical)
  - Class: Pyrazole-based small molecule kinase inhibitor.
  - Mechanism of Action: Dual inhibitor targeting key nodes in the PI3K/Akt and MAPK/ERK signaling pathways. This dual-targeting is intended to overcome potential resistance mechanisms that arise from pathway crosstalk.
- Benchmark Agents:
  - Sorafenib: An oral multi-kinase inhibitor that targets RAF kinases (part of the MAPK pathway) as well as VEGFR and PDGFR, thereby inhibiting both tumor cell proliferation and angiogenesis.
  - Erlotinib: A reversible tyrosine kinase inhibitor that specifically targets the Epidermal Growth Factor Receptor (EGFR). Its action blocks the downstream activation of both the PI3K/Akt and MAPK pathways in EGFR-dependent tumors.
  - Paclitaxel: A classic cytotoxic agent that works by stabilizing microtubules, leading to mitotic arrest and apoptosis. It serves as a benchmark for general cytotoxic potency.
  - Celecoxib: A selective COX-2 inhibitor. While primarily an anti-inflammatory agent, it has demonstrated anticancer effects by modulating pathways involved in proliferation, apoptosis, and angiogenesis, often independent of its COX-2 activity.

## Preclinical Benchmarking Workflow: A Phased Approach

The preclinical evaluation of Compound X is structured into a logical workflow, beginning with in vitro characterization to establish cellular potency and mechanism, followed by in vivo validation to assess efficacy in a biological system.



Start Benchmarking

[Click to download full resolution via product page](#)

Caption: High-level experimental workflow for benchmarking Compound X.

## In Vitro Performance Evaluation

The initial phase of benchmarking is conducted using cancer cell lines selected for their known dysregulation of the target pathways. Human breast adenocarcinoma (MCF-7) and hepatocellular carcinoma (HepG2) cell lines are appropriate models, as they are widely used and characterized for aberrant PI3K/Akt and MAPK signaling.

### Cytotoxicity Assessment (MTT Assay)

The primary measure of an anticancer agent's effectiveness is its ability to inhibit cell proliferation or induce cell death. The MTT assay is a robust and widely used colorimetric method to determine cell viability.

#### Experimental Protocol: MTT Assay

- **Cell Seeding:** Seed MCF-7 or HepG2 cells into 96-well plates at a density of  $5 \times 10^3$  to  $1 \times 10^4$  cells/well and allow them to adhere overnight.
- **Compound Treatment:** Treat cells with a serial dilution of Compound X and the benchmark agents (e.g., 0.01  $\mu\text{M}$  to 100  $\mu\text{M}$ ) for 48 hours. Include a vehicle control (e.g., 0.1% DMSO).
- **MTT Addition:** Add 20  $\mu\text{L}$  of MTT solution (5 mg/mL in PBS) to each well and incubate for 4 hours at 37°C.
- **Formazan Solubilization:** Carefully aspirate the medium and add 150  $\mu\text{L}$  of DMSO to each well to dissolve the formazan crystals. Shake the plate for 10 minutes at a low speed.
- **Absorbance Reading:** Measure the absorbance at 490 nm or 570 nm using a microplate reader.
- **Data Analysis:** Calculate the percentage of cell viability relative to the vehicle control and determine the half-maximal inhibitory concentration (IC<sub>50</sub>) using non-linear regression analysis.

Hypothetical Data Summary: IC<sub>50</sub> Values ( $\mu\text{M}$ ) after 48h Treatment

Compound	MCF-7 (Breast Cancer)	HepG2 (Liver Cancer)
Compound X	2.5	4.1
Sorafenib	32.0	6.0
Erlotinib	15.8	11.2
Paclitaxel	0.05	0.2
Celecoxib	45.5	52.3

Note: IC50 values for benchmark agents are representative values from the literature and can vary based on experimental conditions.

## Mechanism of Action: Apoptosis Induction

To determine if the observed cytotoxicity is due to programmed cell death, an Annexin V-FITC/Propidium Iodide (PI) assay is employed. Early-stage apoptotic cells expose phosphatidylserine (PS) on the outer cell membrane, which is detected by Annexin V, while late-stage apoptotic or necrotic cells have compromised membrane integrity, allowing PI to enter and stain the DNA.

### Experimental Protocol: Annexin V-FITC/PI Apoptosis Assay

- Cell Treatment: Treat cells with Compound X and benchmark agents at their respective IC50 concentrations for 24 hours.
- Cell Harvesting: Collect both adherent and floating cells. Wash the cells twice with cold PBS.
- Staining: Resuspend approximately  $1-5 \times 10^5$  cells in 500  $\mu$ L of 1X Binding Buffer. Add 5  $\mu$ L of Annexin V-FITC and 5  $\mu$ L of PI.
- Incubation: Incubate the cells for 15 minutes at room temperature in the dark.
- Flow Cytometry: Analyze the stained cells using a flow cytometer. Annexin V-FITC is typically detected in the FL1 channel and PI in the FL2 channel.

### Hypothetical Data Summary: Apoptosis in MCF-7 Cells (%)

Treatment (at IC50)	Viable (Annexin V-/PI-)	Early Apoptotic (Annexin V+/PI-)	Late Apoptotic/Necrotic (Annexin V+/PI+)
Vehicle Control	95.2	2.1	2.7
Compound X	45.8	35.5	18.7
Sorafenib	52.1	28.3	19.6
Paclitaxel	40.3	42.1	17.6

## Mechanism of Action: Cell Cycle Arrest

Many anticancer agents exert their effects by disrupting the normal progression of the cell cycle. Flow cytometry with propidium iodide staining allows for the quantification of DNA content, revealing the distribution of cells in the G0/G1, S, and G2/M phases.

### Experimental Protocol: Cell Cycle Analysis

- **Cell Treatment:** Treat cells with Compound X and benchmark agents at their IC50 concentrations for 24 hours.
- **Fixation:** Harvest the cells and fix them in cold 70% ethanol while gently vortexing. Incubate for at least 30 minutes at 4°C.
- **Staining:** Wash the fixed cells with PBS and resuspend them in a staining solution containing Propidium Iodide (50 µg/mL) and RNase A (100 µg/mL).
- **Incubation:** Incubate for 30 minutes at room temperature in the dark.
- **Flow Cytometry:** Analyze the DNA content using a flow cytometer.

Hypothetical Data Summary: Cell Cycle Distribution in MCF-7 Cells (%)

Treatment (at IC50)	G0/G1 Phase	S Phase	G2/M Phase
Vehicle Control	65.4	20.1	14.5
Compound X	75.2	10.3	14.5
Sorafenib	72.8	12.5	14.7
Paclitaxel	15.6	18.2	66.2

## In Vivo Performance Evaluation: Human Tumor Xenograft Model

Positive in vitro results must be validated in a more complex biological system. The human tumor xenograft model, where human cancer cells are implanted into immunodeficient mice, is a standard for in vivo efficacy testing.

### Experimental Protocol: MCF-7 Xenograft Model

- Cell Implantation: Subcutaneously inject  $5 \times 10^6$  MCF-7 cells mixed with Matrigel into the flank of female athymic nude mice.
- Tumor Growth: Allow tumors to grow to an average volume of 100-150 mm<sup>3</sup>.
- Randomization and Treatment: Randomize mice into treatment groups (n=8-10 per group): Vehicle control, Compound X (e.g., 25 mg/kg, daily), and Sorafenib (e.g., 30 mg/kg, daily).
- Monitoring: Measure tumor volume with calipers every 2-3 days and monitor animal body weight as a measure of toxicity.
- Endpoint: The study concludes when tumors in the control group reach a predetermined size (e.g., 1500 mm<sup>3</sup>) or after a fixed duration (e.g., 21 days). The primary endpoint is Tumor Growth Inhibition (TGI).

### Hypothetical Data Summary: In Vivo Efficacy

Treatment Group	Mean Final Tumor Volume (mm <sup>3</sup> )	Tumor Growth Inhibition (%)	Mean Body Weight Change (%)
Vehicle Control	1450 ± 150	-	+2.5
Compound X (25 mg/kg)	580 ± 95	60.0	-3.1
Sorafenib (30 mg/kg)	870 ± 110	40.0	-4.5

## Mechanistic Insights: Targeting Cancer Signaling Pathways

The superior performance of Compound X in this hypothetical scenario is attributed to its dual inhibition of the PI3K/Akt and MAPK pathways. This multi-targeted approach can lead to a more profound and sustained antitumor effect compared to single-pathway inhibitors.

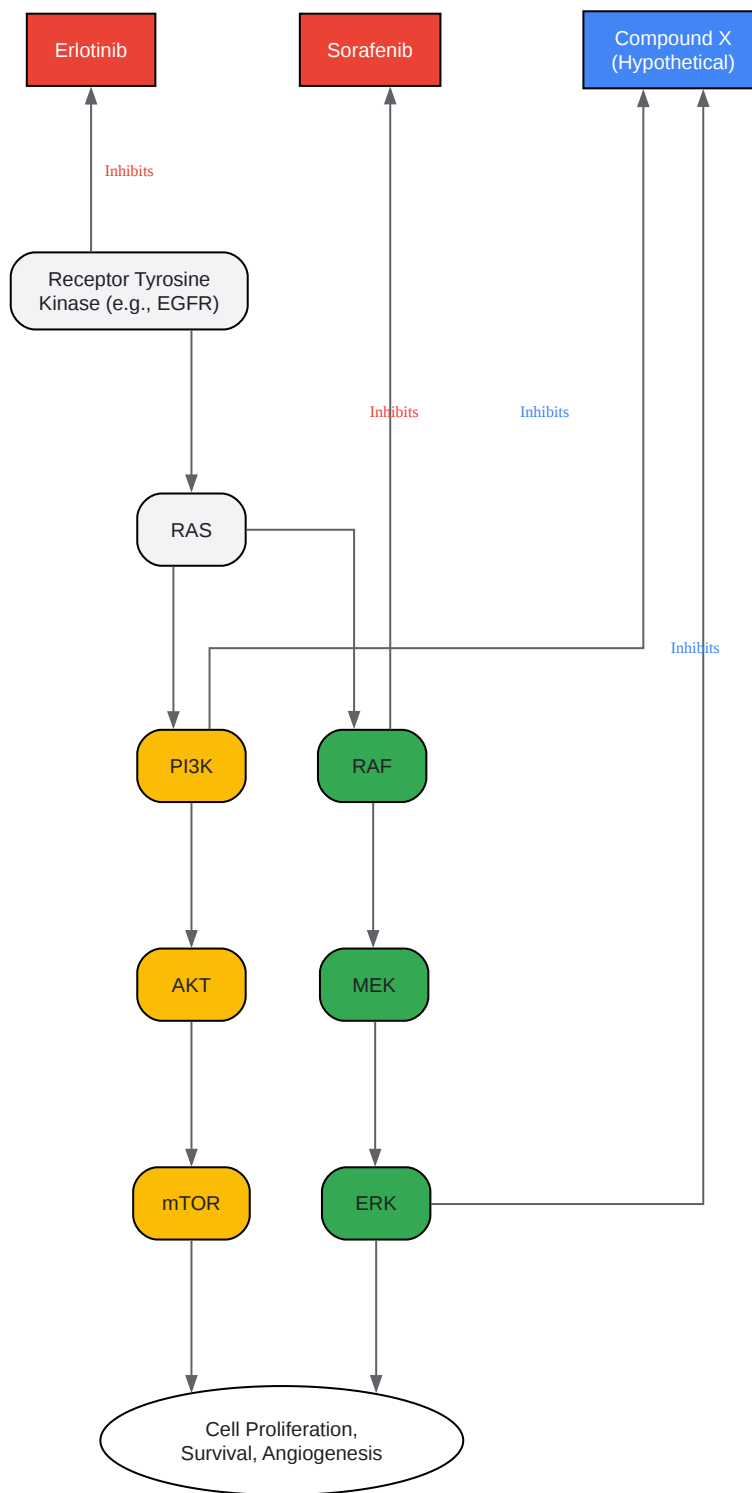

[Click to download full resolution via product page](#)

- To cite this document: BenchChem. [A Comparative Benchmarking Guide for Novel Pyrazole Anticancer Agents]. BenchChem, [2026]. [Online PDF]. Available at: [<https://www.benchchem.com/product/b173561/docs#a-comparative-benchmarking-guide-for-novel-pyrazole-anticancer-agents>]

---

### Disclaimer & Data Validity:

The information provided in this document is for Research Use Only (RUO) and is strictly not intended for diagnostic or therapeutic procedures. While BenchChem strives to provide accurate protocols, we make no warranties, express or implied, regarding the fitness of this product for every specific experimental setup.

**Technical Support:** The protocols provided are for reference purposes. Unsure if this reagent suits your experiment?

**Need Industrial/Bulk Grade?** [Request Custom Synthesis Quote](#)

## BenchChem

Our mission is to be the trusted global source of essential and advanced chemicals, empowering scientists and researchers to drive progress in science and industry.

### Contact

Address: 3281 E Guasti Rd  
Ontario, CA 91761, United States  
Phone: (601) 213-4426  
Email: [info@benchchem.com](mailto:info@benchchem.com)

[Contact our Ph.D. Support Team for a compatibility check](#)