

Technical Guide: Mechanism of Insecticidal Action of Gamma-HCH (Lindane)

Author: BenchChem Technical Support Team. **Date:** February 2026

Compound of Interest

Compound Name: Hexachlorocyclohexane

CAS No.: 119911-69-2

Cat. No.: B172972

[Get Quote](#)

Executive Summary

Gamma-hexachlorocyclohexane (

-HCH), historically known as Lindane, represents a pivotal case study in neurotoxicology. Although its use is now restricted under the Stockholm Convention due to persistence, understanding its mechanism provides the foundational model for designing modern GABA-ergic insecticides (e.g., fipronil, isoxazolines).

This guide dissects the molecular interaction between

-HCH and the insect GABA-gated chloride channel. Unlike organophosphates that inhibit enzymes (acetylcholinesterase), Lindane acts as a non-competitive antagonist (channel blocker). It physically occludes the transmembrane pore of the GABA receptor, preventing chloride influx, which destabilizes neuronal resting potential and leads to fatal hyperexcitation.

Molecular Architecture & Stereoselectivity

The insecticidal potency of HCH is strictly stereospecific. Technical grade HCH contains multiple isomers (ngcontent-ng-c3009699313="" _ngghost-ng-c3156237429="" class="inline ng-star-inserted">

), but only the

-isomer possesses significant insecticidal activity.

The "Lock-and-Key" Conformation

The cyclohexane ring of HCH adopts a chair conformation. The biological activity depends on the spatial arrangement of the six chlorine atoms:

- Gamma-HCH (Lindane): Possesses a specific aaaaee (axial-axial-axial-equatorial-equatorial-equatorial) configuration. This specific globular shape allows it to fit deeply within the hydrophobic lumen of the chloride channel.
- Delta-HCH: aaaaae configuration. While chemically similar, its steric bulk prevents it from accessing the binding site effectively.

Table 1: Comparative Activity of HCH Isomers

Isomer	Chlorine Configuration	Insecticidal Potency	Primary Biological Effect
-HCH	3 Axial, 3 Equatorial	High	Acute convulsant (GABA antagonist)
-HCH	2 Axial, 4 Equatorial	Low	CNS depressant/weak convulsant
-HCH	0 Axial, 6 Equatorial	Negligible	Bioaccumulation (highly stable)
-HCH	1 Axial, 5 Equatorial	Negligible	Cytotoxicity (non-neural)

Primary Mode of Action: The GABAergic Blockade

The target of Lindane is the RDL (Resistance to Dieldrin) subunit of the insect GABA receptor. This receptor is a pentameric ion channel responsible for fast inhibitory transmission.

Mechanism of Blockade

- Normal State: GABA binds to the orthosteric site (extracellular interface). The channel opens, allowing

ions to flow into the neuron. This hyperpolarizes the membrane, inhibiting action potentials. [1]

- **Lindane Action:** Lindane does not compete with GABA at the binding site. Instead, it binds to the picrotoxin (PTX) site located within the transmembrane pore (specifically interacting with 6' Threonine residues in the M2 domain).

- **Result:** The physical occlusion prevents

influx despite the channel being "open." The loss of inhibition causes runaway depolarization, synaptic fatigue, and tetanic convulsions.

Pathway Visualization

The following diagram illustrates the signal transduction failure caused by Lindane.

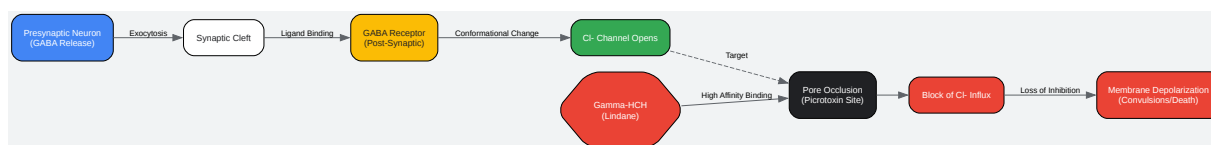

[Click to download full resolution via product page](#)

Figure 1: Signal transduction pathway showing the non-competitive antagonism of the GABA receptor by Gamma-HCH.

Electrophysiological Validation Protocol

To validate the mechanism described above, researchers utilize Whole-Cell Patch-Clamp recording on dissociated insect neurons (e.g., *Periplaneta americana* or *Drosophila* S2 cells expressing RDL).

Experimental Setup

- Rig: Standard patch-clamp amplifier (e.g., Axon MultiClamp).
- Bath Solution: Insect saline (High Na⁺, Low Ca²⁺).
- Pipette Solution: High concentration to establish a driving force for chloride current ().

Step-by-Step Protocol

- Dissection & Dissociation:
 - Isolate thoracic ganglia from the insect.
 - Treat with collagenase/trypsin to dissociate individual somata.
- Giga-seal Formation:
 - Approach neuron with recording pipette (resistance 3-5 M).
 - Apply gentle suction to form a Giga-ohm seal (>1 G).
 - Apply pulse suction to rupture membrane (Whole-cell configuration).
- Voltage Clamp:
 - Clamp membrane potential () at -60 mV.
- Control Recording:
 - Perfuse GABA (

) for 2 seconds.

- Observation: Record inward current (downward deflection) representing influx.
- Antagonist Application:
 - Washout GABA.
 - Pre-incubate with Lindane () for 30 seconds.
 - Co-apply GABA () + Lindane ().
 - Observation: Significant reduction or abolition of the inward current.
- Analysis:
 - Construct a dose-response curve to determine .
 - Validation Criterion: The block should be voltage-independent (characteristic of picrotoxin-site blockers).

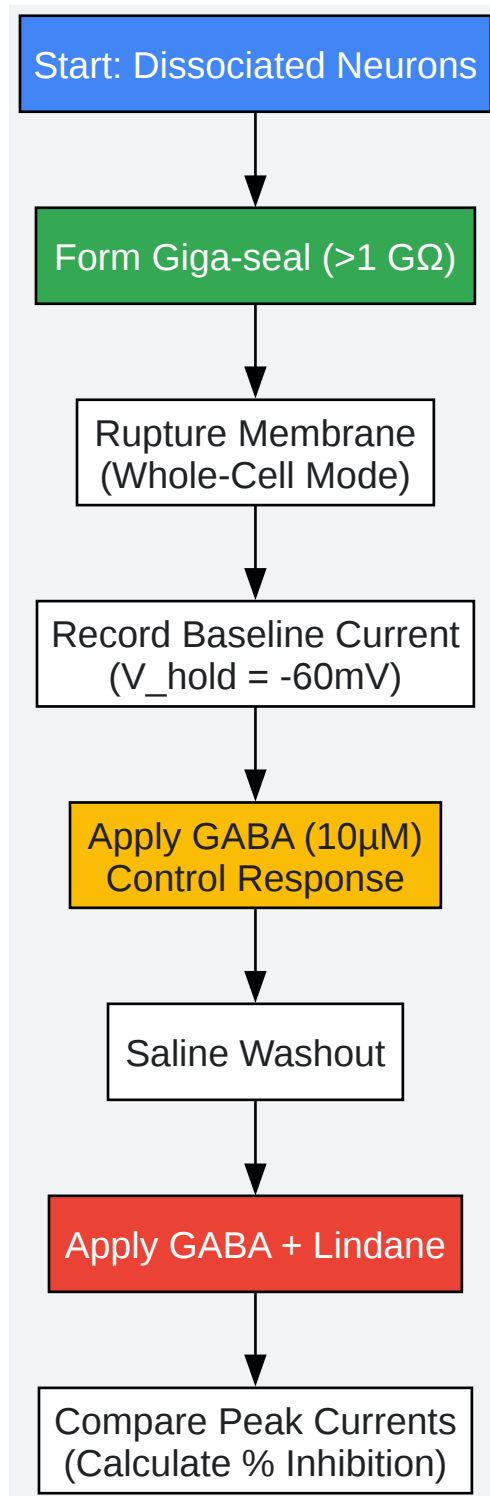

[Click to download full resolution via product page](#)

Figure 2: Workflow for electrophysiological validation of GABA antagonist activity.

Metabolic Fate & Resistance Mechanisms[3]

Resistance to Lindane is widespread and serves as a classic example of Metabolic Resistance. The primary enzyme system involved is the Glutathione S-Transferase (GST) family.[2]

Dehydrochlorination Pathway

Insects resistant to Lindane overexpress specific cytosolic GSTs. These enzymes catalyze the removal of HCl from the Lindane molecule, rendering it unable to bind to the GABA receptor pore.

- Substrate: Gamma-HCH
- Enzyme: Glutathione S-Transferase (GST)[3][4]
- Cofactor: Reduced Glutathione (GSH)
- Primary Metabolite: 1,3,4,5,6-Pentachlorocyclohexene (PCCH) -> Further degradation to chlorobenzenes.

Note: The mutation of the target site (RDL mutation, Ala302 > Ser) is another major resistance mechanism (Target Site Insensitivity), but GST-mediated metabolism is the primary metabolic route.

References

- Narahashi, T. (2002).[5] Nerve membrane ion channels as the target of insecticides.[6] Trends in Pharmacological Sciences.
- Islam, R., & Lynch, J. W. (2012).[7] Mechanism of action of the insecticides, lindane and fipronil, on glycine receptor chloride channels.[7] British Journal of Pharmacology.[7]
- Bloomquist, J. R. (2003). Chloride channels as tools for developing selective insecticides. Archives of Insect Biochemistry and Physiology.
- Casida, J. E., & Durkin, K. A. (2013). Neuroactive insecticides: targets, selectivity, resistance, and secondary effects. Annual Review of Entomology.
- Ffrench-Constant, R. H., et al. (1993). Cyclodiene insecticide resistance: from molecular to population genetics. Annual Review of Entomology.

Need Custom Synthesis?

BenchChem offers custom synthesis for rare earth carbides and specific isotopic labeling.

Email: info@benchchem.com or [Request Quote Online](#).

Sources

- [1. GABA Receptor Physiology and Pharmacology - Basic Neurochemistry - NCBI Bookshelf \[ncbi.nlm.nih.gov\]](#)
- [2. The role of glutathione-S-transferase in anti-cancer drug resistance - PMC \[pmc.ncbi.nlm.nih.gov\]](#)
- [3. Cytochrome P450 and Glutathione S-Transferase Confer Metabolic Resistance to SYP-14288 and Multi-Drug Resistance in Rhizoctonia solani - PMC \[pmc.ncbi.nlm.nih.gov\]](#)
- [4. The role of glutathione S-transferases \(GSTs\) in insecticide resistance in crop pests and disease vectors - PubMed \[pubmed.ncbi.nlm.nih.gov\]](#)
- [5. Mechanism of action of the insecticides, lindane and fipronil, on glycine receptor chloride channels - PMC \[pmc.ncbi.nlm.nih.gov\]](#)
- [6. Lindane but not deltamethrin blocks a component of GABA-activated chloride channels - PubMed \[pubmed.ncbi.nlm.nih.gov\]](#)
- [7. UQ eSpace \[espace.library.uq.edu.au\]](#)
- To cite this document: BenchChem. [Technical Guide: Mechanism of Insecticidal Action of Gamma-HCH (Lindane)]. BenchChem, [2026]. [Online PDF]. Available at: [\[https://www.benchchem.com/product/b172972#mechanism-of-insecticidal-action-of-gamma-hch\]](https://www.benchchem.com/product/b172972#mechanism-of-insecticidal-action-of-gamma-hch)

Disclaimer & Data Validity:

The information provided in this document is for Research Use Only (RUO) and is strictly not intended for diagnostic or therapeutic procedures. While BenchChem strives to provide accurate protocols, we make no warranties, express or implied, regarding the fitness of this product for every specific experimental setup.

Technical Support: The protocols provided are for reference purposes. Unsure if this reagent suits your experiment? [[Contact our Ph.D. Support Team for a compatibility check](#)]

Need Industrial/Bulk Grade? [Request Custom Synthesis Quote](#)

BenchChem

Our mission is to be the trusted global source of essential and advanced chemicals, empowering scientists and researchers to drive progress in science and industry.

Contact

Address: 3281 E Guasti Rd

Ontario, CA 91761, United States

Phone: (601) 213-4426

Email: info@benchchem.com