

Methylene Blue's Neuroprotective Effects: A Mechanistic and Methodological Guide

Author: BenchChem Technical Support Team. **Date:** May 2026

Compound of Interest

Compound Name: Methylene blue

CAS No.: 105504-42-5

Cat. No.: B171794

[Get Quote](#)

Executive Summary

Methylene Blue (MB), a compound with over a century of clinical use, is experiencing a renaissance in neuroscience. Initially synthesized as a textile dye and later used for malaria and methemoglobinemia, its unique biochemical properties position it as a potent neuroprotective agent. This guide provides an in-depth exploration of the core mechanisms driving MB's effects on the central nervous system, focusing on its profound impact on mitochondrial function, redox homeostasis, protein aggregation, and nitric oxide signaling. Designed for researchers and drug development professionals, this document synthesizes established knowledge with practical, field-proven experimental protocols to empower the scientific community to rigorously evaluate and harness the therapeutic potential of this remarkable molecule.

Introduction: The Re-emergence of a "Magic Bullet"

First synthesized in 1876, **Methylene Blue** (methylthioninium chloride) was famously termed a "magic bullet" by Paul Ehrlich for its selective staining of nerve cells and its efficacy against malaria. Its ability to readily cross the blood-brain barrier and accumulate within neurons

underscores its potential for neurological applications.[1][2] While its historical uses are well-documented, recent research has shifted focus to its role in mitigating the pathological processes underlying a host of neurodegenerative disorders, including Alzheimer's and Parkinson's diseases.[1][3][4] This guide delves into the scientific underpinnings of MB's neuroprotective capabilities, moving beyond a simple catalog of effects to explain the causal biochemistry at the heart of its action.

Core Neuroprotective Mechanisms of Action

Methylene Blue's neuroprotective profile is not attributable to a single mode of action but rather to its pleiotropic effects on several key cellular pathways. Its efficacy is notably dose-dependent, exhibiting a hormetic (biphasic) response where low concentrations are beneficial and high concentrations can be detrimental.[5]

The Mitochondrial Nexus: Enhancing Cellular Respiration

The brain's immense energy demand makes it exquisitely vulnerable to mitochondrial dysfunction, a common pathological feature across many neurodegenerative diseases.[1][6] MB directly addresses this vulnerability by acting as an alternative electron carrier in the mitochondrial electron transport chain (ETC).[3][7]

Mechanism of Action: At low concentrations, MB can accept electrons from NADH and bypass Complexes I and III, which are often impaired in disease states.[1][8] It is reduced to its colorless form, leucomethylene blue (LMB or MBH₂), which then donates these electrons directly to Cytochrome c.[1][9] This re-routes electron flow, sustains the proton gradient, and promotes the activity of Complex IV (Cytochrome c oxidase), ultimately increasing oxygen consumption and ATP synthesis.[1][6][10][11] This shunting mechanism not only restores energy production but also reduces the "electron leak" that leads to the formation of damaging reactive oxygen species (ROS).[8][12]

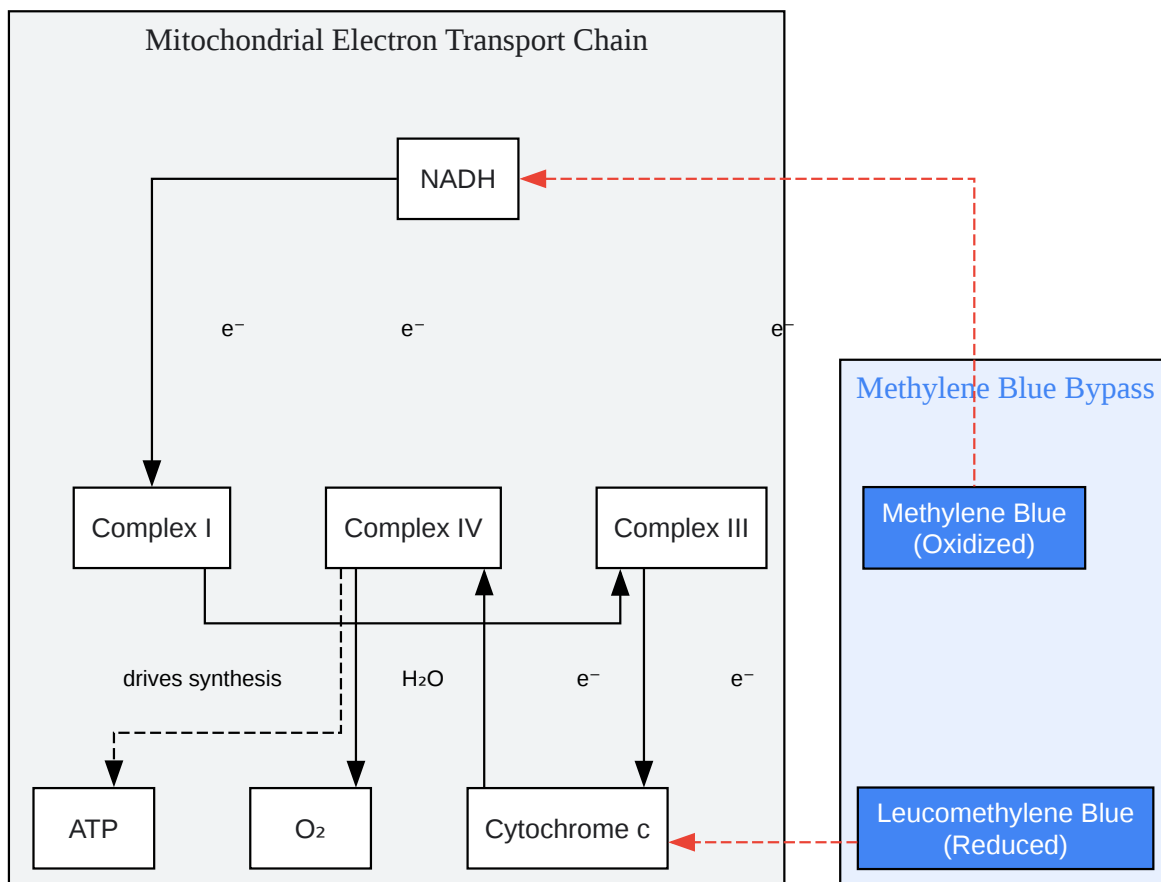

Diagram 1: Methylene Blue as an alternative electron carrier in the ETC.

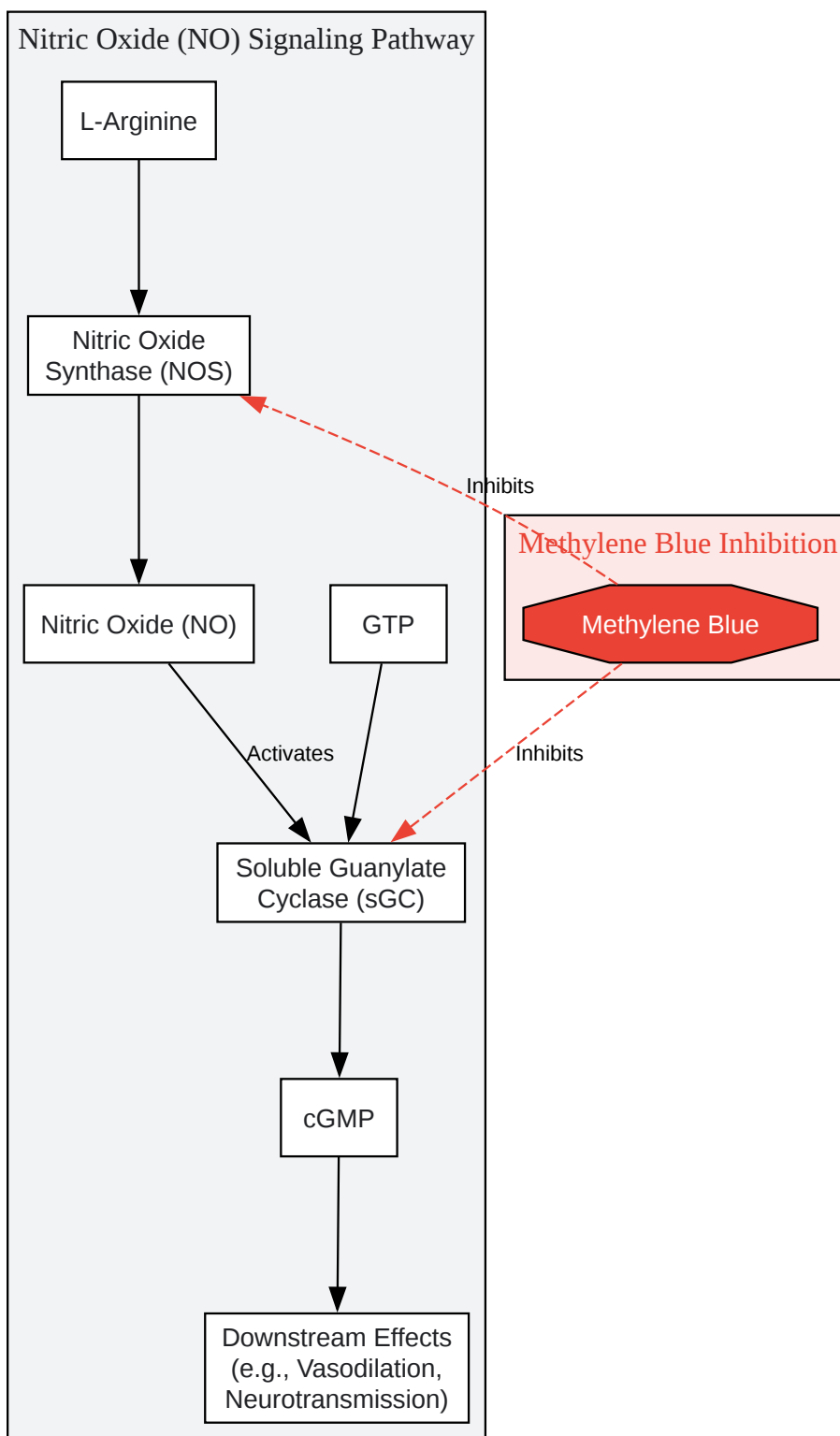

Diagram 2: Methylene Blue's dual inhibition of the NO signaling pathway.

[Click to download full resolution via product page](#)

Caption: **Methylene Blue** inhibits both Nitric Oxide Synthase (NOS) and soluble Guanylate Cyclase (sGC).

Experimental Validation: A Methodological Guide

To ensure scientific rigor, the neuroprotective claims of **Methylene Blue** must be validated through robust, reproducible assays. This section provides step-by-step protocols for key experiments.

Workflow for Assessing Neuroprotection

A typical workflow involves culturing a relevant cell line, inducing a specific form of stress, treating with **Methylene Blue**, and then measuring outcomes related to mitochondrial health, oxidative stress, or protein aggregation.

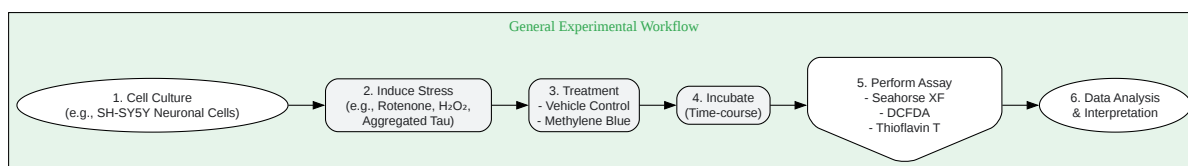

Diagram 3: A generalized workflow for testing the neuroprotective effects of Methylene Blue.

[Click to download full resolution via product page](#)

Caption: A standard workflow for evaluating **Methylene Blue**'s neuroprotective efficacy in vitro.

Protocol: Assessing Mitochondrial Respiration with Seahorse XF

The Agilent Seahorse XF Analyzer is the gold standard for measuring real-time cellular metabolism. [13] This protocol measures the Oxygen Consumption Rate (OCR) as a direct indicator of mitochondrial respiration.

Objective: To determine if **Methylene Blue** can rescue mitochondrial dysfunction induced by a Complex I inhibitor (e.g., rotenone).

Methodology:

- Cell Seeding: Seed a neuronal cell line (e.g., SH-SY5Y) in a Seahorse XF96 cell culture microplate at an optimal density (e.g., 20,000 cells/well) and allow them to adhere overnight. [14]2. Cartridge Hydration: Hydrate a Seahorse XF96 sensor cartridge overnight in a 37°C, non-CO2 incubator using Seahorse XF Calibrant. [14]3. Assay Medium: On the day of the assay, replace the culture medium with pre-warmed Seahorse XF Assay Medium. Incubate the plate in a 37°C, non-CO2 incubator for 30-60 minutes before the run. [14]4. Compound Loading: Load the hydrated sensor cartridge with the compounds to be injected. For a mitochondrial stress test, this typically includes:
 - Port A: Vehicle or **Methylene Blue** (e.g., 100 nM final concentration) + Rotenone (e.g., 1 μM).
 - Port B: Oligomycin (ATP synthase inhibitor).
 - Port C: FCCP (uncoupling agent).
 - Port D: Rotenone/Antimycin A (Complex I/III inhibitors to shut down respiration).
- Seahorse XF Run: Calibrate the sensor cartridge and run the assay. The machine will measure baseline OCR, then inject the compounds from each port sequentially, measuring the OCR after each injection.
- Data Analysis: Analyze the resulting OCR data to determine basal respiration, ATP-linked respiration, maximal respiration, and spare respiratory capacity. Compare the effects of MB + Rotenone to Rotenone alone.

Parameter	Expected Outcome with Rotenone	Expected Outcome with Rotenone + Methylene Blue
Basal OCR	Significantly Decreased	Partially or Fully Restored
ATP Production	Significantly Decreased	Partially or Fully Restored
Maximal Respiration	Significantly Decreased	Partially or Fully Restored

Table 1: Expected outcomes from a Seahorse XF Mito Stress Test.

Protocol: Quantifying Reactive Oxygen Species (ROS) with DCFDA

The 2',7'-dichlorodihydrofluorescein diacetate (H2DCFDA) assay is a common method for measuring intracellular ROS. [15][16] Objective: To determine if **Methylene Blue** reduces intracellular ROS levels under conditions of oxidative stress.

Methodology:

- Cell Culture: Seed cells in a dark, clear-bottomed 96-well plate and culture overnight. [15]2. Induce Stress: Treat cells with a ROS-inducing agent (e.g., H₂O₂) with or without co-treatment of **Methylene Blue** for a designated time (e.g., 1-2 hours). [16]3. Loading: Wash the cells with a buffer (e.g., PBS). Add a working solution of H2DCFDA (e.g., 20 μM) to each well. [15][16]4. Incubation: Incubate the plate in the dark at 37°C for 30-45 minutes. [15]During this time, intracellular esterases cleave the acetate groups, and ROS oxidizes the probe to the highly fluorescent 2',7'-dichlorofluorescein (DCF).
- Measurement: Measure the fluorescence intensity using a microplate reader with an excitation wavelength of ~485 nm and an emission wavelength of ~530 nm. [17]6. Normalization: After reading, you can lyse the cells and perform a protein assay (e.g., Bradford) to normalize the fluorescence signal to the cell number. [17]

Protocol: Monitoring Tau Aggregation with Thioflavin T (ThT)

The Thioflavin T (ThT) assay is a widely used method to monitor the formation of amyloid-like fibrils in vitro. [18] Objective: To determine if **Methylene Blue** inhibits the heparin-induced aggregation of recombinant tau protein.

Methodology:

- Reaction Setup: In a 96-well non-binding black plate, set up aggregation reactions containing:
 - Recombinant tau protein (e.g., 10 μ M). [19] * An aggregation inducer (e.g., heparin, 0.06 mg/ml). [20][19] * Thioflavin T (e.g., 10-25 μ M). [19][21][18] * Varying concentrations of **Methylene Blue** or vehicle control.
- Incubation: Seal the plate and incubate at 37°C with shaking. [18]3. Measurement: Measure fluorescence at regular intervals (e.g., every hour for 24-72 hours) using an excitation wavelength of ~450 nm and an emission wavelength of ~485-510 nm. [21][18]4. Data Analysis: Plot fluorescence intensity versus time. A sigmoidal curve indicates fibril formation. A reduction in the fluorescence plateau or a lag in the aggregation kinetics in the presence of **Methylene Blue** indicates an inhibitory effect. [20]

Therapeutic Considerations and Future Directions

While the preclinical evidence for **Methylene Blue's** neuroprotective effects is compelling, its translation to the clinic has faced challenges. [20][22] Issues such as the difficulty in blinding clinical trials due to MB's color and its complex, hormetic dose-response curve require careful consideration. [5][22] Derivatives like leuco-methylthionium (LMTM) have been developed to improve bioavailability and tolerability. [23][24] Future research should focus on:

- Optimizing Dosing: Elucidating the precise therapeutic window for different neurodegenerative conditions.
- Biomarker Development: Identifying reliable biomarkers to track MB's engagement with its targets in the CNS.
- Combination Therapies: Exploring synergistic effects of MB with other neuroprotective agents.

Methylene Blue stands as a testament to the enduring value of reinvestigating established drugs with modern tools. Its multifaceted mechanisms of action make it a uniquely promising candidate for combating the complex pathology of neurodegenerative diseases.

References

- Akihiko, T., et al. (2019). **Methylene Blue** Inhibits Formation of Tau Fibrils but not of Granular Tau Oligomers: A Plausible Key to Understanding Failure of a Clinical Trial for Alzheimer's Disease. *Journal of Alzheimer's Disease*.
- Yang, L., et al. (2021). From Mitochondrial Function to Neuroprotection – An Emerging Role for **Methylene Blue**.
- Bužga, M., et al. (2022). Molecular Mechanisms of the Neuroprotective Effect of **Methylene Blue**.
- Yang, L., et al. (2016). Alternative Mitochondrial Electron Transfer for the Treatment of Neurodegenerative Diseases and Cancers: **Methylene Blue** Connects the Dots. *Progress in Neurobiology*.
- Renoja Wellness. (2025). **Methylene Blue** And Its Impact On Mitochondrial Function, A Deep Dive. Renoja Wellness.
- Poteet, E., et al. (2012).
- Rojas, J. C., et al. (2012). Neurometabolic mechanisms for memory enhancement and neuroprotection of **methylene blue**. *Progress in Neurobiology*.
- AgelessRx.
- Sadoun, A., et al. (2023). Targeting mitochondrial dysfunction using **methylene blue** or mitoquinone to improve skeletal aging. *GeroScience*.
- Gonzalez-Lima, F., et al. (2014). Protection against neurodegeneration with low-dose **methylene blue** and near-infrared light. *Frontiers in Cellular Neuroscience*.
- Michigan Compounding Pharmacy. (2023). **Methylene Blue** & Improving Mitochondrial Function. Michigan Compounding Pharmacy.
- ResearchGate. (n.d.). Neuroprotection with **methylene blue**.
- Alzheimer's Drug Discovery Foundation. (2024). **Methylene blue** (and TRx0237). ADDF.
- Alzforum. (2015). Et Tu, **Methylene Blue**? Drug Only Works as Prophylactic. Alzforum.
- Oz, M., et al. (2011). **Methylene blue** and Alzheimer's disease. *Biochemical Pharmacology*.
- Rehman, H., et al. (2023). Exploring **Methylene Blue** and Its Derivatives in Alzheimer's Treatment: A Comprehensive Review of Randomized Control Trials. *Cureus*.
- Pan, P., et al. (2019). Effects of **methylene blue** on the nitric oxide-soluble guanylate cyclase-cyclic guanylyl monophosphate pathway and cytokine levels in rats with sepsis. *International Journal of Clinical and Experimental Medicine*.

- Mayer, B., et al. (1993). Inhibition of nitric oxide synthesis by **methylene blue**. *Biochemical Pharmacology*.
- ResearchGate. (n.d.). Inhibition of Tau aggregation by **methylene blue** (MB) determined by the filter assay.
- Rehman, H., et al. (2023). Exploring **Methylene Blue** and Its Derivatives in Alzheimer's Treatment: A Comprehensive Review of Randomized Control Trials. *Cureus*.
- Alzforum. (n.d.). HMTM. Alzforum.
- Gauthier, S., et al. (2022). Clinical effectiveness and prospects of **methylene blue**: A systematic review. *Journal of Clinical Medicine*.
- Dr. Oracle. (2025). Does **methylene blue** affect nitric oxide (NO) production?. Dr. Oracle.
- Diva-portal.org. Nitric Oxide Inhibition by **Methylene Blue** in the Treatment of Neuropathic Pain : A preliminary report. Diva-portal.org.
- The Pod of Inquiry. (2023). **Methylene Blue** and Nitric Oxide. The Pod of Inquiry.
- Xue, H., et al. (2021). The Potentials of **Methylene Blue** as an Anti-Aging Drug. *Cells*.
- ResearchGate. (n.d.). The structure and the redox cycle of **methylene blue**.
- Atamna, H., et al. (2008).
- StressMarq Biosciences Inc. (n.d.). Tau Protein Thioflavin T Assay. StressMarq Biosciences Inc..
- YouTube. (2024). Why I Take **Methylene Blue** (And Why You Might Want To As Well). YouTube.
- Crowe, A., et al. (2013).
- ResearchGate. (n.d.). **Methylene Blue** Inhibits Formation of Tau Fibrils but not of Granular Tau Oligomers: A Plausible Key to Understanding Failure of a Clinical Trial for Alzheimer's Disease.
- Seo, D. H., et al. (2023). Investigating the hidden mechanism underlying the tau interaction by **methylene blue**. *bioRxiv*.
- Hello Bio. (n.d.). DCFDA / H2DCFDA - Cellular ROS Assay Kit Protocol. Hello Bio.
- Earl, J., et al. (2021).
- Agilent. (n.d.).
- ResearchGate. (2020). What is the exact protocol of ROS measurement using DCFDA?.
- Agilent. (n.d.).
- Uzhytchak, M., et al. (2024). **Methylene blue** and its potential in the treatment of traumatic brain injury, brain ischemia, and Alzheimer's disease.
- Weill Cornell Medicine. (n.d.). User Guide: Agilent Seahorse Units (B38 Weill). Weill Cornell Medicine.
- Cayman Chemical. (2017). ROS Detection Cell-Based Assay Kit (DCFDA). Cayman Chemical.
- National Center for Biotechnology Information. (2020).

- National Center for Biotechnology Information. (2024). Protocol for evaluating mitochondrial respiration in iPSC-derived neurons by the Seahorse XF analyzer. NCBI.

Need Custom Synthesis?

BenchChem offers custom synthesis for rare earth carbides and specific isotopic labeling.

Email: info@benchchem.com or [Request Quote Online](#).

Sources

- 1. From Mitochondrial Function to Neuroprotection – An Emerging Role for Methylene Blue - PMC [[pmc.ncbi.nlm.nih.gov](https://pubmed.ncbi.nlm.nih.gov)]
- 2. Frontiers | Protection against neurodegeneration with low-dose methylene blue and near-infrared light [frontiersin.org]
- 3. Molecular Mechanisms of the Neuroprotective Effect of Methylene Blue - PubMed [pubmed.ncbi.nlm.nih.gov]
- 4. Methylene blue and its potential in the treatment of traumatic brain injury, brain ischemia, and Alzheimer's disease - PubMed [pubmed.ncbi.nlm.nih.gov]
- 5. Neurometabolic mechanisms for memory enhancement and neuroprotection of methylene blue - PMC [[pmc.ncbi.nlm.nih.gov](https://pubmed.ncbi.nlm.nih.gov)]
- 6. hdrx.com [hdrx.com]
- 7. Alternative Mitochondrial Electron Transfer for the Treatment of Neurodegenerative Diseases and Cancers: Methylene Blue Connects the Dots - PMC [[pmc.ncbi.nlm.nih.gov](https://pubmed.ncbi.nlm.nih.gov)]
- 8. Neuroprotective Actions of Methylene Blue and Its Derivatives | PLOS One [journals.plos.org]
- 9. The Potentials of Methylene Blue as an Anti-Aging Drug - PMC [[pmc.ncbi.nlm.nih.gov](https://pubmed.ncbi.nlm.nih.gov)]
- 10. Methylene Blue And Its Impact On Mitochondrial Function, A Deep Dive - Renoja [renoja.com]
- 11. Methylene blue delays cellular senescence and enhances key mitochondrial biochemical pathways - PubMed [pubmed.ncbi.nlm.nih.gov]
- 12. Targeting mitochondrial dysfunction using methylene blue or mitoquinone to improve skeletal aging - PMC [[pmc.ncbi.nlm.nih.gov](https://pubmed.ncbi.nlm.nih.gov)]
- 13. agilent.com [agilent.com]

- [14. tabaslab.com \[tabaslab.com\]](#)
- [15. DCFDA / H2DCFDA - Cellular ROS Assay Kit Protocol \[hellobio.com\]](#)
- [16. A Simple Microplate Assay for Reactive Oxygen Species Generation and Rapid Cellular Protein Normalization - PMC \[pmc.ncbi.nlm.nih.gov\]](#)
- [17. Detection of Total Reactive Oxygen Species in Adherent Cells by 2',7'-Dichlorodihydrofluorescein Diacetate Staining - PMC \[pmc.ncbi.nlm.nih.gov\]](#)
- [18. Tau Protein Thioflavin T Assay | StressMarq | StressMarq Biosciences Inc. \[stressmarq.com\]](#)
- [19. researchgate.net \[researchgate.net\]](#)
- [20. Methylene Blue Inhibits Formation of Tau Fibrils but not of Granular Tau Oligomers: A Plausible Key to Understanding Failure of a Clinical Trial for Alzheimer's Disease - PubMed \[pubmed.ncbi.nlm.nih.gov\]](#)
- [21. Aminothienopyridazines and Methylene Blue Affect Tau Fibrillization via Cysteine Oxidation - PMC \[pmc.ncbi.nlm.nih.gov\]](#)
- [22. alzdiscovery.org \[alzdiscovery.org\]](#)
- [23. alzforum.org \[alzforum.org\]](#)
- [24. pfm :: Precision and Future Medicine \[pfmjournals.org\]](#)
- [To cite this document: BenchChem. \[Methylene Blue's Neuroprotective Effects: A Mechanistic and Methodological Guide\]. BenchChem, \[2026\]. \[Online PDF\]. Available at: \[https://www.benchchem.com/product/b171794/docs#methylene-blue-s-neuroprotective-effects-a-mechanistic-and-methodological-guide\]](#)

Disclaimer & Data Validity:

The information provided in this document is for Research Use Only (RUO) and is strictly not intended for diagnostic or therapeutic procedures. While BenchChem strives to provide accurate protocols, we make no warranties, express or implied, regarding the fitness of this product for every specific experimental setup.

Technical Support: The protocols provided are for reference purposes. Unsure if this reagent suits your experiment?

Need Industrial/Bulk Grade? [Request Custom Synthesis Quote](#)

BenchChem

Our mission is to be the trusted global source of essential and advanced chemicals, empowering scientists and researchers to drive progress in science and industry.

Contact

Address: 3281 E Guasti Rd

Ontario, CA 91761, United States

Phone: (601) 213-4426

Email: info@benchchem.com

[Contact our Ph.D. Support Team for a compatibility check](#)