

Application Note: Enzymatic Inhibition Studies Using Selenium-Modified Nucleobases

Author: BenchChem Technical Support Team. **Date:** May 2026

Compound of Interest

Compound Name: *1H-Pyrimidine-2,4-diselone*

CAS No.: 10443-86-4

Cat. No.: B170428

[Get Quote](#)

Executive Summary

Selenium-modified nucleobases (Se-nucleobases) represent a frontier in "atom-specific mutagenesis." By replacing a specific oxygen atom (e.g., 2-position of thymidine or 6-position of guanosine) with selenium, researchers can introduce a "soft," polarizable, and anomalously scattering atom without significantly disrupting the global Watson-Crick base-pairing architecture.

This guide details the methodology for using Se-nucleobases as mechanistic probes to study enzymatic inhibition. Unlike gross structural alterations, Se-modification offers a subtle perturbation—altering electronic distribution and van der Waals radii—to dissect the steric and electronic requirements of enzyme active sites. This application note covers the handling of labile Se-compounds, steady-state kinetic assays, and structural validation via X-ray crystallography.

Scientific Foundation: The Selenium Advantage[1] Mechanism of Action

The substitution of Oxygen (O) with Selenium (Se) introduces specific physicochemical changes that can be exploited for inhibition studies:

- **Steric Perturbation:** The van der Waals radius of Se (1.90 Å) is larger than O (1.52 Å). In tightly packed active sites (e.g., DNA polymerases or methyltransferases), this ~0.4 Å difference can induce a "steric clash," stalling the catalytic cycle without preventing initial binding.
- **Electronic Modulation:** Se is less electronegative than O, making it a poorer hydrogen bond acceptor but a better chalcogen bond donor. This can weaken key catalytic hydrogen bond networks required for transition state stabilization.
- **Nuclease Resistance:** Se-modification at the 2'-position or nucleobase often renders the oligonucleotide resistant to hydrolytic cleavage by nucleases, acting as a competitive inhibitor of degradation.

Diagram: Mechanism of Inhibition

The following diagram illustrates the bifurcation between a natural substrate and a Se-modified inhibitor within an enzymatic pathway.

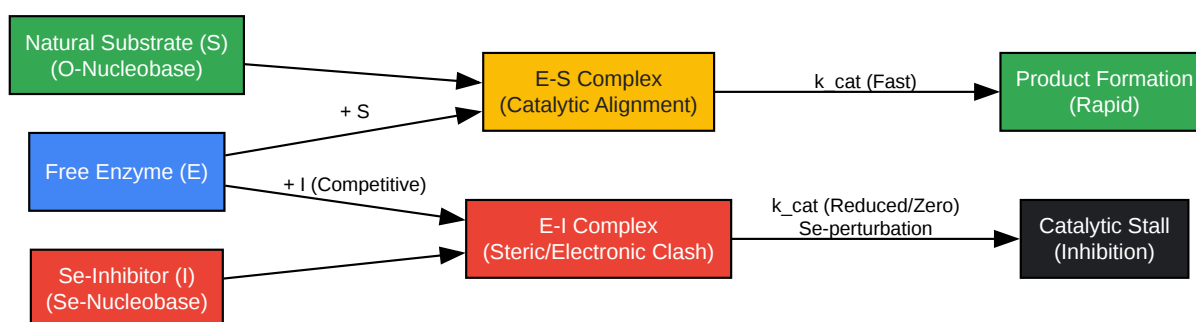

[Click to download full resolution via product page](#)

Caption: Kinetic bifurcation showing how Se-modification allows enzyme binding (E-I Complex) but impedes the catalytic step due to atomic radius expansion or electronic mismatch.

Protocol A: Critical Handling & Preparation (Self-Validating System)

Context: Selenium-modified nucleosides are prone to oxidation (forming selenium oxides) and elimination reactions (loss of Se) if mishandled. A compromised stock solution invalidates all downstream kinetic data.

Reagents Required:

- Se-Nucleoside/Nucleotide Stock: (e.g., 5-Se-TTP, 2-Se-UTP).
- Reducing Agent: DTT (Dithiothreitol) or TCEP (Tris(2-carboxyethyl)phosphine).
- Buffer: Degassed Tris-HCl or HEPES (pH 7.0–8.0). Avoid phosphate buffers if analyzing phosphate-dependent kinetics to reduce background.

Step-by-Step Methodology:

- Degassing: Degas all buffers using a vacuum manifold or by bubbling with Argon gas for 20 minutes. Oxygen is the primary enemy of Se-stability.
- Stock Preparation: Dissolve the Se-nucleotide in the degassed buffer containing 1–5 mM DTT.
 - Expert Insight: DTT prevents the oxidation of the selenium atom. If the solution turns yellow/orange, selenium has likely oxidized or eliminated (elemental Se precipitates).
- Purity Check (Validation Step):
 - Run a reverse-phase HPLC (C18 column) immediately before the kinetic assay.
 - Mobile Phase: 0-20% Acetonitrile in 20 mM Triethylammonium acetate (TEAA).
 - Detection: Monitor UV absorbance. Se-nucleobases typically exhibit a red-shift in (e.g., ~300–360 nm) compared to their oxygen counterparts (~260 nm).
 - Pass Criteria: >95% purity with characteristic red-shifted UV peak.^[1]

Protocol B: Steady-State Kinetic Characterization

Context: This protocol determines the inhibition constant (

) and mode of inhibition (competitive, non-competitive) for a DNA Polymerase using a Se-TTP analog.

Experimental Setup:

- Enzyme: DNA Polymerase (e.g., Klenow fragment, T7 DNA pol).
- Template: Primer-template duplex requiring Thymidine incorporation.
- Substrate: Natural dTTP (variable concentration).
- Inhibitor: 2-Se-dTTP (fixed concentrations: 0, 0.5x, 1x, 2x estimated).
- Detection: Fluorescence (using a molecular beacon or intercalating dye like PicoGreen) or Radiometric (-dATP incorporation).

Workflow:

- Master Mix: Prepare reaction buffer (50 mM Tris pH 7.5, 10 mM MgCl₂, 1 mM DTT).
- Incubation:
 - Mix Enzyme + DNA Template.
 - Add Se-Inhibitor (2-Se-dTTP) and incubate for 2 minutes to allow equilibrium binding.
- Initiation: Add natural dTTP to start the reaction.
- Quenching: At defined time points (e.g., 10, 20, 30 sec), quench with 0.5 M EDTA.
- Analysis: Measure product formation.

Data Analysis (The "Expertise" Pillar):

Do not rely solely on

. Use the Lineweaver-Burk or Hanes-Woolf plots to determine the mechanism.

- Competitive Inhibition: Lines intersect at the Y-axis (

is unchanged, apparent

increases). Most common for Se-nucleobases.

- Steric Stall: If the Se-nucleotide is incorporated but prevents extension (chain termination), this will manifest as a burst phase followed by a plateau.

Table 1: Expected Kinetic Parameters (Example: Polymerase Incorporation)

Parameter	Natural Substrate (O)	Se-Modified (Se)	Interpretation
(Binding Affinity)	~1–5 M	~1–10 M	Se-base usually retains Watson-Crick pairing; is often similar.
(Turnover)	High	Significantly Lower	Steric clash of Se prevents transition state geometry.
(Efficiency)	100% (Reference)	<10%	Se-nucleobase acts as a "kinetic jammer."
UV	260 nm	~290–360 nm	Diagnostic red-shift confirming Se presence.

Protocol C: Structural Validation (X-Ray Crystallography)

Context: To authoritatively claim why inhibition occurs, you must solve the crystal structure. Se-nucleobases facilitate this by providing anomalous scattering signals for phasing (MAD/SAD), killing two birds with one stone: structure solution and inhibitor mapping.

Workflow Diagram

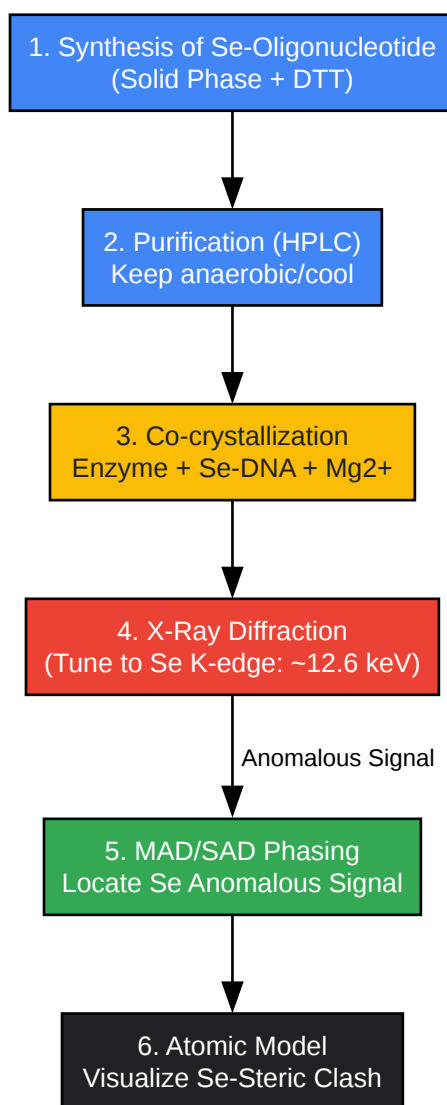

[Click to download full resolution via product page](#)

Caption: Structural biology workflow utilizing Se-nucleic acids for simultaneous phase determination and active-site mapping.

Key Steps for Se-Crystallography:

- Crystallization: Use standard screens (Hampton, Emerald) but include 1–5 mM TCEP in the mother liquor to prevent Se oxidation during the weeks-long crystallization process.
- Data Collection:
 - Perform a fluorescence scan at the synchrotron to locate the Selenium K-edge (approx. 12.658 keV or 0.9795 Å).
 - Collect data at the peak wavelength to maximize the anomalous signal.
- Refinement:
 - Se is a heavy atom (34 electrons). In the electron density map, the Se atom will appear as a massive peak compared to Oxygen.
 - Validation: If the Se peak is located exactly where the Oxygen would be in the natural substrate, but the surrounding protein residues (e.g., an active site Tyrosine or Arginine) are displaced, you have structural proof of the steric inhibition mechanism.

Troubleshooting & Optimization

Issue	Probable Cause	Corrective Action
Yellowing of Solution	Oxidation of Se to Se-oxide or elemental Se.	Discard. Prepare fresh stock with higher [DTT] and degassed water.
No Inhibition Observed	Se-modification position is tolerated by enzyme.	Move Se to a different position (e.g., from 2-Se-T to 4-Se-T) to target specific active site residues.
Crystal Degradation	Radiation damage to Se-C bond.	Collect data at 100 K. Use a "dose-efficient" strategy; Se bonds can break under high X-ray flux.

References

- Huang, Z., & Szostak, J. W. (2003). Evolution of aptamers with a new base-pair packing motif. *RNA*, 9(12), 1456–1463. [Link](#)
- Sheng, J., & Huang, Z. (2010). Selenium Derivatization of Nucleic Acids for X-ray Crystal Structure and Function Studies.[2] *Chemistry & Biodiversity*, 7(4), 753–785.[2] [Link](#)
- Salon, J., et al. (2008). Derivatization of DNAs with selenium at 6-position of guanine for function and crystal structure studies. *Nucleic Acids Research*, 36(22), 7009–7018. [Link](#)
- Sun, H., Jiang, S., & Huang, Z. (2015). Nucleic Acid Crystallography via Direct Selenium Derivatization: RNAs Modified with Se-Nucleobases. *Methods in Molecular Biology*, 1320, 193-204.[3] [Link](#)
- Egli, M., et al. (2002). Crystal structure of a DNA duplex containing a 2'-selenium-labeled uridine. *Journal of the American Chemical Society*, 124(49), 14910-14916. [Link](#)

Need Custom Synthesis?

BenchChem offers custom synthesis for rare earth carbides and specific isotopic labeling.

Email: info@benchchem.com or [Request Quote Online](#).

Sources

- 1. academic.oup.com [academic.oup.com]
- 2. Selenium derivatization of nucleic acids for X-ray crystal-structure and function studies - PubMed [pubmed.ncbi.nlm.nih.gov]
- 3. Nucleic Acid Crystallography via Direct Selenium Derivatization: RNAs Modified with Se-Nucleobases - PubMed [pubmed.ncbi.nlm.nih.gov]
- To cite this document: BenchChem. [Application Note: Enzymatic Inhibition Studies Using Selenium-Modified Nucleobases]. BenchChem, [2026]. [Online PDF]. Available at: [<https://www.benchchem.com/product/b170428/docs#application-note-enzymatic-inhibition-studies-using-selenium-modified-nucleobases>]

Disclaimer & Data Validity:

The information provided in this document is for Research Use Only (RUO) and is strictly not intended for diagnostic or therapeutic procedures. While BenchChem strives to provide accurate protocols, we make no warranties, express or implied, regarding the fitness of this product for every specific experimental setup.

Technical Support: The protocols provided are for reference purposes. Unsure if this reagent suits your experiment?

Need Industrial/Bulk Grade? [Request Custom Synthesis Quote](#)

BenchChem

Our mission is to be the trusted global source of essential and advanced chemicals, empowering scientists and researchers to drive progress in science and industry.

Contact

Address: 3281 E Guasti Rd
Ontario, CA 91761, United States
Phone: (601) 213-4426
Email: info@benchchem.com

[Contact our Ph.D. Support Team for a compatibility check](#)