

Technical Guide: Spectroscopic Analysis & Forensic Identification of 4-Methoxyphenylacetone

Author: BenchChem Technical Support Team. **Date:** May 2026

Compound of Interest

Compound Name:	4-Methoxyphenylacetone
CAS No.:	122-84-9
Cat. No.:	B017817

[Get Quote](#)

Executive Summary

4-Methoxyphenylacetone (4-MeO-P2P; CAS 122-84-9) is a critical substituted propiophenone derivative used legitimately in organic synthesis and illicitly as a primary precursor for the controlled substances PMA (paramethoxyamphetamine) and PMMA (paramethoxymethamphetamine).

This technical guide provides a rigorous framework for the spectroscopic characterization of 4-MeO-P2P. It focuses on distinguishing the para-isomer from its regioisomers (2- and 3-methoxy) and establishing a self-validating analytical workflow for forensic and quality control (QC) applications.

Part 1: Chemical Profile & Structural Logic

Understanding the electronic environment of 4-MeO-P2P is prerequisite to interpreting its spectral data. The molecule consists of a phenyl ring substituted at the para position with an electron-donating methoxy group (-OCH

) and a 2-oxopropyl side chain.

Parameter	Data
IUPAC Name	1-(4-Methoxyphenyl)propan-2-one
Formula	C
	H
	O
Molecular Weight	164.20 g/mol
Key Functionality	Ketone (C=O), Aryl Ether (Ar-O-C)
Electronic Effect	Methoxy group acts as a -donor, shielding ortho/para protons (NMR) and stabilizing benzylic carbocations (MS).

Part 2: Mass Spectrometry (MS) Analysis[1]

Mass spectrometry provides the primary "fingerprint" for identification. The fragmentation of 4-MeO-P2P is dominated by benzylic cleavage rather than the McLafferty rearrangement, due to the high stability of the resulting resonance-stabilized cation.

Fragmentation Pathway Logic

- Molecular Ion (M^+): Observed at m/z 164. Usually of moderate intensity.
- α -Cleavage (Base Peak): The bond between the carbonyl carbon and the benzylic carbon is cleaved (or the bond between carbonyl and methyl). However, the dominant pathway is the formation of the 4-methoxybenzyl cation (tropylium analog).
 - (m/z 164)
Loss of Acetyl radical [$CH_3CO\cdot$]
 $M^+ - COCH_3$

] (mass 43)

m/z 121.

- Secondary Fragmentation: The stable m/z 121 ion further degrades by losing formaldehyde (CH₂O) or CO to form m/z 91 or m/z 77.

Visualization: Fragmentation Mechanism

The following diagram illustrates the ionization and subsequent dissociation pathways.

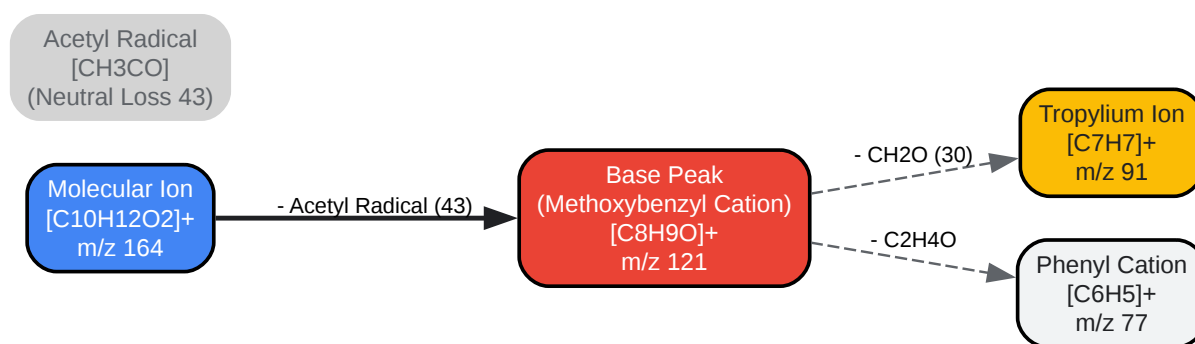

[Click to download full resolution via product page](#)

Caption: Primary electron ionization (EI) fragmentation pathway of **4-Methoxyphenylacetone** showing the dominant m/z 121 base peak.[1]

Part 3: Nuclear Magnetic Resonance (NMR) Spectroscopy

NMR is the definitive tool for distinguishing the para-isomer from ortho and meta isomers. The symmetry of the para-substitution creates a characteristic AA'BB' splitting pattern in the aromatic region.

H NMR Data (400 MHz, CDCl₃)

Shift (ppm)	Multiplicity	Integration	Assignment	Structural Logic
2.13	Singlet (s)	3H	-C(=O)CH	Terminal methyl group adjacent to carbonyl (deshielded).
3.64	Singlet (s)	2H	Ar-CH -C=O	Benzylic protons. Singlet indicates no adjacent protons on the chain.
3.80	Singlet (s)	3H	-OCH	Methoxy protons. Highly deshielded by oxygen.
6.87	Doublet (d)	2H	Ar-H (3,5)	Ortho to methoxy group. Shielded by resonance donation.
7.11	Doublet (d)	2H	Ar-H (2,6)	Meta to methoxy group. Less shielded.

*Note: While often reported as doublets, this is formally an AA'BB' system (Hz), characteristic of 1,4-disubstitution.

C NMR Data (100 MHz, CDCl)

Shift (ppm)	Assignment
29.1	Terminal Methyl (-CH ₃)
50.2	Benzylic Carbon (-CH ₂ -)
55.3	Methoxy Carbon (-OCH ₃)
114.2	Aromatic C-3, C-5 (Ortho to OMe)
126.5	Aromatic C-1 (Quaternary, attached to CH ₂)
130.5	Aromatic C-2, C-6 (Meta to OMe)
158.7	Aromatic C-4 (Quaternary, attached to OMe)
206.8	Carbonyl Carbon (C=O)

Part 4: Infrared (IR) Spectroscopy[3][4]

IR is useful for quick functional group verification but less specific for isomer differentiation than NMR.

- 1710–1715 cm⁻¹

: Strong C=O stretch (saturated ketone). This distinguishes it from conjugated ketones (which would appear lower, ~1680 cm⁻¹).

).

- 1245–1250 cm⁻¹

: Strong C-O-C asymmetric stretch (aryl alkyl ether).

- 810–840 cm

: C-H out-of-plane bending. A strong band here is indicative of para-disubstituted benzene rings.

Part 5: Experimental Protocol (Analytical)

Protocol: GC-MS Identification & Isomer Differentiation

This protocol validates the identity of 4-MeO-P2P and separates it from its ortho (2-MeO) and meta (3-MeO) isomers.

Reagents:

- Sample (dissolved in Methanol or Ethyl Acetate).
- Internal Standard (e.g., Diphenylmethane or Tetradecane).

Instrument Parameters (Agilent 7890/5977 or equivalent):

- Column: DB-5MS or HP-5MS (30m

0.25mm

0.25

m).

- Why: Non-polar phases separate based on boiling point and polarity. The para isomer typically has the highest boiling point due to symmetry/packing.
- Inlet: Split mode (20:1), 250°C.
- Carrier Gas: Helium, 1.0 mL/min (constant flow).
- Oven Program:
 - Initial: 80°C (hold 1 min).
 - Ramp: 15°C/min to 280°C.

- Hold: 3 min.
- MS Source: EI mode (70 eV), 230°C. Scan range 40–400 amu.

Elution Order Logic: On a 5% phenyl-methylpolysiloxane column (DB-5), the elution order is typically:

- 2-Methoxyphenylacetone (Ortho): Lowest retention time (steric hindrance reduces intermolecular forces).
- 3-Methoxyphenylacetone (Meta): Intermediate.
- **4-Methoxyphenylacetone (Para):** Highest retention time (highest symmetry/polarity interaction).

Workflow Visualization

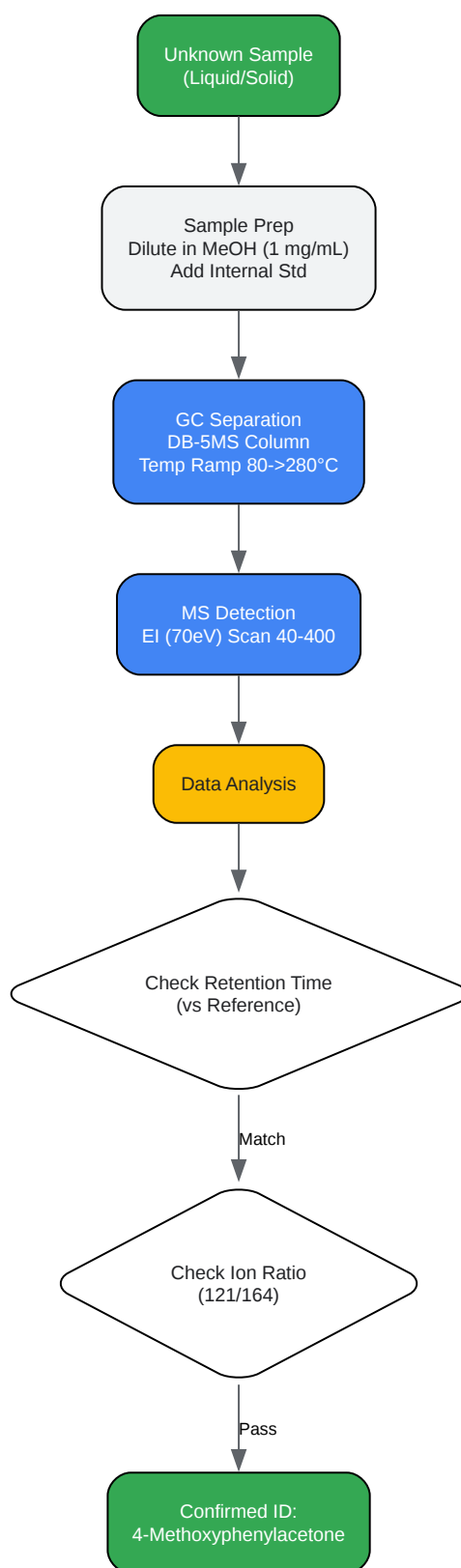

[Click to download full resolution via product page](#)

Caption: Standardized GC-MS analytical workflow for forensic identification.

References

- National Center for Biotechnology Information (PubChem). **4-Methoxyphenylacetone** (Compound). PubChem CID 31231. Available at: [\[Link\]](#)
- Kranenburg, R. F., et al. (2019).^[2] Distinguishing drug isomers in the forensic laboratory: GC-VUV in addition to GC-MS. Forensic Science International.^[3]^[4] Available at: [\[Link\]](#)
- NIST Mass Spectrometry Data Center. 1-(4-Methoxyphenyl)-2-propanone Mass Spectrum. NIST Chemistry WebBook, SRD 69. Available at: [\[Link\]](#)
- United Nations Office on Drugs and Crime (UNODC). Recommended Methods for the Identification and Analysis of Amphetamine, Methamphetamine and their Ring-Substituted Analogues in Seized Materials. (Specifically referencing precursor analysis sections). Available at: [\[Link\]](#)

Need Custom Synthesis?

BenchChem offers custom synthesis for rare earth carbides and specific isotopic labeling.

Email: info@benchchem.com or [Request Quote Online](#).

Sources

- 1. [researchgate.net](https://www.researchgate.net) [[researchgate.net](https://www.researchgate.net)]
- 2. pure.uva.nl [pure.uva.nl]
- 3. [semanticscholar.org](https://www.semanticscholar.org) [[semanticscholar.org](https://www.semanticscholar.org)]
- 4. VUV Analytics [[vuvanalytics.com](https://www.vuvanalytics.com)]
- To cite this document: BenchChem. [Technical Guide: Spectroscopic Analysis & Forensic Identification of 4-Methoxyphenylacetone]. BenchChem, [2026]. [Online PDF]. Available at: [<https://www.benchchem.com/product/b017817/docs#technical-guide-spectroscopic-analysis-forensic-identification-of-4-methoxyphenylacetone>]

Disclaimer & Data Validity:

The information provided in this document is for Research Use Only (RUO) and is strictly not intended for diagnostic or therapeutic procedures. While BenchChem strives to provide accurate protocols, we make no warranties, express or implied, regarding the fitness of this product for every specific experimental setup.

Technical Support: The protocols provided are for reference purposes. Unsure if this reagent suits your experiment?

Need Industrial/Bulk Grade? [Request Custom Synthesis Quote](#)

BenchChem

Our mission is to be the trusted global source of essential and advanced chemicals, empowering scientists and researchers to drive progress in science and industry.

Contact

Address: 3281 E Guasti Rd
Ontario, CA 91761, United States
Phone: (601) 213-4426
Email: info@benchchem.com

[Contact our Ph.D. Support Team for a compatibility check](#)