

# The Impact of RX-3117 on RNA Synthesis and Integrity: A Technical Guide

**Author:** BenchChem Technical Support Team. **Date:** December 2025

## Compound of Interest

Compound Name: RX-3117

Cat. No.: B1684301

[Get Quote](#)

For Researchers, Scientists, and Drug Development Professionals

## Abstract

**RX-3117**, a novel cytidine analog, has demonstrated significant potential as an anti-cancer agent. Its mechanism of action involves a multi-faceted attack on cellular proliferation, with a pronounced impact on nucleic acid synthesis. This technical guide provides an in-depth analysis of **RX-3117**'s effects on RNA synthesis and integrity, compiling available quantitative data, detailing relevant experimental protocols, and visualizing the key molecular pathways involved. **RX-3117** is selectively activated in tumor cells and subsequently incorporated into both RNA and DNA, leading to the inhibition of their synthesis and downstream cellular processes. While its primary cytotoxic effects are attributed to DNA damage, its influence on RNA metabolism is a critical aspect of its anti-neoplastic activity.

## Introduction

**RX-3117** (fluorocyclopentenyl cytosine) is an orally bioavailable small molecule that belongs to the class of nucleoside analogs.[1] Unlike other cytidine analogs such as gemcitabine, **RX-3117** exhibits a unique pharmacological profile, including resistance to degradation by cytidine deaminase, which contributes to its excellent oral bioavailability.[2][3] The primary mechanism of action of **RX-3117** involves its intracellular activation and subsequent incorporation into nucleic acids, leading to the disruption of DNA and RNA synthesis.[2][4] This guide focuses specifically on the impact of **RX-3117** on RNA synthesis and integrity, providing a comprehensive resource for researchers in oncology and drug development.

## Mechanism of Action: Activation and Incorporation into RNA

The anti-cancer activity of **RX-3117** is contingent upon its intracellular phosphorylation, a process preferentially occurring in tumor cells due to the differential expression of activating enzymes.

### Cellular Uptake and Activation by Uridine-Cytidine Kinase 2 (UCK2)

**RX-3117** enters the cell via the human equilibrative nucleoside transporter 1 (hENT1).[2] Once inside the cell, it is selectively phosphorylated by uridine-cytidine kinase 2 (UCK2) to its monophosphate form, **RX-3117**-monophosphate (**RX-3117**-MP).[5][6] UCK2 is an enzyme that is often overexpressed in tumor cells compared to normal tissues, providing a basis for the tumor-selective activation of **RX-3117**. [2] This initial phosphorylation is the rate-limiting step in the activation cascade. Subsequent phosphorylations by other cellular kinases convert **RX-3117**-MP into its active diphosphate (**RX-3117**-DP) and triphosphate (**RX-3117**-TP) forms.[4]

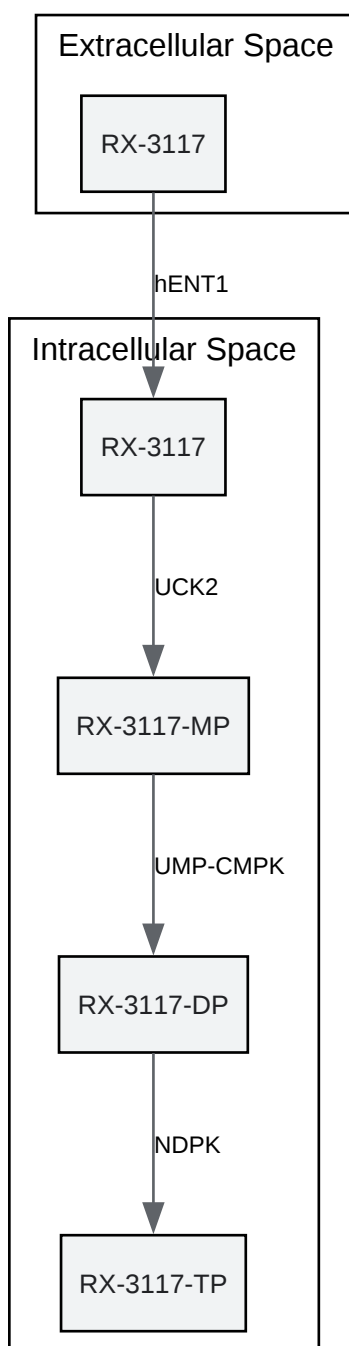

[Click to download full resolution via product page](#)

**Figure 1:** Cellular uptake and activation of **RX-3117**.

## Incorporation into RNA

The active triphosphate metabolite, **RX-3117-TP**, acts as a fraudulent substrate for RNA polymerases and is incorporated into newly synthesized RNA chains.[2][4] This incorporation is

a key mechanism through which **RX-3117** exerts its effects on RNA metabolism. While it is established that **RX-3117** is incorporated into RNA, specific quantitative data on the extent of this incorporation (e.g., the percentage of cytidine residues replaced by **RX-3117**) in various cell lines are not extensively available in the public literature. However, studies have shown that the level of incorporation is higher in cancer cell lines that are more sensitive to the drug. [2]

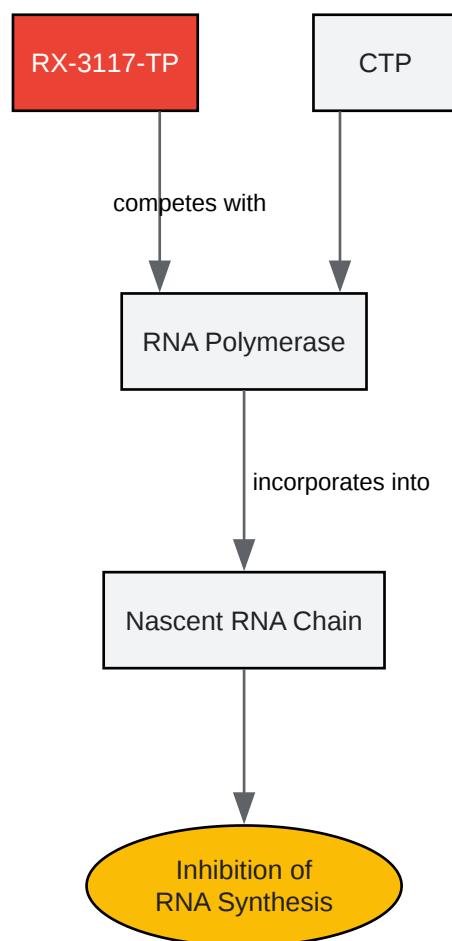

[Click to download full resolution via product page](#)

**Figure 2:** Incorporation of **RX-3117-TP** into RNA.

## Quantitative Impact on RNA Synthesis

The incorporation of **RX-3117-TP** into the growing RNA chain leads to a direct inhibition of RNA synthesis. The degree of inhibition is cell-line dependent and correlates with the intracellular concentration of the active triphosphate metabolite.

Cell Line	Drug Concentration	% Inhibition of RNA Synthesis	Reference
U937 (sensitive)	1 $\mu$ M	90%	[2]
A2780	100 $\mu$ M	90%	[2]
CCRF-CEM	100 $\mu$ M	90%	[2]

Table 1: Inhibition of RNA Synthesis by **RX-3117** in Various Cancer Cell Lines.

## Effect on RNA Integrity

A crucial aspect of any nucleoside analog's mechanism is its potential to compromise the structural integrity of the nucleic acids into which it is incorporated. Based on available data, **RX-3117**, at concentrations equivalent to its IC50 values for cell growth inhibition, does not appear to significantly affect RNA integrity.[2] This suggests that the primary mechanism of its RNA-directed activity is the inhibition of synthesis rather than the induction of widespread RNA degradation.

Cell Line	Treatment Condition	Method of Analysis	Outcome on RNA Integrity	Reference
Various Cancer Cell Lines	IC50 values of RX-3117	Not specified in detail	No significant effect observed	[2]

Table 2: Reported Effects of **RX-3117** on RNA Integrity.

## Downstream Consequences of **RX-3117** Incorporation into RNA

The incorporation of a fraudulent nucleotide into RNA can have several downstream consequences beyond the immediate inhibition of transcription. While specific studies on the downstream effects of **RX-3117** are limited, potential consequences based on the mechanisms of other nucleoside analogs include:

- **Inhibition of RNA Processing:** The presence of an altered nucleotide could interfere with the complex machinery responsible for pre-mRNA splicing and polyadenylation. This could lead to the production of aberrant or non-functional messenger RNAs (mRNAs).
- **Disruption of Ribosome Biogenesis:** The synthesis of ribosomal RNA (rRNA) is a major cellular activity. Inhibition of rRNA synthesis by **RX-3117** would directly impact the production of new ribosomes, which are essential for protein synthesis and cell growth.
- **Altered mRNA Function:** The incorporation of **RX-3117** into mRNA could potentially affect its stability, localization, and translational efficiency.

Further research is required to elucidate the specific downstream effects of **RX-3117** incorporation into different RNA species.

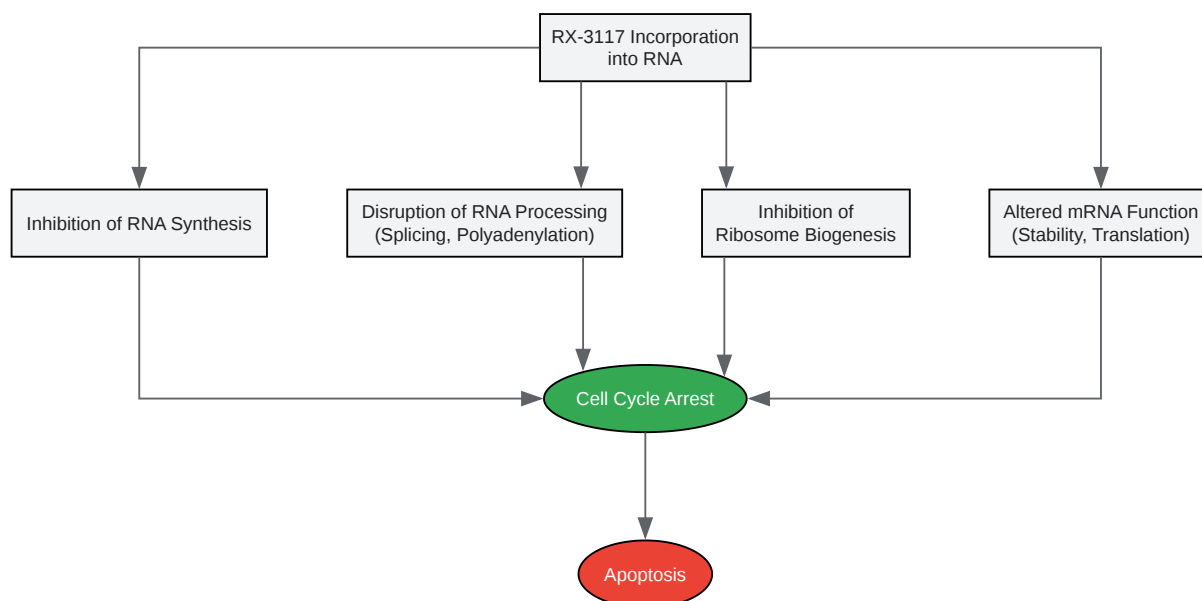

[Click to download full resolution via product page](#)

**Figure 3:** Potential downstream consequences of **RX-3117** incorporation into RNA.

## Experimental Protocols

### UCK2 Enzyme Activity Assay

This assay measures the ability of UCK2 to phosphorylate **RX-3117**.

Materials:

- Purified recombinant UCK2 enzyme
- [<sup>3</sup>H]-**RX-3117**
- Reaction buffer (e.g., 50 mM Tris-HCl pH 7.5, 5 mM MgCl<sub>2</sub>, 2 mM DTT, 10 mM ATP)
- DEAE-cellulose filter paper
- Scintillation cocktail and counter

Procedure:

- Prepare a reaction mixture containing the reaction buffer, purified UCK2 enzyme, and varying concentrations of **RX-3117**.
- Initiate the reaction by adding [<sup>3</sup>H]-**RX-3117**.
- Incubate the reaction at 37°C for a defined period (e.g., 30 minutes).
- Spot an aliquot of the reaction mixture onto DEAE-cellulose filter paper to separate the phosphorylated [<sup>3</sup>H]-**RX-3117** from the unphosphorylated substrate.
- Wash the filter papers extensively to remove unreacted [<sup>3</sup>H]-**RX-3117**.
- Measure the radioactivity retained on the filter paper using a scintillation counter.
- Calculate the enzyme activity based on the amount of phosphorylated product formed over time.

### RNA Synthesis Inhibition Assay

This assay quantifies the effect of **RX-3117** on the rate of RNA synthesis in cultured cells.

#### Materials:

- Cancer cell lines of interest
- Cell culture medium and supplements
- **RX-3117**
- [<sup>3</sup>H]-uridine
- Trichloroacetic acid (TCA)
- Scintillation cocktail and counter

#### Procedure:

- Seed cells in multi-well plates and allow them to adhere overnight.
- Treat the cells with varying concentrations of **RX-3117** for a specified duration.
- Add [<sup>3</sup>H]-uridine to the culture medium and incubate for a short period (e.g., 1-2 hours) to allow for its incorporation into newly synthesized RNA.
- Wash the cells to remove unincorporated [<sup>3</sup>H]-uridine.
- Precipitate the macromolecules, including RNA, by adding cold TCA.
- Wash the precipitate to remove any remaining unincorporated label.
- Lyse the cells and measure the radioactivity of the TCA-precipitable material using a scintillation counter.
- The percentage of RNA synthesis inhibition is calculated by comparing the radioactivity in treated cells to that in untreated control cells.



## RNA Integrity Analysis using Denaturing Agarose Gel Electrophoresis

This method provides a qualitative assessment of RNA integrity.

Materials:

- Total RNA extracted from control and **RX-3117**-treated cells
- Denaturing agarose gel (containing formaldehyde)
- MOPS running buffer
- RNA loading dye (containing formamide and a tracking dye)
- Ethidium bromide or other RNA stain
- UV transilluminator and gel documentation system

Procedure:

- Prepare a denaturing agarose gel containing formaldehyde.
- Denature the RNA samples by heating them in the presence of formamide-containing loading dye.
- Load the denatured RNA samples onto the gel.
- Perform electrophoresis to separate the RNA molecules based on their size.
- Stain the gel with ethidium bromide to visualize the RNA bands.
- Image the gel using a UV transilluminator. Intact total RNA will show two distinct bands corresponding to the 28S and 18S ribosomal RNA (rRNA), with the 28S band being approximately twice as intense as the 18S band. Degraded RNA will appear as a smear.

## RNA Integrity Analysis using Agilent Bioanalyzer

This method provides a quantitative assessment of RNA integrity, yielding an RNA Integrity Number (RIN).

Materials:

- Total RNA extracted from control and **RX-3117**-treated cells
- Agilent RNA 6000 Nano or Pico Kit
- Agilent 2100 Bioanalyzer instrument

Procedure:

- Prepare the gel-dye mix and prime the chip according to the manufacturer's protocol.
- Load the RNA ladder and samples onto the chip.
- Run the chip in the Agilent 2100 Bioanalyzer.
- The software will generate an electropherogram and a gel-like image, and calculate a RIN value for each sample. A RIN value close to 10 indicates high-quality, intact RNA, while lower values indicate degradation.

## Conclusion

**RX-3117**'s impact on RNA synthesis is a significant component of its anti-cancer activity. Its selective activation by UCK2 in tumor cells leads to the production of **RX-3117**-TP, which is subsequently incorporated into nascent RNA chains, resulting in the inhibition of RNA synthesis. While current evidence suggests that **RX-3117** does not compromise RNA integrity at cytotoxic concentrations, its incorporation likely has profound downstream consequences on RNA processing and ribosome biogenesis that warrant further investigation. The experimental protocols detailed in this guide provide a framework for researchers to further explore the intricate molecular mechanisms of **RX-3117** and to evaluate its therapeutic potential in various cancer models. Future studies focusing on the quantitative analysis of **RX-3117** incorporation into different RNA species and the detailed characterization of its impact on RNA-dependent cellular processes will be crucial for a complete understanding of this promising anti-cancer agent.

### Need Custom Synthesis?

BenchChem offers custom synthesis for rare earth carbides and specific isotopic labeling.

Email: [info@benchchem.com](mailto:info@benchchem.com) or [Request Quote Online](#).

## References

- 1. [pdfs.semanticscholar.org](https://pdfs.semanticscholar.org) [[pdfs.semanticscholar.org](https://pdfs.semanticscholar.org)]
- 2. RX-3117 (fluorocyclopentenyl cytosine): a novel specific antimetabolite for selective cancer treatment - PubMed [[pubmed.ncbi.nlm.nih.gov](https://pubmed.ncbi.nlm.nih.gov)]
- 3. [firstwordpharma.com](https://firstwordpharma.com) [[firstwordpharma.com](https://firstwordpharma.com)]
- 4. [researchgate.net](https://researchgate.net) [[researchgate.net](https://researchgate.net)]
- 5. The Cytidine Analog Fluorocyclopentenylcytosine (RX-3117) Is Activated by Uridine-Cytidine Kinase 2 - PMC [[pmc.ncbi.nlm.nih.gov](https://pmc.ncbi.nlm.nih.gov)]
- 6. The Cytidine Analog Fluorocyclopentenylcytosine (RX-3117) Is Activated by Uridine-Cytidine Kinase 2 - PubMed [[pubmed.ncbi.nlm.nih.gov](https://pubmed.ncbi.nlm.nih.gov)]
- To cite this document: BenchChem. [The Impact of RX-3117 on RNA Synthesis and Integrity: A Technical Guide]. BenchChem, [2025]. [Online PDF]. Available at: [<https://www.benchchem.com/product/b1684301#rx-3117-s-impact-on-rna-synthesis-and-integrity>]

---

### Disclaimer & Data Validity:

The information provided in this document is for Research Use Only (RUO) and is strictly not intended for diagnostic or therapeutic procedures. While BenchChem strives to provide accurate protocols, we make no warranties, express or implied, regarding the fitness of this product for every specific experimental setup.

**Technical Support:** The protocols provided are for reference purposes. Unsure if this reagent suits your experiment? [[Contact our Ph.D. Support Team for a compatibility check](#)]

**Need Industrial/Bulk Grade?** [Request Custom Synthesis Quote](#)

# BenchChem

Our mission is to be the trusted global source of essential and advanced chemicals, empowering scientists and researchers to drive progress in science and industry.

## Contact

Address: 3281 E Guasti Rd

Ontario, CA 91761, United States

Phone: (601) 213-4426

Email: [info@benchchem.com](mailto:info@benchchem.com)