

Technical Support Center: AAL993 & Cell Viability Assays

Author: BenchChem Technical Support Team. **Date:** April 2026

Compound of Interest

Compound Name:	AAL993
CAS No.:	269390-77-4
Cat. No.:	B1684630

[Get Quote](#)

This technical support center provides troubleshooting guidance for researchers encountering issues with cell viability assays when using the VEGFR inhibitor, **AAL993**.

Frequently Asked Questions (FAQs)

Q1: My cell viability results with **AAL993** treatment are inconsistent. What could be the cause?

A1: Inconsistent results in tetrazolium-based assays (e.g., MTT, XTT, MTS) can arise from several factors when using **AAL993**. The compound itself may interfere with the reduction of the tetrazolium salt, which is a known issue for some chemical compounds, leading to inaccurate readings. Additionally, it is important to optimize cell density and incubation times for your specific cell line and experimental conditions. Prolonged incubation with certain assay reagents can also be toxic to cells. Finally, ensure that **AAL993** is fully solubilized in the culture medium, as precipitation can lead to variable dosing and results.

Q2: I am observing high background absorbance/fluorescence in my no-cell control wells containing **AAL993**. What should I do?

A2: High background signals can be due to the **AAL993** compound interacting directly with the assay reagent. To confirm this, run a "no-cell" control plate with just the media, **AAL993** at the concentrations used in your experiment, and the assay reagent. If you observe a signal in these wells, it indicates direct interference. Media components, like phenol red, can also contribute to background, so using a phenol red-free medium is recommended if interference is suspected. Improper storage and light exposure can also lead to the degradation of some assay reagents, resulting in a higher background signal.

Q3: My **AAL993**-treated cells show a decrease in viability with an MTT assay, but I'm not sure if it's due to cytotoxicity or reduced proliferation. How can I clarify this?

A3: Tetrazolium-based assays measure metabolic activity, which can reflect a decrease in cell number (cytotoxicity) or a slowing of cell proliferation (cytostatic effect). **AAL993**, as a VEGFR inhibitor, can block signaling pathways crucial for cell proliferation, such as the MAPK/ERK pathway.^{[1][2]} To distinguish between cytotoxicity and cytostatic effects, you can complement your viability assay with a direct measure of cell death, such as a trypan blue exclusion assay, a lactate dehydrogenase (LDH) release assay (for necrosis), or an assay for apoptosis markers like caspase activity.

Q4: Could the solvent used to dissolve **AAL993** be affecting my cell viability assay?

A4: Yes, the solvent (e.g., DMSO) used to dissolve **AAL993** can have its own effects on cell viability, especially at higher concentrations. It is crucial to include a vehicle control in your experiments, which consists of cells treated with the same concentration of the solvent as that used for the highest concentration of **AAL993**. This will help you to distinguish the effect of the compound from the effect of the solvent.

Q5: Are there alternative cell viability assays that are less prone to interference by compounds like **AAL993**?

A5: ATP-based assays, such as the CellTiter-Glo® Luminescent Cell Viability Assay, are often less susceptible to interference from compounds that affect cellular redox processes. These assays measure the level of ATP in viable cells, which is a direct indicator of metabolic activity. Another option is a protease-based viability assay that measures the activity of a live-cell protease. If you suspect interference with your current assay, it is advisable to confirm your results using an orthogonal method that relies on a different biological principle.

Troubleshooting Guide

This guide addresses specific issues that may arise during cell viability assays with **AAL993** treatment.

Issue	Potential Cause	Troubleshooting Steps
<p>Lower than expected IC50 value with MTT/MTS/XTT assays</p>	<p>AAL993 may be directly reducing the tetrazolium salt, leading to a false positive signal for cell viability.</p>	<p>1. No-Cell Control: Run a control plate with media, AAL993 (at various concentrations), and the assay reagent to check for direct chemical reduction. 2. Orthogonal Assay: Confirm results with a non-redox-based assay, such as an ATP-based assay (e.g., CellTiter-Glo®) or a direct cell counting method (e.g., Trypan Blue).</p>
<p>Higher than expected IC50 value with MTT/MTS/XTT assays</p>	<p>AAL993 might be inhibiting cellular reductases without affecting overall cell viability, or the compound could be quenching the colorimetric signal.</p>	<p>1. Visual Inspection: After adding the solubilizing agent (for MTT), visually inspect the wells for complete dissolution of formazan crystals. 2. Spectrophotometer Scan: Perform a full wavelength scan of the wells to check for any shifts in the absorbance peak. 3. Alternative Assay: Use a different viability assay, such as one based on fluorescence or luminescence, to see if the results are consistent.</p>
<p>High variability between replicate wells</p>	<p>Uneven cell plating, incomplete solubilization of AAL993, or edge effects in the microplate.</p>	<p>1. Cell Plating Technique: Ensure a homogenous cell suspension and use proper pipetting techniques to minimize variability in cell seeding. 2. Compound Solubility: Confirm that AAL993 is fully dissolved in your stock solution and diluted</p>

appropriately in the culture medium. 3. Plate Layout: Avoid using the outer wells of the microplate, which are more prone to evaporation and temperature fluctuations. Fill the outer wells with sterile PBS or media.

Decreased viability in vehicle control wells

The concentration of the solvent (e.g., DMSO) is too high and is causing cytotoxicity.

1. Optimize Solvent

Concentration: Determine the maximum concentration of the solvent that does not affect the viability of your cells. Typically, DMSO concentrations should be kept below 0.5%. 2.

Literature Review: Check the literature for the solvent tolerance of your specific cell line.

Experimental Protocols

MTT Cell Viability Assay Protocol

- Cell Plating: Seed cells in a 96-well plate at a predetermined optimal density and allow them to adhere overnight.
- Compound Treatment: Treat cells with various concentrations of **AAL993** (and a vehicle control) and incubate for the desired duration (e.g., 24, 48, or 72 hours).
- MTT Addition: Add 10 μL of 5 mg/mL MTT solution to each well and incubate for 2-4 hours at 37°C.
- Formazan Solubilization: Carefully remove the media and add 100 μL of a solubilization solution (e.g., DMSO or a solution of SDS in HCl) to each well.

- Absorbance Reading: Shake the plate for 15 minutes to ensure complete dissolution of the formazan crystals and measure the absorbance at 570 nm using a microplate reader.

ATP-Based Cell Viability Assay (e.g., CellTiter-Glo®) Protocol

- Cell Plating and Treatment: Follow steps 1 and 2 from the MTT protocol.
- Reagent Preparation: Equilibrate the CellTiter-Glo® reagent to room temperature.
- Cell Lysis: Add a volume of CellTiter-Glo® reagent equal to the volume of cell culture medium in each well.
- Incubation: Mix the contents on an orbital shaker for 2 minutes to induce cell lysis, followed by a 10-minute incubation at room temperature to stabilize the luminescent signal.
- Luminescence Reading: Measure the luminescence using a plate reader.

Visualizations

AAL993 Signaling Pathway Inhibition

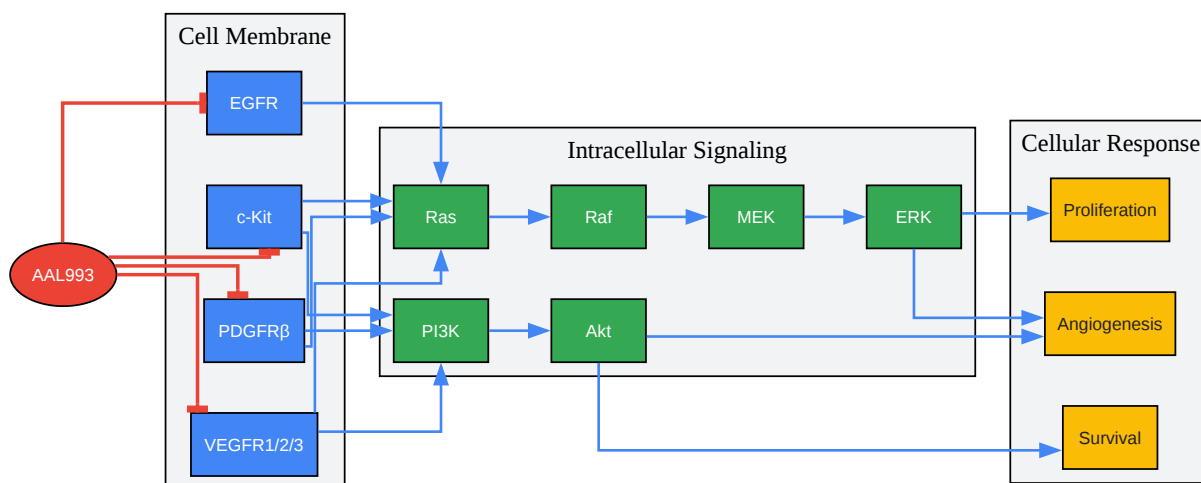

[Click to download full resolution via product page](#)

Caption: **AAL993** inhibits multiple receptor tyrosine kinases, blocking downstream signaling pathways.

Troubleshooting Workflow for Suspected Assay Interference

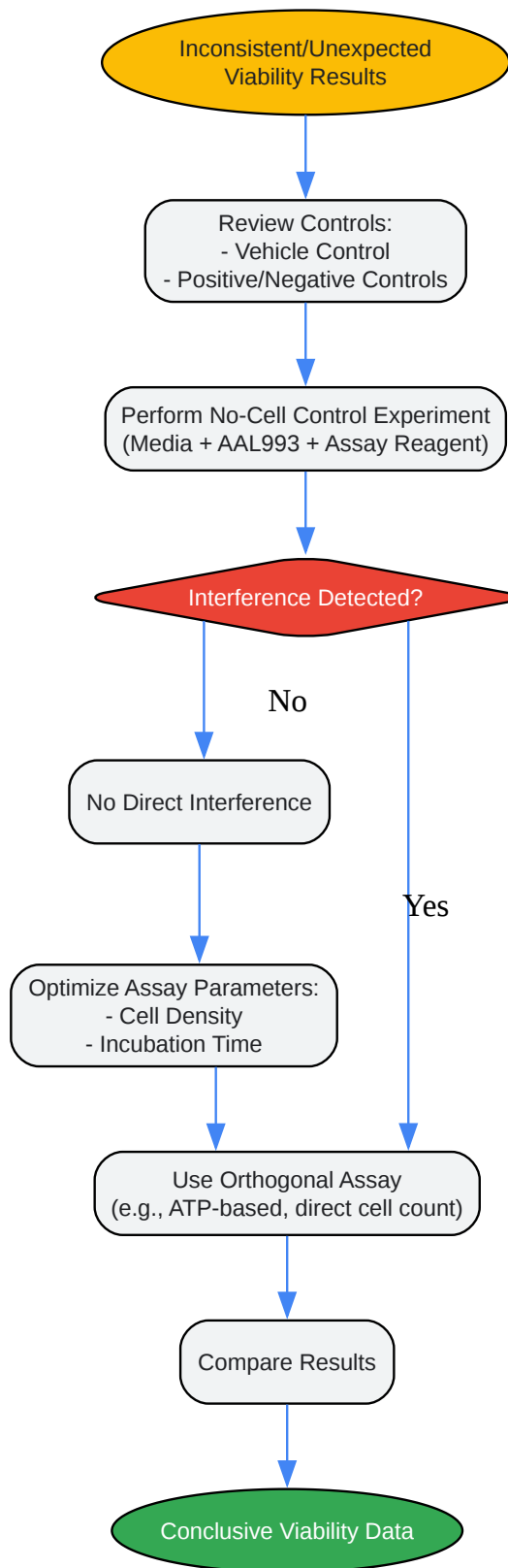

[Click to download full resolution via product page](#)

Caption: A logical workflow to troubleshoot potential **AAL993** interference in cell viability assays.

Need Custom Synthesis?

BenchChem offers custom synthesis for rare earth carbides and specific isotopic labeling.

Email: info@benchchem.com or [Request Quote Online](#).

References

- [1. AAL 993, VEGFR inhibitor \(CAS 340774-69-8\) | Abcam \[abcam.com\]](#)
- [2. medchemexpress.com \[medchemexpress.com\]](#)
- To cite this document: BenchChem. [Technical Support Center: AAL993 & Cell Viability Assays]. BenchChem, [2026]. [Online PDF]. Available at: [\[https://www.benchchem.com/product/b1684630/docs#technical-support-center-aal993-cell-viability-assays\]](https://www.benchchem.com/product/b1684630/docs#technical-support-center-aal993-cell-viability-assays)

Disclaimer & Data Validity:

The information provided in this document is for Research Use Only (RUO) and is strictly not intended for diagnostic or therapeutic procedures. While BenchChem strives to provide accurate protocols, we make no warranties, express or implied, regarding the fitness of this product for every specific experimental setup.

Technical Support: The protocols provided are for reference purposes. Unsure if this reagent suits your experiment?

Need Industrial/Bulk Grade? [Request Custom Synthesis Quote](#)

BenchChem

Our mission is to be the trusted global source of essential and advanced chemicals, empowering scientists and researchers to drive progress in science and industry.

Contact

Address: 3281 E Guasti Rd

Ontario, CA 91761, United States

Phone: (601) 213-4426

Email: info@benchchem.com

[Contact our Ph.D. Support Team for a compatibility check](#)