

# PIK-90 Technical Support Center: Troubleshooting & Quality Control

**Author:** BenchChem Technical Support Team. **Date:** April 2026

## Compound of Interest

Compound Name:	PIK-90
CAS No.:	677338-12-4
Cat. No.:	B1684649

[Get Quote](#)

This technical support center provides researchers, scientists, and drug development professionals with essential guidance on utilizing the PI3K inhibitor, **PIK-90**. The following troubleshooting guides and FAQs address common issues related to lot-to-lot variability and quality control, ensuring the reliability and reproducibility of your experimental results.

## Frequently Asked Questions (FAQs)

**Q1:** We are observing inconsistent results between different batches of **PIK-90**. What could be the cause?

**A1:** Lot-to-lot variability is a known challenge with small molecule inhibitors and can stem from several factors, including differences in purity, the presence of isomers or byproducts from synthesis, and variations in crystalline structure or salt form. Each of these can affect the compound's solubility, stability, and ultimately, its biological activity. Therefore, it is crucial to perform in-house quality control on each new lot.

**Q2:** What are the recommended storage and handling procedures for **PIK-90**?

A2: For long-term stability, **PIK-90** powder should be stored at -20°C. Once dissolved, typically in DMSO to create a stock solution, it is advisable to aliquot the solution into single-use volumes and store them at -20°C or -80°C to minimize freeze-thaw cycles. Before use, allow the aliquot to equilibrate to room temperature and ensure it is fully dissolved.

Q3: My **PIK-90** stock solution appears to have precipitated. Can I still use it?

A3: Precipitation can occur if the storage temperature fluctuates or if the concentration exceeds its solubility limit in the solvent. Gentle warming and vortexing may help to redissolve the compound. However, if precipitation persists, it is recommended to discard the stock solution, as the exact concentration will be unknown, leading to inaccurate experimental results.

Q4: How can I be sure that the **PIK-90** I purchased is active?

A4: The most direct way to confirm the activity of a new lot of **PIK-90** is to perform a functional assay. A common and effective method is to assess its ability to inhibit the PI3K/Akt signaling pathway. This can be achieved by treating a sensitive cell line with the new lot of **PIK-90** and measuring the phosphorylation of Akt (a downstream target of PI3K) via Western blot. A significant reduction in phospho-Akt levels upon treatment would indicate an active compound.

## Troubleshooting Guide

Observed Problem	Potential Cause	Recommended Action
Reduced or no inhibition of Akt phosphorylation in Western blot.	<p>1. Inactive PIK-90 lot: The compound may have degraded or is from a batch with low purity/potency. 2. Incorrect concentration: Errors in calculating dilutions or incomplete dissolution of the compound. 3. Cellular resistance: The cell line used may have developed resistance or has a low dependence on the PI3K pathway.</p>	<p>1. Qualify the new lot: Perform a dose-response experiment to determine the IC50 for Akt phosphorylation inhibition and compare it to previous lots (see QC Experimental Protocols). 2. Verify calculations and solubility: Double-check all dilution calculations. Ensure the compound is fully dissolved in the stock solution before further dilution. 3. Use a sensitive cell line: Confirm that your cell line is responsive to PI3K inhibition.</p>
Inconsistent IC50 values in cell viability assays between experiments.	<p>1. Lot-to-lot variability: Different batches of PIK-90 may have varying potency. 2. Inconsistent experimental conditions: Variations in cell seeding density, incubation time, or reagent concentrations. 3. DMSO concentration: High concentrations of DMSO can be toxic to cells and affect results.</p>	<p>1. Standardize with a reference lot: If possible, maintain a small amount of a "gold standard" lot to include as a control in your assays. 2. Strictly control experimental parameters: Follow a detailed and consistent protocol for all viability assays. 3. Maintain a consistent final DMSO concentration: Ensure the final concentration of DMSO is the same across all wells and is below the toxic threshold for your cell line (typically &lt;0.5%).</p>
Unexpected off-target effects or cellular toxicity.	<p>1. Impurities in the PIK-90 lot: The presence of unknown compounds can lead to unintended biological effects.</p>	<p>1. Consult the Certificate of Analysis: Review the purity data for the specific lot. If not provided, request it from the</p>

2. High inhibitor concentration: Using concentrations significantly above the IC50 can lead to off-target kinase inhibition.

supplier. 2. Perform a dose-response curve: Determine the lowest effective concentration that inhibits the target pathway to minimize off-target effects.

## Quality Control Data Presentation

To ensure consistency across experiments, it is best practice to generate and maintain a record of the quality control data for each new lot of **PIK-90**. Below is a template for how this data can be structured.

Table 1: Hypothetical Quality Control Data for Different Lots of **PIK-90**

Lot Number	Supplier	Purity (from CoA)	In-house IC50 (p-Akt Inhibition)	In-house IC50 (Cell Viability)	Date Tested	Notes
L2024A	Supplier X	>99%	15 nM	1.2 µM	2024-01-15	Reference Lot
L2025B	Supplier X	>99%	18 nM	1.5 µM	2025-03-20	Within acceptable range
L2025C	Supplier Y	>98%	35 nM	2.8 µM	2025-07-10	Higher IC50, adjust concentration

## Mandatory Visualizations

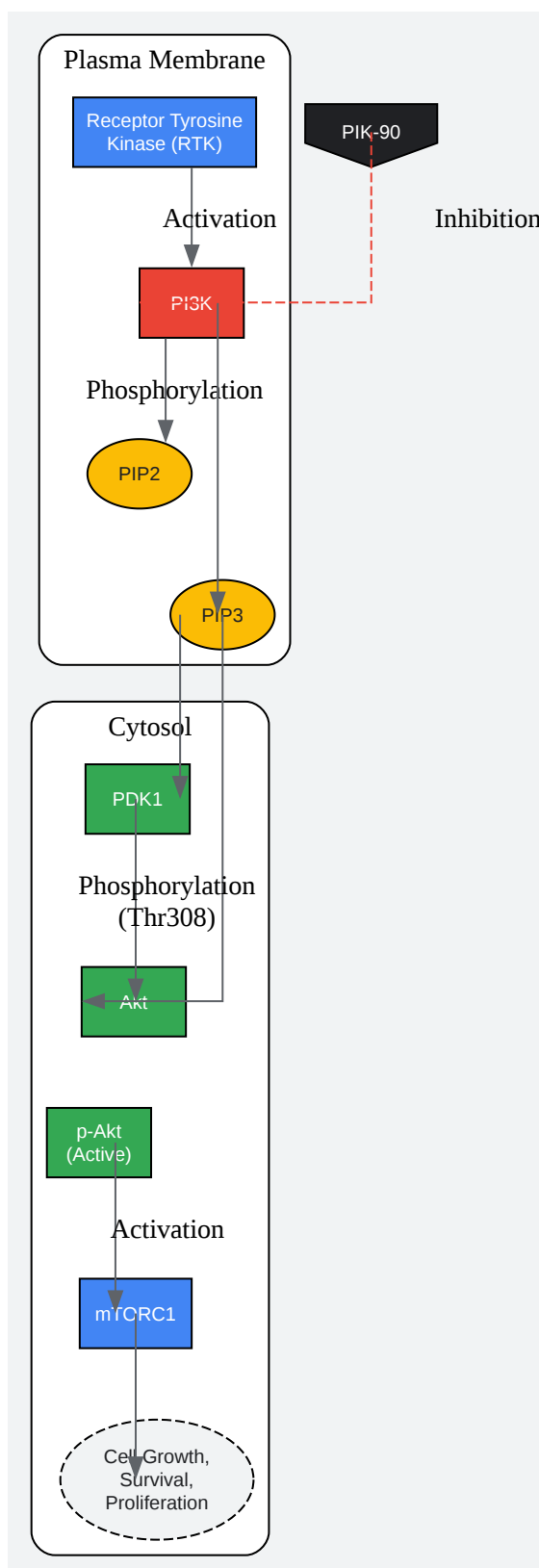

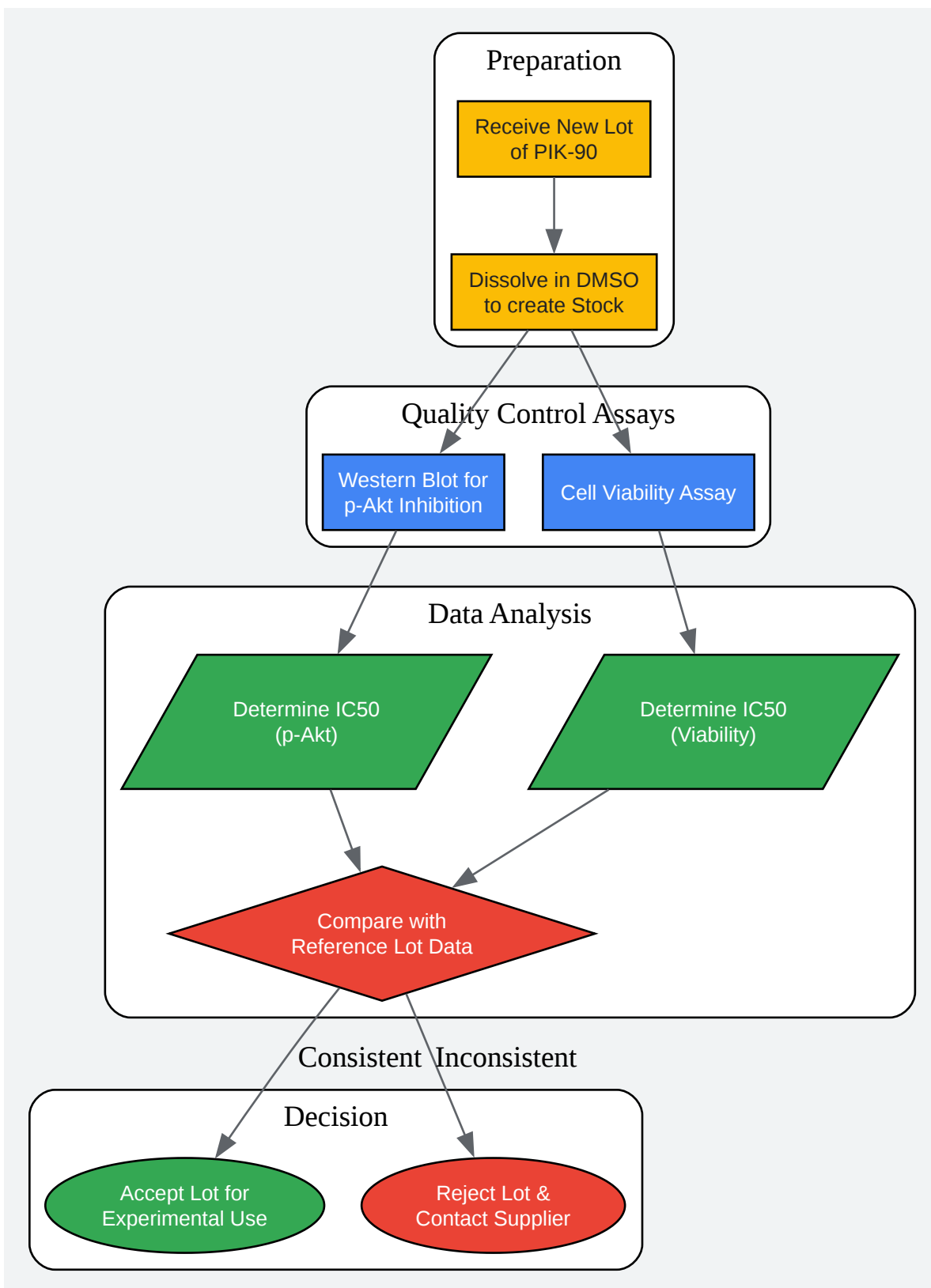

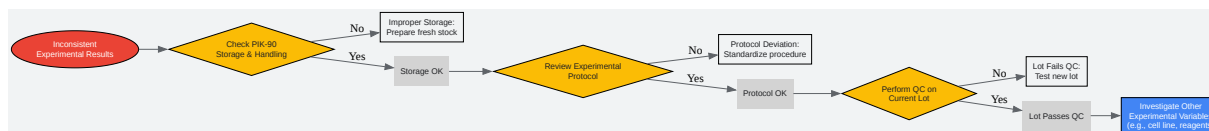

[Click to download full resolution via product page](#)

- To cite this document: BenchChem. [PIK-90 Technical Support Center: Troubleshooting & Quality Control]. BenchChem, [2026]. [Online PDF]. Available at: [\[https://www.benchchem.com/product/b1684649/docs#pik-90-technical-support-center-troubleshooting-quality-control\]](https://www.benchchem.com/product/b1684649/docs#pik-90-technical-support-center-troubleshooting-quality-control)

### Disclaimer & Data Validity:

The information provided in this document is for Research Use Only (RUO) and is strictly not intended for diagnostic or therapeutic procedures. While BenchChem strives to provide accurate protocols, we make no warranties, express or implied, regarding the fitness of this product for every specific experimental setup.

**Technical Support:** The protocols provided are for reference purposes. Unsure if this reagent suits your experiment?

**Need Industrial/Bulk Grade?** [Request Custom Synthesis Quote](#)

## BenchChem

Our mission is to be the trusted global source of essential and advanced chemicals, empowering scientists and researchers to drive progress in science and industry.

### Contact

Address: 3281 E Guasti Rd  
Ontario, CA 91761, United States  
Phone: (601) 213-4426  
Email: [info@benchchem.com](mailto:info@benchchem.com)

Contact our Ph.D. Support Team for a compatibility check