

Control Experiments for HMN-176 Studies: A Comparative Guide

Author: BenchChem Technical Support Team. **Date:** April 2026

Compound of Interest

Compound Name:	HMN-176
CAS No.:	173529-10-7
Cat. No.:	B1684099

[Get Quote](#)

For Researchers, Scientists, and Drug Development Professionals

This guide provides a comparative analysis of **HMN-176**, a potent anti-cancer agent, with alternative compounds. It includes supporting experimental data, detailed protocols for key assays, and visualizations of relevant biological pathways and workflows to assist in the design and interpretation of studies involving this compound.

I. Performance Comparison of HMN-176 and Alternatives

HMN-176 distinguishes itself through a dual mechanism of action: the reversal of multidrug resistance (MDR) and the induction of mitotic arrest. This section compares its efficacy with other compounds that target similar pathways.

A. Cytotoxicity in Cancer Cell Lines

HMN-176 has demonstrated potent cytotoxic effects across a range of cancer cell lines. Its performance is comparable to other Polo-like kinase 1 (PLK1) inhibitors.

Compound	Target(s)	Cell Line	IC50 (nM)	Reference
HMN-176	PLK1 (functional), NF- Y	Mean of various cancer cell lines	112	[1]
HMN-176	PLK1 (functional), NF- Y	P388 (Cisplatin- resistant leukemia)	143	[1]
HMN-176	PLK1 (functional), NF- Y	P388 (Doxorubicin- resistant leukemia)	557	[1]
HMN-176	PLK1 (functional), NF- Y	P388 (Vincristine- resistant leukemia)	265	[1]
Volasertib	PLK1, PLK2, PLK3	Various cancer cell lines	0.87 (for PLK1)	[2]
Onvansertib	PLK1	Group 3 Medulloblastoma cell lines	Low nanomolar range	[3]
Onvansertib	PLK1	Mucinous epithelial ovarian cancer cell lines	Nanomolar range	[1]
Volasertib	PLK1	Glioma stem cells	7.72 nM - 11.4 µM	[4]

B. Reversal of Multidrug Resistance

A key feature of **HMN-176** is its ability to restore chemosensitivity to multidrug-resistant cells by downregulating the MDR1 gene.[5][6] This is achieved by inhibiting the transcription factor NF- κ B from binding to the MDR1 promoter.[5]

Treatment	Cell Line	Effect on Adriamycin GI50	Mechanism	Reference
3 μ M HMN-176	K2/ARS (Adriamycin-resistant ovarian cancer)	~50% decrease	Inhibition of NF-Y binding to MDR1 promoter	[5][6]
Verapamil	Various MDR cell lines	Potentiates cytotoxicity of various chemotherapeutic agents	P-glycoprotein (MDR1 product) inhibitor	[7][8][9][10]

II. Experimental Protocols

Detailed methodologies for key experiments are provided below to facilitate the replication and validation of findings related to **HMN-176**.

A. MDR1 mRNA Expression Analysis by RT-PCR

This protocol quantifies the expression of the MDR1 gene, a key indicator of multidrug resistance.

1. RNA Extraction:

- Isolate total RNA from control and **HMN-176**-treated cells using a suitable kit (e.g., Animal tissue RNA purification kit, Norgen Biotek Corporation) following the manufacturer's instructions.[11]
- Assess RNA quantity and quality using a NanoDrop spectrophotometer.[11]

2. Reverse Transcription (RT):

- Synthesize complementary DNA (cDNA) from 1 μ g of total RNA using a cDNA synthesis kit (e.g., Maxima First Strand cDNA Synthesis Kit for RT-qPCR, Thermo Fisher Scientific).[11]

- Quantify the resulting cDNA using a NanoDrop.[11]

3. Quantitative PCR (qPCR):

- Prepare a reaction mixture containing cDNA, gene-specific primers for MDR1 and a housekeeping gene (e.g., β -actin or GAPDH), and a SYBR Green PCR master mix (e.g., QuantiTect SYBER Green PCR kit, QIAGEN).[11]
- Perform qPCR using a real-time PCR system.
- Analyze the data using the comparative Ct ($\Delta\Delta$ Ct) method to determine the relative expression of MDR1 mRNA.

B. MDR1 Promoter Activity by Luciferase Reporter Assay

This assay measures the transcriptional activity of the MDR1 promoter in response to **HMN-176**.

1. Cell Transfection:

- Co-transfect cells with a firefly luciferase reporter plasmid containing the MDR1 promoter and a Renilla luciferase control plasmid (e.g., pRL-CMV) for normalization of transfection efficiency.[12]

2. Treatment:

- After 24 hours, treat the transfected cells with various concentrations of **HMN-176** or a vehicle control.

3. Cell Lysis:

- After the desired treatment period (e.g., 24-48 hours), wash the cells with PBS and lyse them using a passive lysis buffer.[13][14]

4. Luciferase Activity Measurement:

- Use a dual-luciferase reporter assay system to sequentially measure firefly and Renilla luciferase activity in the cell lysates with a luminometer.[12][15]
- Calculate the relative luciferase activity by normalizing the firefly luciferase signal to the Renilla luciferase signal.

C. NF-Y DNA Binding by Electrophoretic Mobility Shift Assay (EMSA)

EMSA is used to detect the inhibition of NF-Y binding to the Y-box consensus sequence in the MDR1 promoter by **HMN-176**.

1. Probe Preparation:

- Synthesize and anneal complementary oligonucleotides corresponding to the Y-box sequence of the MDR1 promoter.
- Label the double-stranded DNA probe with a radioactive (e.g., ^{32}P) or non-radioactive (e.g., biotin, infrared dye) tag.[16]

2. Binding Reaction:

- Incubate nuclear extracts from control and **HMN-176**-treated cells with the labeled probe in a binding buffer.[17]
- For competition assays, include an excess of unlabeled ("cold") probe.

3. Electrophoresis:

- Resolve the binding reactions on a non-denaturing polyacrylamide gel.[18]

4. Detection:

- Visualize the probe by autoradiography (for radioactive probes) or appropriate imaging systems for non-radioactive probes. A shifted band indicates the protein-DNA complex, and a reduction in this band in **HMN-176**-treated samples indicates inhibition of binding.

D. Cell Cycle Analysis by Flow Cytometry

This protocol assesses the effect of **HMN-176** on cell cycle progression.

1. Cell Preparation and Fixation:

- Harvest control and **HMN-176**-treated cells and wash with cold PBS.
- Fix the cells in cold 70% ethanol while vortexing gently and store at -20°C for at least 2 hours.[19][20]

2. Staining:

- Centrifuge the fixed cells to remove the ethanol and wash with PBS.
- Resuspend the cells in a staining solution containing a fluorescent DNA dye (e.g., Propidium Iodide) and RNase A.[20][21]
- Incubate in the dark at room temperature.

3. Flow Cytometry:

- Analyze the stained cells using a flow cytometer.
- The fluorescence intensity of the DNA dye is proportional to the DNA content, allowing for the quantification of cells in the G0/G1, S, and G2/M phases of the cell cycle.[22]

E. Clonogenic Survival Assay

This assay determines the long-term efficacy of **HMN-176** in inhibiting cancer cell proliferation and survival.

1. Cell Seeding:

- Plate a known number of single cells into 6-well plates or petri dishes. The number of cells seeded will depend on the expected survival rate for each treatment condition.[23]

2. Treatment:

- Treat the cells with various concentrations of **HMN-176** or a vehicle control.

3. Incubation:

- Incubate the plates for 1-3 weeks, depending on the cell line, to allow for colony formation (a colony is typically defined as ≥ 50 cells).[24]

4. Staining and Counting:

- Fix the colonies with a fixative (e.g., 4% paraformaldehyde or 10% formalin) and stain with a solution like 0.5% crystal violet.[23][25]
- Count the number of visible colonies.

5. Analysis:

- Calculate the plating efficiency and the surviving fraction for each treatment condition to assess the effect of **HMN-176** on clonogenic survival.

F. In Vitro Microtubule Nucleation Assay

This assay evaluates the effect of **HMN-176** on the formation of microtubules from centrosomes.

1. Preparation:

- Isolate centrosomes from cultured cells.
- Prepare a reaction mixture containing purified tubulin, GTP, and a fluorescent dye that incorporates into polymerizing microtubules.[26]

2. Nucleation Reaction:

- Incubate the isolated centrosomes with the tubulin mixture in the presence of **HMN-176** or a vehicle control at 37°C to allow for microtubule nucleation and growth.[27]

3. Imaging:

- Fix the reactions and visualize the newly formed microtubule asters using fluorescence microscopy.

4. Quantification:

- Quantify the number and length of microtubules nucleated from the centrosomes to determine the inhibitory effect of **HMN-176**.

III. Visualizing Mechanisms and Workflows

The following diagrams illustrate the signaling pathways affected by **HMN-176** and the general workflows for the described experimental protocols.

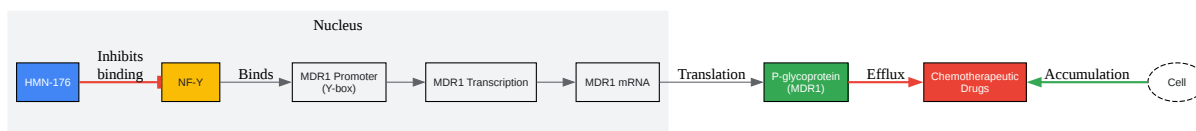

[Click to download full resolution via product page](#)

Caption: **HMN-176** mechanism for overcoming multidrug resistance.

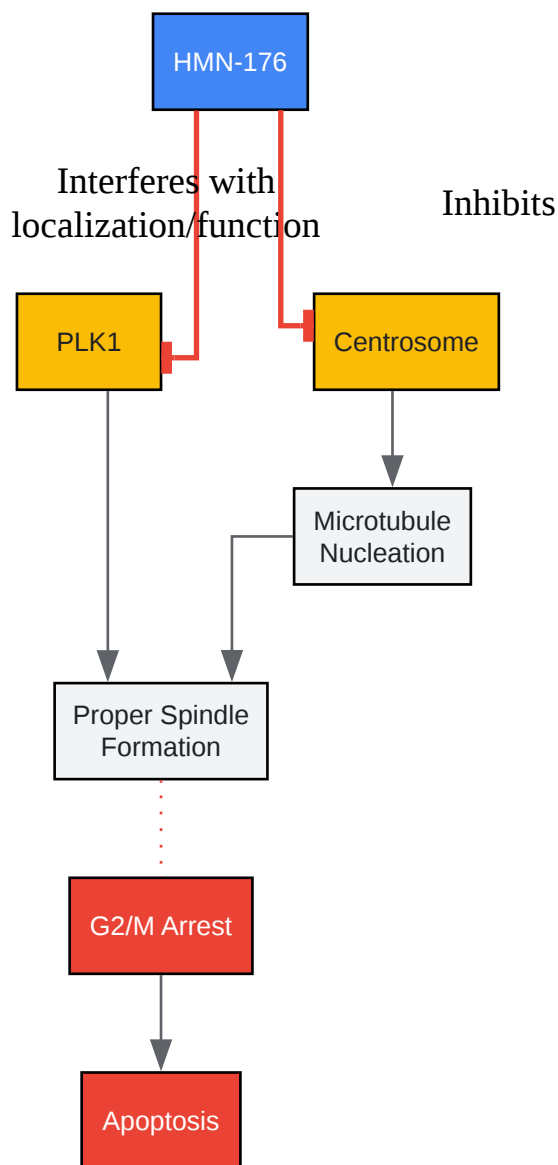

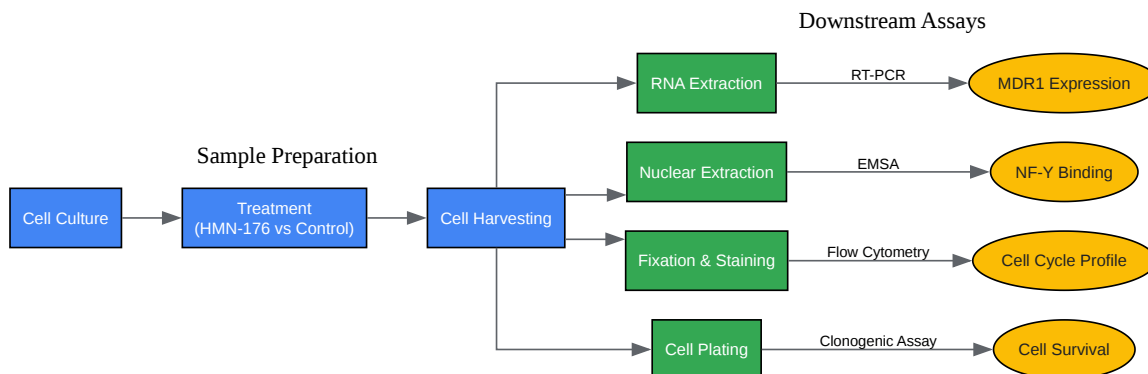

[Click to download full resolution via product page](#)

Need Custom Synthesis?

BenchChem offers custom synthesis for rare earth carbides and specific isotopic labeling.

Email: info@benchchem.com or [Request Quote Online](#).

References

- [1. researchgate.net \[researchgate.net\]](https://www.researchgate.net)
- [2. Discovery and development of the Polo-like kinase inhibitor volasertib in cancer therapy - PMC \[pmc.ncbi.nlm.nih.gov\]](#)
- [3. A novel PLK1 inhibitor onvansertib effectively sensitizes MYC-driven medulloblastoma to radiotherapy - PubMed \[pubmed.ncbi.nlm.nih.gov\]](#)
- [4. The polo-like kinase 1 inhibitor volasertib synergistically increases radiation efficacy in glioma stem cells - PMC \[pmc.ncbi.nlm.nih.gov\]](#)
- [5. HMN-176, an active metabolite of the synthetic antitumor agent HMN-214, restores chemosensitivity to multidrug-resistant cells by targeting the transcription factor NF-Y - PubMed \[pubmed.ncbi.nlm.nih.gov\]](#)

- 6. aacrjournals.org [aacrjournals.org]
- 7. Reversal of multi-drug resistance in human KB cell lines by structural analogs of verapamil - PubMed [pubmed.ncbi.nlm.nih.gov]
- 8. Reversal of multidrug resistance by verapamil analogues - PubMed [pubmed.ncbi.nlm.nih.gov]
- 9. Reversal of multidrug resistance in human colon cancer cells expressing the human MDR1 gene by liposomes in combination with monoclonal antibody or verapamil - PubMed [pubmed.ncbi.nlm.nih.gov]
- 10. By inhibiting Src, verapamil and dasatinib overcome multidrug resistance via increased expression of Bim and decreased expressions of MDR1 and survivin in human multidrug-resistant myeloma cells - PubMed [pubmed.ncbi.nlm.nih.gov]
- 11. Frontiers | MDR1 Gene Polymorphisms and Its Association With Expression as a Clinical Relevance in Terms of Response to Chemotherapy and Prognosis in Ovarian Cancer [frontiersin.org]
- 12. Promoter Deletion Analysis Using a Dual-Luciferase Reporter System | Springer Nature Experiments [experiments.springernature.com]
- 13. Luciferase-based reporter to monitor the transcriptional activity of the SIRT3 promoter - PMC [pmc.ncbi.nlm.nih.gov]
- 14. med.emory.edu [med.emory.edu]
- 15. assaygenie.com [assaygenie.com]
- 16. Transcription Factor mapping and prediction | CMB-UNITO [cmb.i-learn.unito.it]
- 17. researchgate.net [researchgate.net]
- 18. Gel Shift Assays (EMSA) | Thermo Fisher Scientific - US [thermofisher.com]
- 19. Assaying cell cycle status using flow cytometry - PMC [pmc.ncbi.nlm.nih.gov]
- 20. Cell Cycle Analysis by DNA Content - Protocols - Flow Cytometry - UC San Diego Moores Cancer Center [sites.medschool.ucsd.edu]
- 21. Flow cytometry with PI staining | Abcam [abcam.com]
- 22. nanocollect.com [nanocollect.com]
- 23. mcgillradiobiology.ca [mcgillradiobiology.ca]
- 24. Clonogenic Assay: Adherent Cells - PMC [pmc.ncbi.nlm.nih.gov]
- 25. Clonogenic survival assay [bio-protocol.org]
- 26. In vitro reconstitution of branching microtubule nucleation - PMC [pmc.ncbi.nlm.nih.gov]

- [27. In vitro reconstitution assays of microtubule amplification and lattice repair by the microtubule severing enzymes katanin and spastin - PMC \[pmc.ncbi.nlm.nih.gov\]](#)
- To cite this document: BenchChem. [Control Experiments for HMN-176 Studies: A Comparative Guide]. BenchChem, [2026]. [Online PDF]. Available at: [<https://www.benchchem.com/product/b1684099/docs#control-experiments-for-hmn-176-studies-a-comparative-guide>]

Disclaimer & Data Validity:

The information provided in this document is for Research Use Only (RUO) and is strictly not intended for diagnostic or therapeutic procedures. While BenchChem strives to provide accurate protocols, we make no warranties, express or implied, regarding the fitness of this product for every specific experimental setup.

Technical Support: The protocols provided are for reference purposes. Unsure if this reagent suits your experiment?

Need Industrial/Bulk Grade? [Request Custom Synthesis Quote](#)

BenchChem

Our mission is to be the trusted global source of essential and advanced chemicals, empowering scientists and researchers to drive progress in science and industry.

Contact

Address: 3281 E Guasti Rd
Ontario, CA 91761, United States
Phone: (601) 213-4426
Email: info@benchchem.com

[Contact our Ph.D. Support Team for a compatibility check](#)