

UCPH-101 Application Notes for In Vitro Studies

Author: BenchChem Technical Support Team. **Date:** April 2026

Compound of Interest

Compound Name:	Ucph-101
CAS No.:	1118460-77-7
Cat. No.:	B1683363

[Get Quote](#)

For Researchers, Scientists, and Drug Development Professionals

These application notes provide detailed protocols and concentration guidelines for the use of **UCPH-101**, a selective inhibitor of the Excitatory Amino Acid Transporter 1 (EAAT1), in various in vitro experimental settings.

Introduction

UCPH-101 is a potent and selective, non-competitive allosteric inhibitor of the human excitatory amino acid transporter subtype 1 (EAAT1), also known as GLAST.[1][2][3][4] It displays high selectivity for EAAT1 over other EAAT subtypes (EAAT2, EAAT3, EAAT4, and EAAT5).[3][4][5][6] **UCPH-101** has been instrumental in elucidating the physiological roles of EAAT1 and is a valuable tool for studying glutamate homeostasis and excitotoxicity in the central nervous system.[7] This document outlines recommended concentrations, experimental protocols, and key considerations for its use in cell-based assays.

Quantitative Data Summary

The effective concentration of **UCPH-101** can vary depending on the experimental setup, including the cell type, expression level of EAAT1, and the specific assay being performed. The

following table summarizes the key quantitative data from published in vitro studies.

Parameter	Value	Cell Line/System	Assay Type	Reference
IC ₅₀	0.66 μM	HEK-293 cells expressing human EAAT1	[³ H]-D-aspartate uptake	[6][8]
IC ₅₀	0.67 μM	Not specified	Not specified	[7]
IC ₅₀	0.44 μM (12 min incubation)	EAAT1-HEK293 cells	[³ H]-D-Aspartate uptake	[5]
IC ₅₀	1.9 μM (1.5 min incubation)	EAAT1-HEK293 cells	[³ H]-D-Aspartate uptake	[5]
K _i (apparent)	4.3 μM	ASCT2 F136Y/I237M double-mutant transporter	Not specified	[1][2]
K _i (apparent)	77 ± 20 μM	Wild-type ASCT2	Whole-cell current recordings	[1][2]
K _e	0.34 ± 0.03 μM	tsA201 cells expressing human EAAT1	Whole-cell patch-clamp electrophysiology	[5][8]
Effective Concentration	10 μM	tsA201 cells expressing human EAAT1, rat EAAT4, and mouse EAAT5	Whole-cell patch-clamp electrophysiology (to show selectivity)	[3][5][6]
Effective Concentration	100 μM	tsA201 cells expressing EAAT1	Whole-cell patch-clamp electrophysiology (for complete inhibition)	[1]
Effective Concentration	200 μM	HEK293 cells expressing	¹⁴ C serine uptake assay (for	[1][2]

hASCT2

partial inhibition)

Signaling Pathway and Mechanism of Action

UCPH-101 acts as a non-competitive inhibitor of EAAT1.[1][2][4] It binds to an allosteric site on the trimerization domain of the transporter, distinct from the glutamate binding site.[4] This binding induces a long-lasting inactive state of the transporter, thereby blocking the translocation of glutamate across the cell membrane.[1][4]

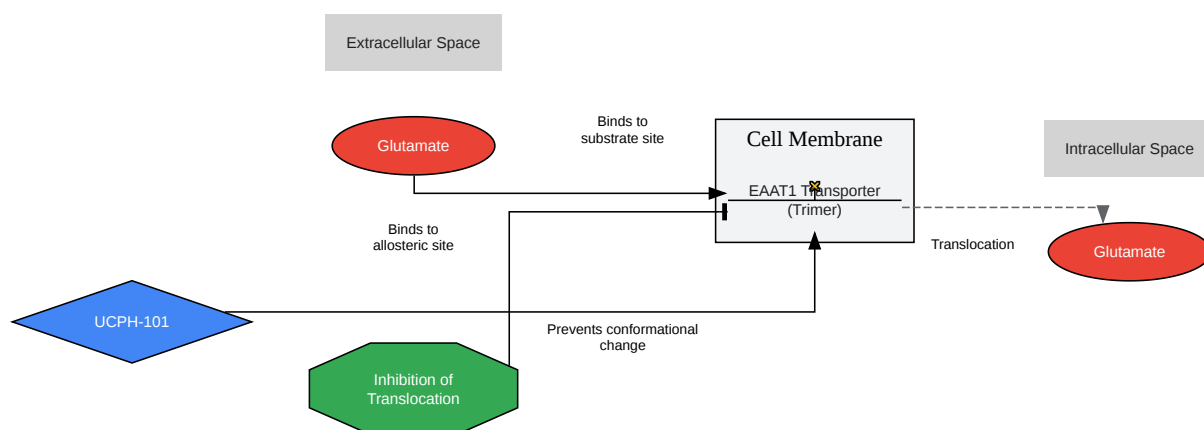

[Click to download full resolution via product page](#)

Caption: Mechanism of **UCPH-101** action on the EAAT1 transporter.

Experimental Protocols

The following are detailed protocols for common in vitro assays using **UCPH-101**.

Cell Culture and Transfection

- Cell Line: Human Embryonic Kidney 293 (HEK293) cells or tsA201 cells are commonly used for their low endogenous EAAT expression and high transfection efficiency.

- Culture Medium: Dulbecco's Modified Eagle's Medium (DMEM) supplemented with 10% Fetal Bovine Serum (FBS), 100 U/mL penicillin, and 100 µg/mL streptomycin.
- Culture Conditions: Maintain cells at 37°C in a humidified atmosphere with 5% CO₂.
- Transfection: For transient expression of EAAT1, transfect cells with a plasmid encoding human EAAT1 using a suitable transfection reagent according to the manufacturer's instructions. Experiments are typically performed 24-48 hours post-transfection.

[³H]-D-Aspartate Uptake Assay

This assay measures the uptake of radiolabeled D-aspartate, a substrate of EAATs, to determine the inhibitory activity of **UCPH-101**.

Materials:

- HEK293 cells expressing EAAT1
- 24-well plates, poly-D-lysine coated
- Krebs-Ringer buffer (120 mM NaCl, 4.7 mM KCl, 2.2 mM CaCl₂, 1.2 mM MgSO₄, 1.2 mM KH₂PO₄, 10 mM HEPES, 10 mM D-glucose, pH 7.4)
- [³H]-D-aspartate
- **UCPH-101** stock solution (in DMSO)
- Scintillation fluid and counter

Protocol:

- Seed EAAT1-expressing HEK293 cells in 24-well plates and grow to confluence.
- Prepare a stock solution of **UCPH-101** in DMSO. Further dilute in Krebs-Ringer buffer to the desired final concentrations. Ensure the final DMSO concentration does not exceed 0.1%.
- Wash the cells twice with warm Krebs-Ringer buffer.

- Pre-incubate the cells with various concentrations of **UCPH-101** in Krebs-Ringer buffer for a specified time (e.g., 1.5 to 12 minutes).[5] Note that the IC₅₀ of **UCPH-101** is dependent on the pre-incubation time due to its slow binding kinetics.[5]
- Initiate the uptake by adding [³H]-D-aspartate to a final concentration of ~100 nM.
- Incubate for 10 minutes at 37°C.
- Terminate the uptake by rapidly aspirating the solution and washing the cells three times with ice-cold Krebs-Ringer buffer.
- Lyse the cells with 0.1 M NaOH.
- Transfer the lysate to scintillation vials, add scintillation fluid, and measure the radioactivity using a scintillation counter.
- Determine non-specific uptake in the presence of a saturating concentration of a non-selective EAAT inhibitor like TBOA (DL-threo-β-benzyloxyaspartate).
- Calculate the specific uptake and determine the IC₅₀ value of **UCPH-101** by fitting the data to a concentration-response curve.

Whole-Cell Patch-Clamp Electrophysiology

This technique directly measures the ion currents associated with EAAT1 activity and its inhibition by **UCPH-101**.

Materials:

- tsA201 cells expressing EAAT1
- Patch-clamp setup (amplifier, micromanipulators, perfusion system)
- Borosilicate glass pipettes
- Extracellular solution (in mM): 140 NaCl, 2.5 KCl, 2 CaCl₂, 2 MgCl₂, 10 HEPES, pH 7.4 with NaOH.

- Intracellular solution (in mM): 130 KSCN, 10 HEPES, 2 MgCl₂, 5 EGTA, pH 7.2 with KOH.
- **UCPH-101** stock solution (in DMSO)
- Glutamate solution

Protocol:

- Plate transfected tsA201 cells on glass coverslips.
- Prepare the extracellular and intracellular solutions. Dilute **UCPH-101** from a DMSO stock into the extracellular solution to the desired final concentration.
- Pull glass pipettes to a resistance of 2-5 MΩ when filled with the intracellular solution.
- Establish a whole-cell recording configuration on an isolated, transfected cell.
- Clamp the cell at a holding potential of -60 mV.
- Apply glutamate (e.g., 1 mM) via the perfusion system to evoke EAAT1-mediated currents.
- After obtaining a stable baseline current, co-apply glutamate with different concentrations of **UCPH-101**. The onset of inhibition by **UCPH-101** is slow, so allow several seconds for the current to reach a steady state.^[1]
- Record the current inhibition at various **UCPH-101** concentrations to determine the K_e value.

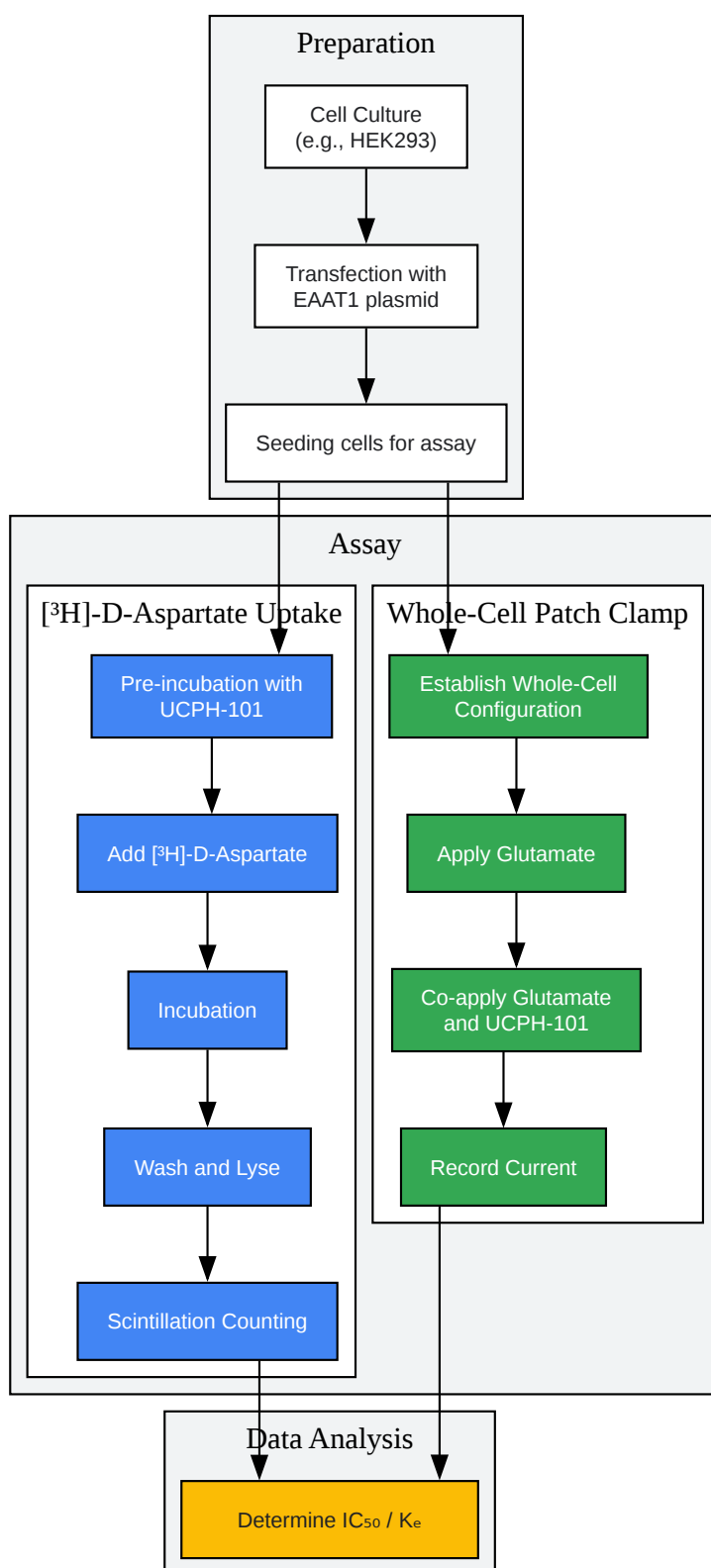

[Click to download full resolution via product page](#)

Caption: General workflow for in vitro assays with **UCPH-101**.

Solubility and Stock Solution Preparation

UCPH-101 is soluble in DMSO up to 25 mM.[3][6][7]

To prepare a 10 mM stock solution in DMSO:

- Weigh out 4.225 mg of **UCPH-101** (MW: 422.48 g/mol).
- Dissolve in 1 mL of high-quality, anhydrous DMSO.
- Vortex briefly to ensure complete dissolution.
- Store the stock solution in aliquots at -20°C.[3] It is recommended to prepare and use solutions on the same day if possible.[3]

Selectivity Considerations

UCPH-101 is highly selective for EAAT1. At concentrations up to 100 μM , it shows negligible inhibitory activity at human EAAT2 and EAAT3.[5] Similarly, it does not significantly inhibit EAAT4 or EAAT5 at concentrations up to 10 μM . [3][5][6] However, it is important to note that **UCPH-101** can partially inhibit the alanine-serine-cysteine transporter 2 (ASCT2) at high concentrations (apparent K_i of $77 \pm 20 \mu\text{M}$). [1][2] This should be taken into consideration when designing experiments and interpreting data, especially if the experimental system expresses high levels of ASCT2.

Conclusion

UCPH-101 is a valuable pharmacological tool for the in vitro study of EAAT1 function. The optimal concentration for use will depend on the specific experimental goals and assay conditions. It is recommended to perform concentration-response curves to determine the most appropriate concentration for your system. The provided protocols offer a starting point for utilizing **UCPH-101** in your research.

Need Custom Synthesis?

BenchChem offers custom synthesis for rare earth carbides and specific isotopic labeling.

Email: info@benchchem.com or [Request Quote Online](#).

References

- [1. Conserved allosteric inhibition mechanism in SLC1 transporters - PMC \[pmc.ncbi.nlm.nih.gov\]](#)
- [2. Conserved allosteric inhibition mechanism in SLC1 transporters | eLife \[elifesciences.org\]](#)
- [3. UCPH 101 | EAAT1 inhibitor | Hello Bio \[hellobio.com\]](#)
- [4. Allosteric modulation of an excitatory amino acid transporter: the subtype-selective inhibitor UCPH-101 exerts sustained inhibition of EAAT1 through an intramonomeric site in the trimerization domain - PubMed \[pubmed.ncbi.nlm.nih.gov\]](#)
- [5. Allosteric Modulation of an Excitatory Amino Acid Transporter: The Subtype-Selective Inhibitor UCPH-101 Exerts Sustained Inhibition of EAAT1 through an Intramonomeric Site in the Trimerization Domain - PMC \[pmc.ncbi.nlm.nih.gov\]](#)
- [6. UCPH 101 | Glutamate \(EAAT\) Transporters | Tocris Bioscience \[tocris.com\]](#)
- [7. UCPH-101, Selective EAAT1 inhibitor \(CAS 1118460-77-7\) | Abcam \[abcam.com\]](#)
- [8. medchemexpress.com \[medchemexpress.com\]](#)
- [To cite this document: BenchChem. \[UCPH-101 Application Notes for In Vitro Studies\]. BenchChem, \[2026\]. \[Online PDF\]. Available at: \[https://www.benchchem.com/product/b1683363/docs#ucph-101-application-notes-for-in-vitro-studies\]](#)

Disclaimer & Data Validity:

The information provided in this document is for Research Use Only (RUO) and is strictly not intended for diagnostic or therapeutic procedures. While BenchChem strives to provide accurate protocols, we make no warranties, express or implied, regarding the fitness of this product for every specific experimental setup.

Technical Support: The protocols provided are for reference purposes. Unsure if this reagent suits your experiment?

Need Industrial/Bulk Grade? [Request Custom Synthesis Quote](#)

BenchChem

Our mission is to be the trusted global source of essential and advanced chemicals, empowering scientists and researchers to drive progress in science and industry.

Contact

Address: 3281 E Guasti Rd
Ontario, CA 91761, United States
Phone: (601) 213-4426
Email: info@benchchem.com

[Contact our Ph.D. Support Team for a compatibility check](#)