

BGP-15: A Modulator of Inflammatory Responses – A Technical Guide

Author: BenchChem Technical Support Team. **Date:** April 2026

Compound of Interest

Compound Name: *Bgp-15*
CAS No.: 66611-37-8
Cat. No.: B1683970

[Get Quote](#)

For Researchers, Scientists, and Drug Development Professionals

This technical guide provides an in-depth analysis of the molecular agent **BGP-15** and its significant role in modulating inflammatory responses. **BGP-15**, chemically known as O-(3-piperidino-2-hydroxy-1-propyl)nicotinic amidoxime, was initially developed as an insulin sensitizer.[1] However, extensive research has unveiled its pleiotropic effects, highlighting its potential as a therapeutic agent for a wide range of inflammatory and oxidative stress-related conditions.[2][3] This document synthesizes key findings on its mechanisms of action, presents quantitative data from pivotal studies, details experimental protocols, and visualizes the complex signaling pathways involved.

Core Mechanisms of Action

BGP-15 exerts its anti-inflammatory effects through a multi-targeted approach, influencing several key cellular signaling pathways. Its primary mechanisms include the inhibition of Poly(ADP-ribose) polymerase 1 (PARP-1), induction of the heat shock response (HSR), modulation of mitogen-activated protein kinase (MAPK) signaling, and the reduction of mitochondrial reactive oxygen species (ROS).[2][4][5]

1.1. PARP-1 Inhibition

Poly(ADP-ribose) polymerase-1 (PARP-1) is a critical enzyme in DNA repair and cell death. However, its overactivation during cellular stress, such as inflammation, can deplete cellular energy stores (NAD⁺ and ATP) and promote cell death.[6] PARP-1 also functions as a nuclear coactivator for pro-inflammatory transcription factors like NF- κ B.[3] **BGP-15** acts as a PARP-1 inhibitor.[2][6] By blocking PARP-1, **BGP-15** prevents the energy depletion associated with its overactivation and curtails the transcription of pro-inflammatory genes, thereby reducing the inflammatory response.[3][6]

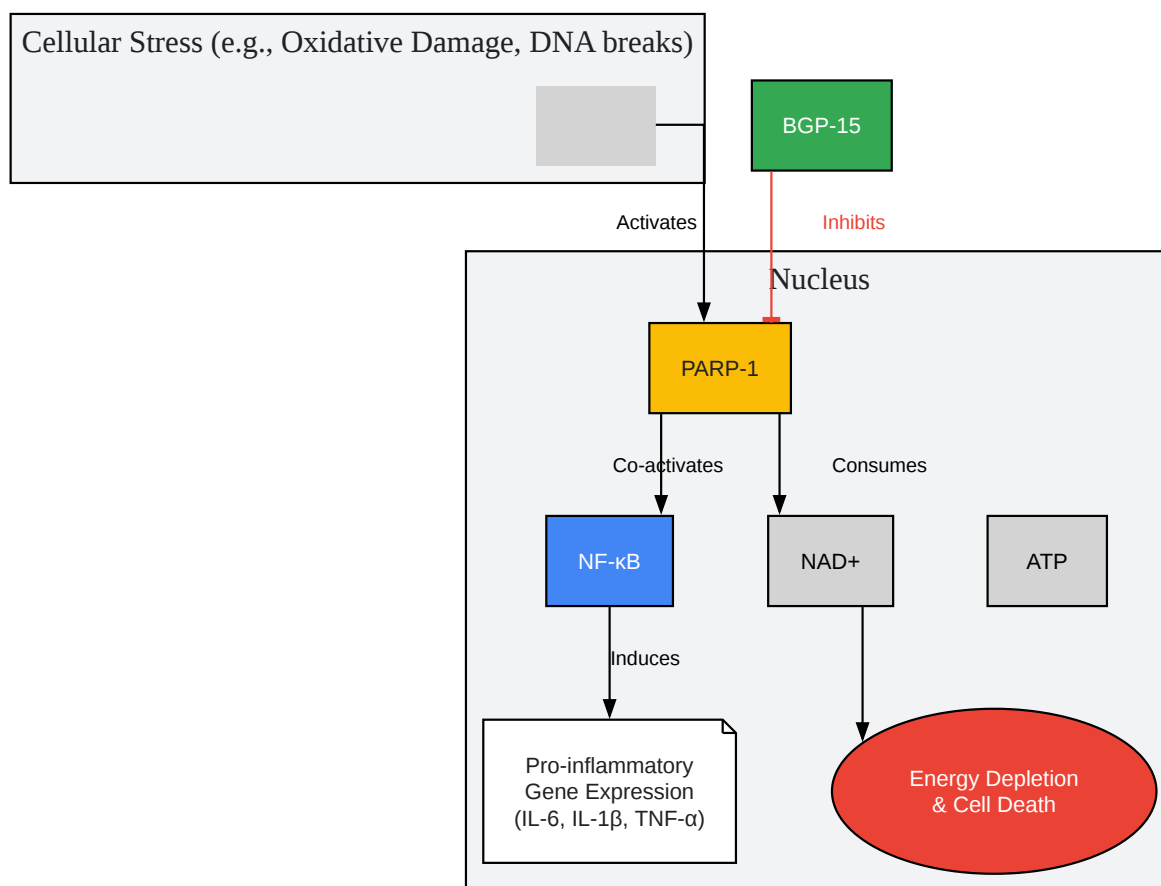

[Click to download full resolution via product page](#)

BGP-15 inhibits PARP-1, reducing inflammation and cell death.

1.2. Heat Shock Response (HSR) Induction

BGP-15 is recognized as a co-inducer of heat shock proteins (HSPs), particularly Hsp72.[2][7] HSPs are molecular chaperones that play a crucial role in maintaining protein homeostasis and protecting cells from stress.[8][9] The heat shock response is a key anti-inflammatory pathway.[10] **BGP-15** enhances the HSR by inhibiting the acetylation of Heat Shock Factor 1 (HSF-1), the master transcriptional regulator of HSPs.[2][7] This prolongs HSF-1's binding to DNA and amplifies the production of HSPs.[7] Induced HSPs, in turn, can inhibit pro-inflammatory signaling kinases like JNK and IKK, the activator of NF- κ B.[11][12]

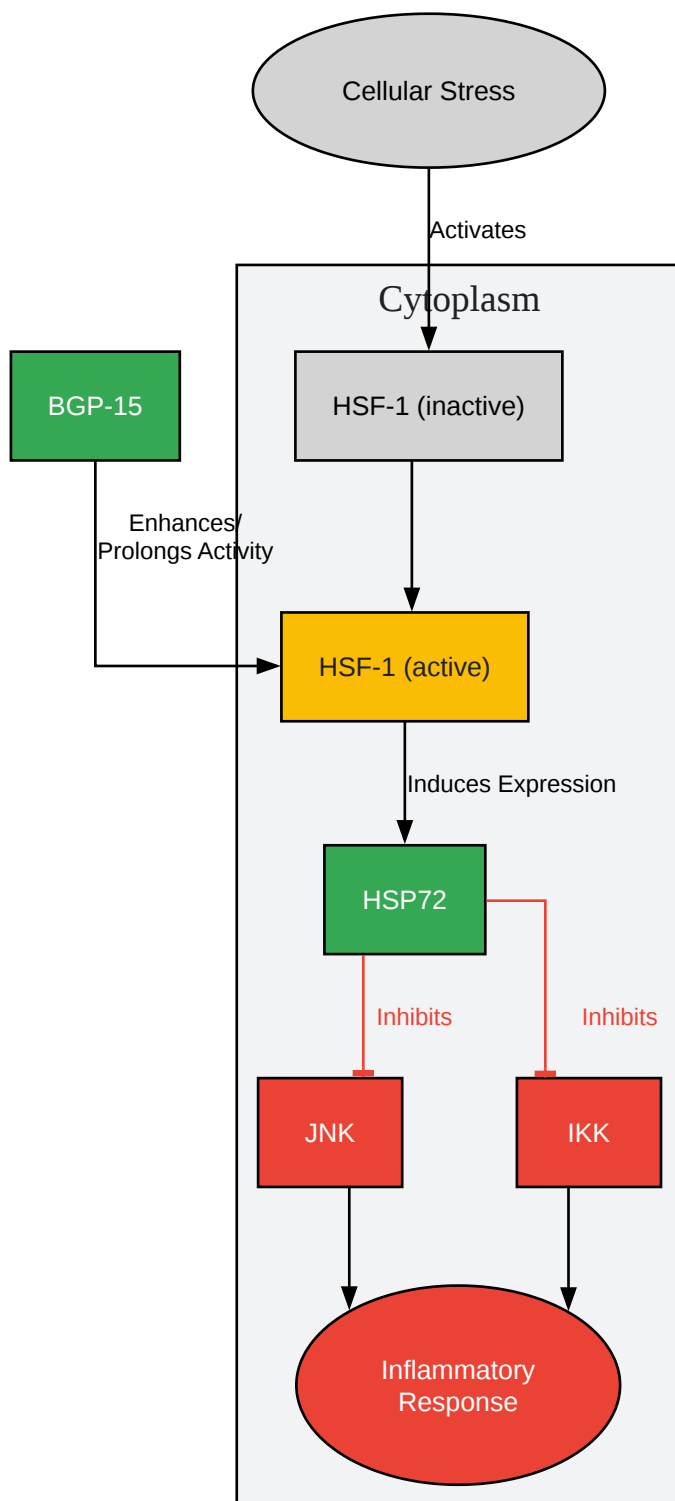

[Click to download full resolution via product page](#)

BGP-15 enhances the Heat Shock Response, suppressing inflammatory kinases.

1.3. Modulation of MAPK and NF-κB Signaling

The Mitogen-Activated Protein Kinase (MAPK) pathways, including p38 and c-Jun N-terminal kinase (JNK), are central to inflammatory signaling.[13] These kinases, when activated by stress stimuli, lead to the activation of transcription factors like AP-1 and contribute to the production of inflammatory cytokines.[5] The NF- κ B pathway is another cornerstone of inflammation, responsible for transcribing numerous pro-inflammatory genes.[14]

BGP-15 has been shown to suppress the activation of JNK and p38 MAPK.[2][5] This effect is partly mediated by the induction of HSPs, which can directly inhibit these kinases.[11] Furthermore, by inhibiting PARP-1, **BGP-15** reduces a key co-activator of NF- κ B, thereby dampening its transcriptional activity.[3] In models of LPS-induced inflammation, **BGP-15** administration effectively nullified the activation of the JNK/p38 pathway and reduced levels of pro-inflammatory factors like TNF- α , IL-1 β , and IL-6.[15]

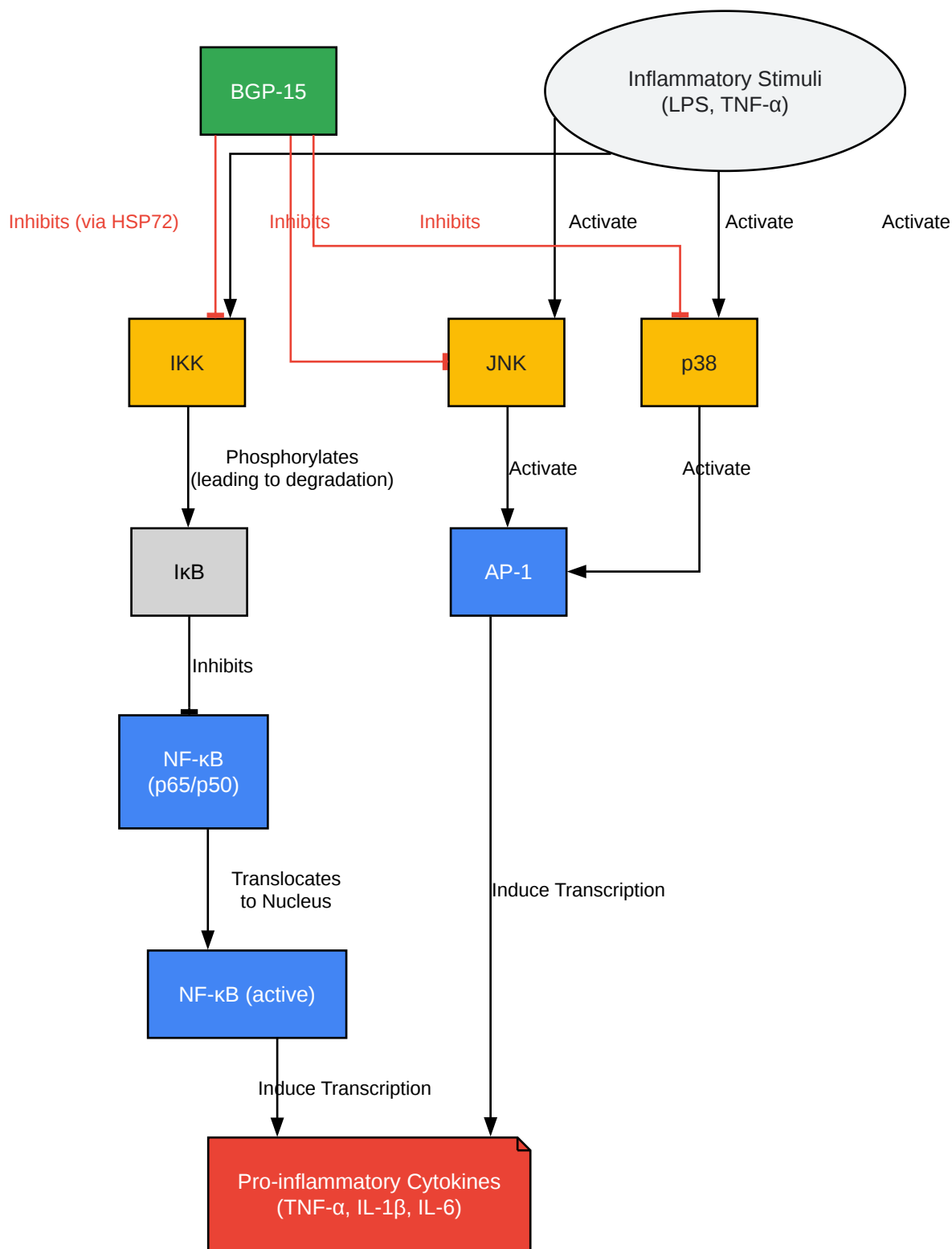

[Click to download full resolution via product page](#)

BGP-15 inhibits key inflammatory signaling pathways, MAPK and NF-κB.

1.4. Mitochondrial Protection and ROS Reduction

Mitochondria are central to cellular metabolism and are also a primary source of reactive oxygen species (ROS). During inflammation, mitochondrial dysfunction can lead to excessive ROS production, which perpetuates cellular damage and amplifies the inflammatory cascade. [16] **BGP-15** has been found to accumulate in mitochondria and protect them from stress.[17] It specifically reduces mitochondrial ROS production at respiratory complexes I and III.[16] By preserving mitochondrial integrity and function, **BGP-15** mitigates oxidative stress, a key driver of inflammation.[16][17] This protective effect has been observed in models using both oxidative stressors like H₂O₂ and inflammatory stimuli like lipopolysaccharide (LPS).[16]

Quantitative Data on Anti-Inflammatory Efficacy

The anti-inflammatory and protective effects of **BGP-15** have been quantified in various preclinical models. The following tables summarize key findings.

Table 1: Effects of **BGP-15** in a Model of Imatinib-Induced Cardiac Inflammation[3]

Parameter Measured	Treatment Group	Result
Pro-inflammatory Cytokines		
IL-6	Imatinib + BGP-15	Significantly reduced compared to Imatinib alone
IL-1 β	Imatinib + BGP-15	Significantly reduced compared to Imatinib alone
IL-18	Imatinib + BGP-15	Significantly reduced compared to Imatinib alone
MCP-1	Imatinib + BGP-15	Significantly reduced compared to Imatinib alone
Inflammatory Markers		
NF- κ B/p65	Imatinib + BGP-15	Significantly reduced compared to Imatinib alone
Myeloperoxidase (MPO) Activity	Imatinib + BGP-15	Significantly reduced compared to Imatinib alone
Antioxidant Markers		
Nrf2	Imatinib + BGP-15	Restored and enhanced compared to Imatinib alone

| HO-1 | Imatinib + **BGP-15** | Restored and enhanced compared to Imatinib alone |

Table 2: Effects of **BGP-15** in a Model of Collagen-Induced Arthritis (CIA) in Mice[18]

Parameter Measured	Treatment Type	Result
Incidence of Arthritis	Prophylactic	Reduced by 28%
Paw Swelling	Prophylactic & Therapeutic	Significantly reduced ($p \leq 0.01$)
Grip Strength	Prophylactic & Therapeutic	Significantly improved ($p \leq 0.05$)
Area of Inflammation (Histology)	Therapeutic	Significantly reduced ($p \leq 0.05$)
Area of Erosion (Histology)	Therapeutic	Significantly reduced ($p \leq 0.01$)

| Number of Osteoclasts (Histology) | Therapeutic | Significantly reduced ($p \leq 0.05$) |

Table 3: Effects of **BGP-15** on LPS-Induced Mitochondrial Dysfunction in U-251 MG Cells[16]

Parameter Measured	Treatment Group	Result
Mitochondrial Depolarization	LPS + BGP-15 (50 μM)	Significantly attenuated compared to LPS alone

| ROS Production | LPS + **BGP-15** (50 μ M) | Significantly reduced ($p < 0.001$) compared to LPS alone |

Experimental Protocols and Methodologies

The following sections detail the methodologies used in key studies to evaluate the anti-inflammatory effects of **BGP-15**.

3.1. In Vivo Model: Imatinib-Induced Cardiac Inflammation

- Animal Model: Male Wistar rats.[3]
- Induction of Inflammation: Animals were treated with imatinib (Imtb) at a dose of 60 mg/kg/day for 14 days.[3]

- **BGP-15** Administration: A treatment group received Imtb co-administered with **BGP-15** at a dose of 10 mg/kg/day.[3]
- Endpoint Analysis: At the end of the 14-day period, hearts were harvested. Protein levels and activity of inflammatory markers (NF- κ B/p65, MPO, HMGB1), cytokines (IL-6, IL-1 β , IL-18, MCP-1), and antioxidant proteins (Nrf2, HO-1) were measured using Western blot and Legendplex assays. Cardiac tissue was also analyzed via immunohistochemistry.[3]

3.2. In Vivo Model: Collagen-Induced Arthritis (CIA)

- Animal Model: Male DBA/1 mice.[18]
- Induction of Arthritis: Arthritis was induced by an intradermal injection of bovine type II collagen (bCII) emulsified with Freund's adjuvant.[18]
- **BGP-15** Administration:
 - Prophylactic: **BGP-15** was administered in drinking water one week prior to the first immunization.[18]
 - Therapeutic: **BGP-15** was administered in drinking water upon the first appearance of arthritic symptoms.[18]
- Endpoint Analysis: Arthritis incidence and severity (paw swelling, grip strength) were monitored for 28 days. At the end of the study, hind paws were collected for histological evaluation of inflammation, bone erosion, and osteoclast numbers. Draining lymph nodes were analyzed by flow cytometry.[18]

3.3. In Vitro Model: LPS-Induced Inflammation in Glioblastoma Cells

- Cell Line: U-251 MG human malignant glioblastoma cells (sensitive to LPS).[16]
- Induction of Inflammation: Cells were exposed to 1 μ g/mL of lipopolysaccharide (LPS) for one hour.[16]
- **BGP-15** Treatment: **BGP-15** was added at a concentration of 50 μ M concurrently with LPS. [16]

- Endpoint Analysis:
 - Mitochondrial Membrane Potential: Assessed using the fluorescent dye JC-1. A shift from red to green fluorescence indicates depolarization.[16]
 - Mitochondrial ROS Production: Measured using MitoSOX, a fluorescent probe specific for mitochondrial superoxide.[16]

Visualized Experimental Workflow

The diagram below illustrates a generalized workflow for assessing the anti-inflammatory properties of a compound like **BGP-15**.

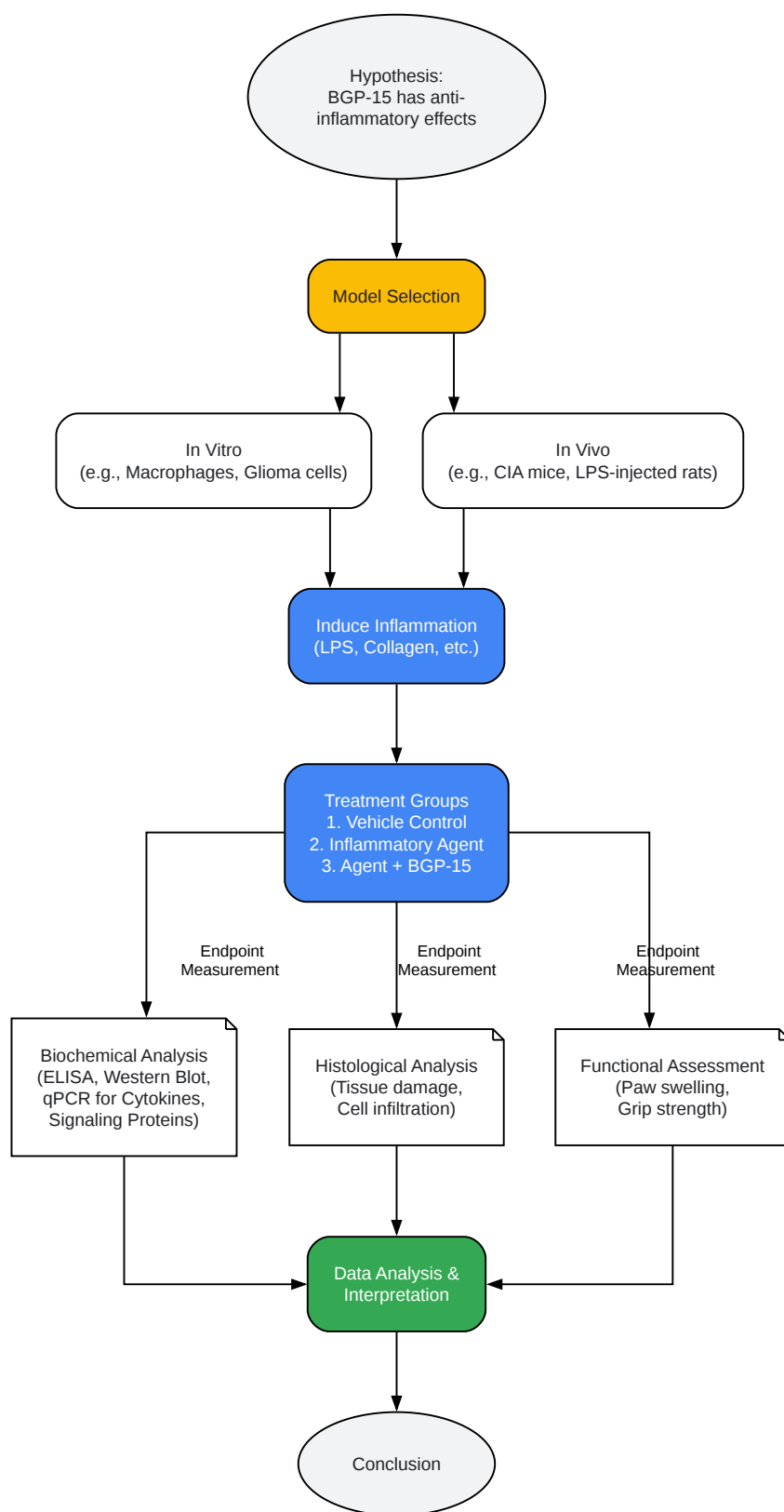

[Click to download full resolution via product page](#)

Generalized workflow for evaluating **BGP-15**'s anti-inflammatory effects.

Conclusion

BGP-15 is a multi-faceted compound that modulates inflammatory responses through several interconnected mechanisms. Its ability to inhibit PARP-1, enhance the cytoprotective heat shock response, suppress key inflammatory kinases like JNK and p38, and protect mitochondria from oxidative stress positions it as a promising therapeutic candidate. The preclinical data robustly demonstrates its efficacy in reducing inflammatory markers, mitigating tissue damage, and improving functional outcomes in various models of inflammation. For drug development professionals, **BGP-15** represents a compelling lead compound whose pleiotropic effects could be advantageous in treating complex diseases where inflammation and cellular stress are intertwined pathological drivers. Further clinical investigation is warranted to translate these significant preclinical findings into effective treatments for human inflammatory diseases.

Need Custom Synthesis?

BenchChem offers custom synthesis for rare earth carbides and specific isotopic labeling.

Email: info@benchchem.com or [Request Quote Online](#).

References

- [1. Pharmacological Overview of the BGP-15 Chemical Agent as a New Drug Candidate for the Treatment of Symptoms of Metabolic Syndrome - PubMed \[pubmed.ncbi.nlm.nih.gov\]](#)
- [2. Pharmacological Overview of the BGP-15 Chemical Agent as a New Drug Candidate for the Treatment of Symptoms of Metabolic Syndrome - PMC \[pmc.ncbi.nlm.nih.gov\]](#)
- [3. Biochemical Insights into the Effects of a Small Molecule Drug Candidate on Imatinib-Induced Cardiac Inflammation - PMC \[pmc.ncbi.nlm.nih.gov\]](#)
- [4. researchgate.net \[researchgate.net\]](#)
- [5. BGP-15, a PARP-inhibitor, prevents imatinib-induced cardiotoxicity by activating Akt and suppressing JNK and p38 MAP kinases - PubMed \[pubmed.ncbi.nlm.nih.gov\]](#)
- [6. BGP-15 - a novel poly\(ADP-ribose\) polymerase inhibitor - protects against nephrotoxicity of cisplatin without compromising its antitumor activity - PubMed \[pubmed.ncbi.nlm.nih.gov\]](#)
- [7. The HSP co-inducer BGP-15 can prevent the metabolic side effects of the atypical antipsychotics - PMC \[pmc.ncbi.nlm.nih.gov\]](#)

- 8. Resolution of inflammation in chronic disease via restoration of the heat shock response (HSR) - PMC [[pmc.ncbi.nlm.nih.gov](https://pubmed.ncbi.nlm.nih.gov)]
- 9. Chaperone co-inducer BGP-15 inhibits histone deacetylases and enhances the heat shock response through increased chromatin accessibility - PubMed [pubmed.ncbi.nlm.nih.gov]
- 10. researchgate.net [researchgate.net]
- 11. researchgate.net [researchgate.net]
- 12. Heat-shock proteins induce T-cell regulation of chronic inflammation - PubMed [pubmed.ncbi.nlm.nih.gov]
- 13. researchgate.net [researchgate.net]
- 14. NF- κ B Signaling | Cell Signaling Technology [cellsignal.com]
- 15. BGP-15 alleviates LPS-induced depression-like behavior by promoting mitophagy - PubMed [pubmed.ncbi.nlm.nih.gov]
- 16. BGP-15 Protects against Oxidative Stress- or Lipopolysaccharide-Induced Mitochondrial Destabilization and Reduces Mitochondrial Production of Reactive Oxygen Species - PMC [[pmc.ncbi.nlm.nih.gov](https://pubmed.ncbi.nlm.nih.gov)]
- 17. BGP-15 Protects against Oxidative Stress- or Lipopolysaccharide-Induced Mitochondrial Destabilization and Reduces Mitochondrial Production of Reactive Oxygen Species - PubMed [pubmed.ncbi.nlm.nih.gov]
- 18. A9.9 Treatment with BGP-15, a Novel Insulin Sensitiser Attenuates Collagen-Induced Arthritis in DBA/1 Mice | Annals of the Rheumatic Diseases [ard.bmj.com]
- To cite this document: BenchChem. [BGP-15: A Modulator of Inflammatory Responses – A Technical Guide]. BenchChem, [2026]. [Online PDF]. Available at: [<https://www.benchchem.com/product/b1683970/docs#bgp-15-a-modulator-of-inflammatory-responses-a-technical-guide>]

Disclaimer & Data Validity:

The information provided in this document is for Research Use Only (RUO) and is strictly not intended for diagnostic or therapeutic procedures. While BenchChem strives to provide accurate protocols, we make no warranties, express or implied, regarding the fitness of this product for every specific experimental setup.

Technical Support: The protocols provided are for reference purposes. Unsure if this reagent suits your experiment?

Need Industrial/Bulk Grade? [Request Custom Synthesis Quote](#)

BenchChem

Our mission is to be the trusted global source of essential and advanced chemicals, empowering scientists and researchers to drive progress in science and industry.

Contact

Address: 3281 E Guasti Rd

Ontario, CA 91761, United States

Phone: (601) 213-4426

Email: info@benchchem.com

[Contact our Ph.D. Support Team for a compatibility check](#)