

Technical Support Center: TG 100572 In Vitro Applications

Author: BenchChem Technical Support Team. **Date:** April 2026

Compound of Interest

Compound Name: TG 100801
CAS No.: 867331-82-6
Cat. No.: B1682778

[Get Quote](#)

This technical support center provides researchers, scientists, and drug development professionals with essential information, troubleshooting guides, and frequently asked questions (FAQs) regarding the in vitro use of TG 100572, a multi-targeted kinase inhibitor.

Frequently Asked Questions (FAQs)

Q1: What is TG 100572 and what are its primary targets?

A1: TG 100572 is a potent, small molecule, multi-targeted kinase inhibitor. Its primary targets include receptor tyrosine kinases (RTKs) involved in angiogenesis and Src family kinases. Specifically, it shows sub-nanomolar to low nanomolar inhibitory activity against Vascular Endothelial Growth Factor Receptors (VEGFR1, VEGFR2), Fibroblast Growth Factor Receptors (FGFR1, FGFR2), Platelet-Derived Growth Factor Receptor β (PDGFR β), and the Src family kinases (Src, Fgr, Fyn, Hck, Lck, Lyn, Yes).[1][2]

Q2: What are the known IC50 values for TG 100572 against its primary targets?

A2: The in vitro half-maximal inhibitory concentrations (IC50) for TG 100572 against its key kinase targets are summarized in the table below.

Q3: Has TG 100572 been profiled against a broad panel of kinases to identify off-target effects?

A3: While the selectivity of TG 100572 has been characterized against a specific panel of RTKs and Src family kinases, comprehensive screening data against a broad, unbiased kinome panel is not publicly available. Therefore, a complete off-target profile is not fully defined in the public domain. Researchers should exercise caution and consider performing broader kinase profiling to identify potential off-target interactions relevant to their specific experimental context.

Q4: What are the potential off-target liabilities for a multi-targeted inhibitor of Src and VEGFR?

A4: Inhibitors targeting the conserved ATP-binding site of kinases, like TG 100572, can potentially interact with other kinases. Given its activity against Src and VEGFR families, potential off-target effects could include inhibition of other kinases involved in cell signaling, proliferation, and survival.[3][4] Off-target effects of VEGF inhibitors have been associated with cardiovascular toxicities in clinical settings.[3]

Q5: What is the recommended solvent and storage condition for TG 100572?

A5: TG 100572 is typically dissolved in dimethyl sulfoxide (DMSO) to create a stock solution. For long-term storage, it is advisable to store the DMSO stock solution at -20°C or -80°C. Aliquoting the stock solution is recommended to avoid repeated freeze-thaw cycles.

Data Presentation

Table 1: In Vitro Kinase Inhibition Profile of TG 100572

Target Family	Kinase Target	IC50 (nM)
Receptor Tyrosine Kinases	VEGFR1	2
	VEGFR2	7
	FGFR1	2
	FGFR2	16
	PDGFR β	13
Src Family Kinases	Src	1
	Fgr	5
	Fyn	0.5
	Hck	6
	Lck	0.1
	Lyn	0.4
	Yes	0.2

Data compiled from multiple sources.^{[1][2]}

Experimental Protocols

Protocol 1: In Vitro Kinase Inhibition Assay (Representative TR-FRET Protocol)

This protocol is a representative example of a Time-Resolved Fluorescence Resonance Energy Transfer (TR-FRET) assay, a common method for determining kinase inhibitor potency. Specific conditions should be optimized for each kinase-substrate pair.

Materials:

- Purified recombinant kinases (e.g., VEGFR2, Src)
- Fluorescein-labeled substrate peptide

- TG 100572
- ATP
- Kinase reaction buffer (e.g., 50 mM HEPES pH 7.5, 10 mM MgCl₂, 1 mM EGTA, 0.01% Brij-35)
- TR-FRET detection buffer
- Europium- or Terbium-labeled anti-phospho-substrate antibody
- Low-volume 384-well assay plates (black or white)
- TR-FRET compatible plate reader

Procedure:

- **Compound Preparation:** Prepare a serial dilution of TG 100572 in 100% DMSO. Further dilute these solutions in kinase reaction buffer to achieve the desired final concentrations. The final DMSO concentration in the assay should be kept constant and low (e.g., <1%).
- **Kinase Reaction:**
 - Add 2.5 μL of the diluted TG 100572 or vehicle (DMSO) to the wells of the 384-well plate.
 - Add 2.5 μL of a 2X solution of the kinase in kinase reaction buffer.
 - Incubate for 15-30 minutes at room temperature to allow for inhibitor binding.
 - Initiate the kinase reaction by adding 5 μL of a 2X solution of ATP and fluorescein-labeled substrate in kinase reaction buffer.
 - Incubate for 60-120 minutes at room temperature. The optimal incubation time should be determined empirically.
- **Detection:**

- Stop the kinase reaction by adding 10 μ L of TR-FRET detection buffer containing EDTA and the Europium/Terbium-labeled antibody.
- Incubate for at least 60 minutes at room temperature to allow for antibody binding.
- Read the plate on a TR-FRET plate reader, measuring the emission at both the donor (e.g., 620 nm for Europium) and acceptor (e.g., 665 nm for fluorescein) wavelengths after a time delay.
- Data Analysis:
 - Calculate the TR-FRET ratio (Acceptor Emission / Donor Emission).
 - Plot the TR-FRET ratio against the logarithm of the TG 100572 concentration.
 - Fit the data using a four-parameter logistic equation to determine the IC50 value.

Protocol 2: Cell Proliferation Assay

This protocol is based on the methodology used to assess the effect of TG 100572 on the proliferation of human retinal microvascular endothelial cells (hRMVEC).[1]

Materials:

- Human retinal microvascular endothelial cells (hRMVEC)
- Cell culture medium (e.g., EGM-2)
- Fetal Bovine Serum (FBS)
- Heparin
- Recombinant human VEGF (rhVEGF)
- TG 100572
- DMSO
- 96-well cell culture plates

- XTT cell proliferation assay kit

Procedure:

- Cell Seeding: Seed hRMVEC in 96-well plates at an appropriate density and allow them to adhere overnight.
- Compound Treatment:
 - Prepare serial dilutions of TG 100572 in cell culture medium containing 10% FBS, 50 µg/mL heparin, and 50 ng/mL rhVEGF.[1]
 - Remove the overnight culture medium from the cells and replace it with the medium containing the different concentrations of TG 100572 (ranging from 2 nM to 5 µM) or DMSO as a vehicle control.[1]
- Incubation: Incubate the cells for 48 hours at 37°C in a humidified incubator with 5% CO₂. [1]
- Cell Viability Measurement:
 - After the incubation period, assess cell proliferation using an XTT-based assay according to the manufacturer's instructions.[1]
 - Measure the absorbance on a microplate reader.
- Data Analysis:
 - Normalize the absorbance values to the vehicle-treated control wells.
 - Plot the percentage of cell proliferation against the logarithm of the TG 100572 concentration.
 - Determine the ED50 (effective dose for 50% inhibition of proliferation) from the resulting dose-response curve.

Visualizations

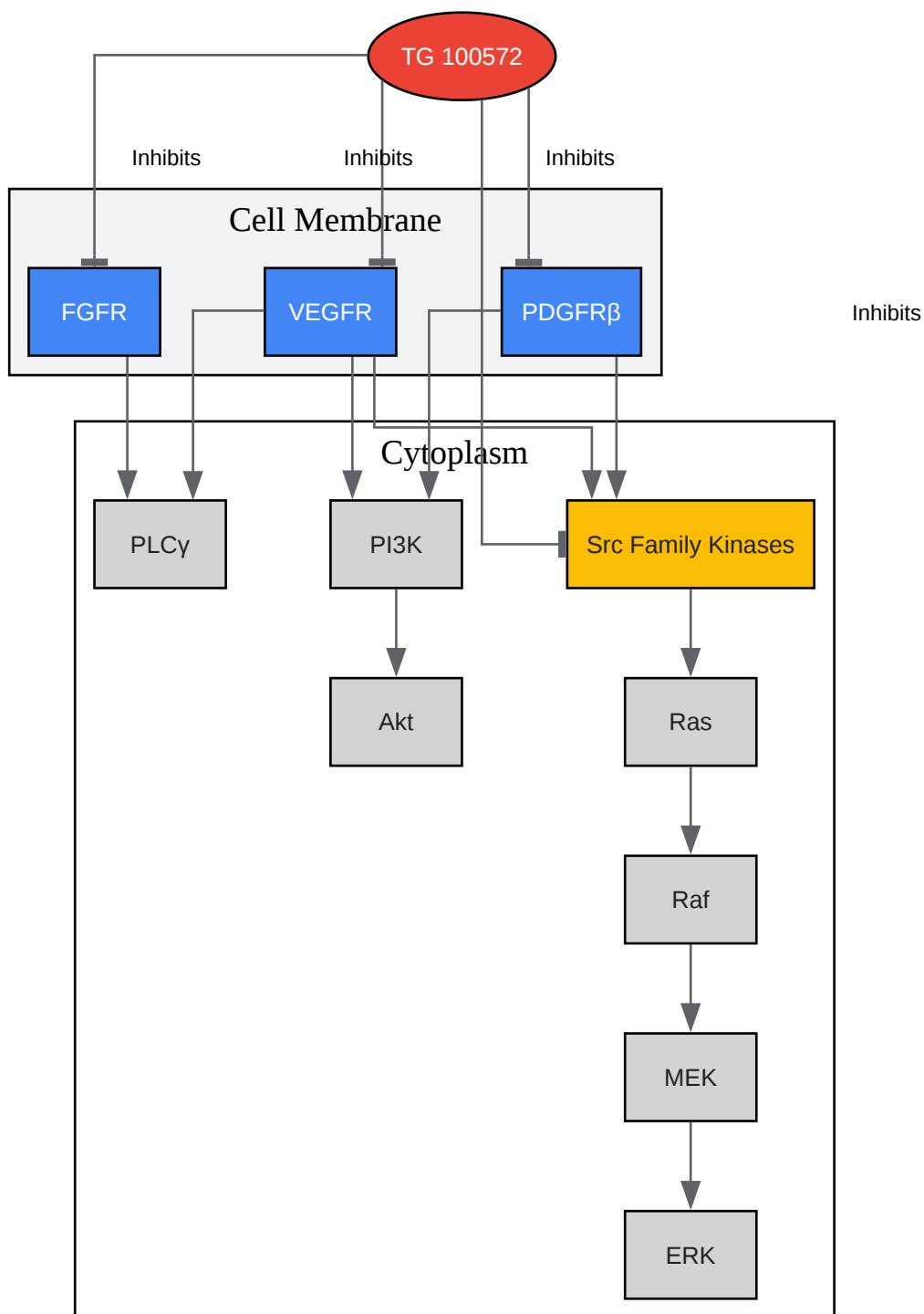

[Click to download full resolution via product page](#)

Caption: Signaling pathways inhibited by TG 100572.

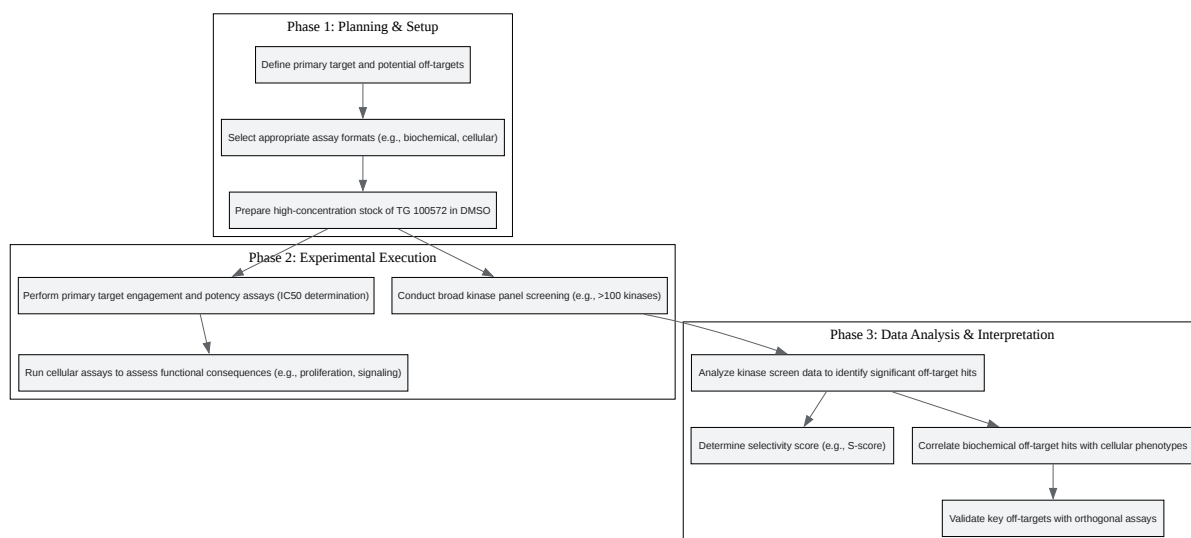

[Click to download full resolution via product page](#)

Caption: Experimental workflow for assessing off-target effects.

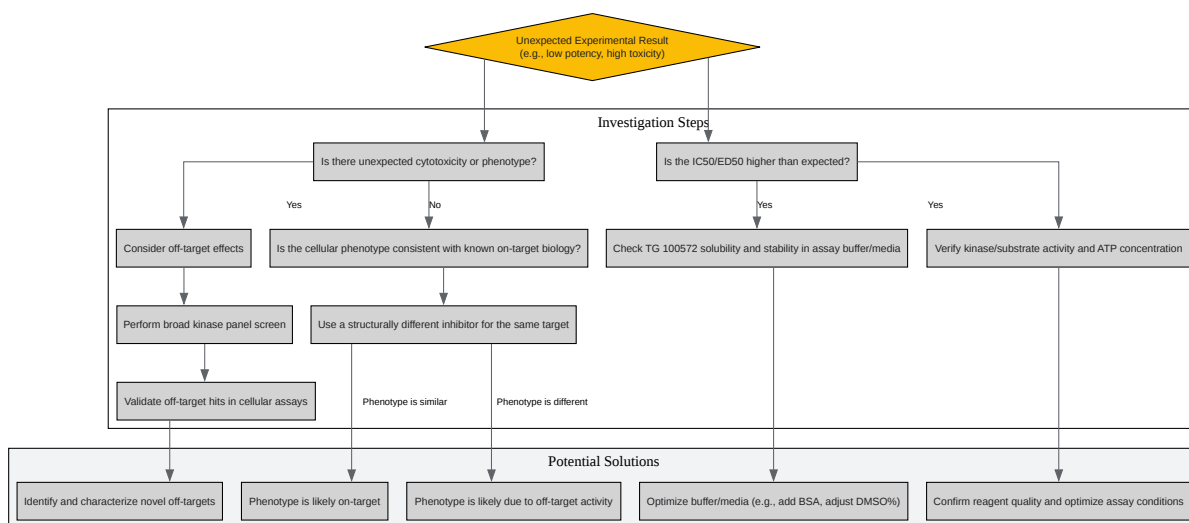

[Click to download full resolution via product page](#)

Caption: Troubleshooting decision tree for unexpected results.

Troubleshooting Guide

Issue	Potential Cause	Recommended Solution
<p>Higher than expected IC50 value in a biochemical assay</p>	<p>1. Compound Instability/Precipitation: TG 100572 may be precipitating in the aqueous assay buffer. 2. Suboptimal Assay Conditions: ATP concentration is too high, leading to competition. Kinase or substrate concentration is incorrect. 3. Degraded Reagents: Kinase has lost activity, or ATP/substrate has degraded.</p>	<p>1. Check the final DMSO concentration (keep it consistent and ideally $\leq 1\%$). Visually inspect for precipitation. Consider adding a carrier protein like BSA (0.01%) to the buffer. 2. Determine the K_m of ATP for your kinase and run the assay at or near the K_m. Titrate the kinase and substrate to ensure the assay is in the linear range. 3. Run a control experiment with a known inhibitor for your target kinase. Use freshly prepared reagents.</p>
<p>Low Potency or No Effect in Cellular Assays</p>	<p>1. Poor Cell Permeability: TG 100572 may not be efficiently entering the cells. 2. Drug Efflux: The compound may be actively transported out of the cells by efflux pumps (e.g., P-gp). 3. High Protein Binding: The compound may bind to serum proteins in the culture medium, reducing its free concentration. 4. Target Not Expressed/Active: The target kinase may not be expressed or basally active in the chosen cell line.</p>	<p>1. While TG 100572 is generally cell-permeable, this can be cell-line dependent. Consider a target engagement assay (e.g., Western blot for phospho-target) to confirm target inhibition within the cell. 2. Test in cell lines with known efflux pump expression or use an efflux pump inhibitor as a control. 3. Perform assays in serum-free or low-serum conditions for a short duration, if possible. 4. Confirm target expression by Western blot or qPCR. If the target requires activation, stimulate the cells with an appropriate growth factor (e.g., VEGF).</p>

Unexpected Cellular Toxicity	<ol style="list-style-type: none">1. On-Target Toxicity: Inhibition of the primary target (e.g., VEGFR) can be toxic to certain cell types that rely on this signaling.2. Off-Target Toxicity: The observed toxicity is due to the inhibition of one or more unintended kinases that are critical for cell survival.	<ol style="list-style-type: none">1. Compare the cytotoxic IC50 with the on-target inhibition IC50. If they are in a similar range, the toxicity may be on-target.2. If toxicity occurs at concentrations significantly different from the on-target IC50, suspect off-target effects. The best approach is to perform a broad kinase screen to identify potential off-targets. A rescue experiment with a drug-resistant mutant of the primary target can also help differentiate on- from off-target effects.
------------------------------	---	--

Variability Between Experiments	<ol style="list-style-type: none">1. Inconsistent Compound Dilutions: Errors in preparing the serial dilutions of TG 100572.2. Cell Passage Number: Cellular responses can change as cells are passaged.3. Reagent Variability: Differences between lots of kinases, substrates, or serum.	<ol style="list-style-type: none">1. Prepare fresh dilutions for each experiment from a well-characterized stock solution.2. Use cells within a defined low passage number range for all experiments.3. Qualify new lots of critical reagents before use in large-scale experiments.
---------------------------------	--	--

Need Custom Synthesis?

BenchChem offers custom synthesis for rare earth carbides and specific isotopic labeling.

Email: info@benchchem.com or [Request Quote Online](#).

References

- 1. [medchemexpress.com](https://www.medchemexpress.com) [[medchemexpress.com](https://www.medchemexpress.com)]

- [2. documents.thermofisher.com \[documents.thermofisher.com\]](https://documents.thermofisher.com)
- [3. Cardiotoxic effects of angiogenesis inhibitors - PubMed \[pubmed.ncbi.nlm.nih.gov\]](https://pubmed.ncbi.nlm.nih.gov)
- [4. Targeting Vascular Endothelial Growth Factor Receptor 2 \(VEGFR-2\): Latest Insights on Synthetic Strategies \[mdpi.com\]](https://mdpi.com)
- To cite this document: BenchChem. [Technical Support Center: TG 100572 In Vitro Applications]. BenchChem, [2026]. [Online PDF]. Available at: [\[https://www.benchchem.com/product/b1682778/docs#technical-support-center-tg-100572-in-vitro-applications\]](https://www.benchchem.com/product/b1682778/docs#technical-support-center-tg-100572-in-vitro-applications)

Disclaimer & Data Validity:

The information provided in this document is for Research Use Only (RUO) and is strictly not intended for diagnostic or therapeutic procedures. While BenchChem strives to provide accurate protocols, we make no warranties, express or implied, regarding the fitness of this product for every specific experimental setup.

Technical Support: The protocols provided are for reference purposes. Unsure if this reagent suits your experiment?

Need Industrial/Bulk Grade? [Request Custom Synthesis Quote](#)

BenchChem

Our mission is to be the trusted global source of essential and advanced chemicals, empowering scientists and researchers to drive progress in science and industry.

Contact

Address: 3281 E Guasti Rd
Ontario, CA 91761, United States
Phone: (601) 213-4426
Email: info@benchchem.com

[Contact our Ph.D. Support Team for a compatibility check](#)

