

# Technical Support Center: Optimizing TG100801 Animal Studies

**Author:** BenchChem Technical Support Team. **Date:** April 2026

## Compound of Interest

Compound Name:	TG 100801
CAS No.:	867331-82-6
Cat. No.:	B1682778

[Get Quote](#)

This technical support center is designed for researchers, scientists, and drug development professionals to minimize variability in animal studies involving the topical ocular administration of TG100801. Below you will find troubleshooting guides and frequently asked questions (FAQs) to address specific issues that may arise during your experiments.

## Frequently Asked Questions (FAQs) & Troubleshooting Guides

This section provides answers to common questions and challenges encountered when working with TG100801 in animal models of ocular disease.

### Formulation and Administration

**Q1:** What is the recommended vehicle for formulating TG100801 for topical ocular administration in animal studies?

**A1:** While specific vehicle compositions are often proprietary, a common approach for preclinical topical ophthalmic formulations involves a sterile, isotonic solution. For the laser-

induced choroidal neovascularization (CNV) model in mice, a simple vehicle such as saline can be used.[1] It is crucial to ensure the formulation is well-tolerated and does not cause ocular irritation. Always include a vehicle-only control group in your study to differentiate any effects of the vehicle from those of TG100801.

Q2: We are observing precipitation of TG100801 in our formulation. What can we do?

A2: TG100801 is a prodrug designed for improved ocular penetration.[2] Solubility issues can arise, leading to inconsistent dosing and potential irritation.

- Troubleshooting Steps:
  - pH Adjustment: Ensure the pH of your vehicle is within a range that maintains the solubility of TG100801.
  - Co-solvents: Consider the use of ophthalmically acceptable co-solvents to improve solubility.
  - Sonication: Gentle sonication can help to dissolve the compound.
  - Fresh Preparation: Prepare the formulation fresh before each use to minimize the chances of precipitation over time.

Q3: What is the appropriate volume of eye drops to administer to mice and rats?

A3: For mice, a volume of 5-10  $\mu$ L per eye is standard.[2] For rats, a slightly larger volume may be used. It is important to be consistent with the volume administered across all animals to reduce variability. Ensure that the drop is administered directly onto the cornea and allow the animal to blink to spread the formulation across the ocular surface.

### Experimental Model and Procedure

Q4: We are seeing high variability in the size of choroidal neovascularization (CNV) lesions in our laser-induced mouse model. What are the potential causes and how can we minimize this?

A4: The laser-induced CNV model is known for its potential for variability.[3][4] Several factors can contribute to this:

- **Laser Parameters:** Inconsistent laser power, duration, or spot size will lead to variable initial injury and subsequent CNV development. It is critical to standardize these parameters. For C57BL/6J mice, a laser power of around 240 mW with a 70 ms duration has been suggested as optimal.[4][5]
- **Bubble Formation:** The formation of a vapor bubble at the time of laser application is a key indicator of the successful rupture of Bruch's membrane. Lesions without bubble formation should be excluded from the analysis.[2]
- **Animal-Related Factors:**
  - **Age and Sex:** Older mice (12-16 weeks) may develop more severe CNV but with greater variation compared to younger mice (6-8 weeks).[4][5] Gender differences in CNV severity may also be more pronounced in older animals.[4][5] Using mice of a consistent age and sex is recommended to reduce variability.
  - **Mouse Strain and Vendor:** The genetic background of the mice can significantly influence the extent of CNV development. It is advisable to source animals from the same vendor for the duration of a study.[3]
- **Post-Laser Complications:** Hemorrhage at the lesion site can affect CNV size and should be a basis for excluding lesions from analysis.[6]

Q5: How can we ensure accurate and consistent evaluation of CNV lesions?

A5: Standardization of the evaluation process is crucial.

- **Imaging:** Use a consistent imaging modality and parameters for all animals.
- **Quantification:** Employ a standardized method for quantifying the CNV area, such as computerized image analysis of fluorescently labeled choroidal flat mounts.[2]
- **Blinding:** The individual quantifying the CNV lesions should be blinded to the treatment groups to avoid bias.
- **Exclusion Criteria:** Establish clear exclusion criteria for lesions (e.g., presence of hemorrhage, inconsistent laser burn) before the study begins and apply them consistently.[1]

[6]

## Efficacy and Toxicity

Q6: We are not observing the expected efficacy of TG100801 in our study. What could be the reasons?

A6: Several factors could contribute to a lack of efficacy:

- Formulation and Dosing:
  - Inadequate Concentration: Ensure the concentration of TG100801 in your formulation is sufficient. Studies have shown efficacy with concentrations ranging from 0.6% to 1% in mice.[2]
  - Dosing Frequency: TG100801 has an ocular half-life of over 7 hours, suggesting that once or twice daily dosing should be sufficient.[7] Ensure your dosing regimen is frequent enough to maintain therapeutic concentrations in the target tissues.
  - Administration Technique: Improper administration of the eye drops can lead to underdosing.
- Prodrug Conversion: TG100801 is a prodrug that is converted to the active metabolite, TG100572, by ocular esterases.[7] While this conversion is generally efficient, factors affecting esterase activity could theoretically influence efficacy.
- Timing of Treatment: The timing of the initiation and duration of treatment relative to the induction of the disease model is critical.

Q7: What are the potential signs of ocular irritation or systemic toxicity to monitor for?

A7: While TG100801 is generally well-tolerated with minimal systemic exposure, it is important to monitor for any adverse effects.[2][7]

- Ocular Irritation:
  - Clinical Signs: Monitor for signs such as blinking, squinting, redness, and discharge.[8] In human studies, mild and transient ocular irritation has been reported.[8]

- Slit-lamp Examination: Regular slit-lamp examinations can provide a more detailed assessment of the ocular surface.
- Systemic Toxicity:
  - Clinical Signs: Monitor for changes in body weight, food and water intake, and overall activity levels. In preclinical studies, no adverse safety signals such as weight loss were observed even with prolonged dosing.[2]
  - Plasma Levels: Systemic exposure to TG100801 and TG100572 following topical administration is typically below the limit of quantitation.[7]

## Data Presentation

Table 1: Kinase Selectivity Profile of TG100572 (Active Metabolite of TG100801)

Kinase Target	IC50 (nM)
VEGF Receptors	
VEGFR1	2
VEGFR2	7
Fibroblast Growth Factor Receptors	
FGFR1	2
FGFR2	16
Platelet-Derived Growth Factor Receptors	
PDGFR $\beta$	13
Src Family Kinases	
Fgr	5
Fyn	0.5
Hck	6
Lck	0.1
Lyn	0.4
Src	1
Yes	0.2

Data compiled from multiple sources.[\[9\]](#)[\[10\]](#)[\[11\]](#)

Table 2: Summary of TG100801 Efficacy in a Murine Laser-Induced CNV Model

Animal Model	TG100801 Concentration	Dosing Regimen	Efficacy Outcome	Reference
C57BL/6 Mice	1%	10 $\mu$ L twice daily for 14 days	58% reduction in CNV area	[2]
C57BL/6 Mice	0.6%	10 $\mu$ L twice daily for 14 days	43% reduction in CNV area (not statistically significant)	[2]
C57BL/6 Mice	5 mg/mL (0.5%)	Three times a day for 14 days	40% reduction in CNV area	[12]

Table 3: Ocular Pharmacokinetics of TG100801 and TG100572

Parameter	Finding	Species	Reference
Ocular Half-life (T <sub>1/2</sub> )	> 7 hours	Mice, Rabbit, Dog, Mini-pig	[7]
Systemic Exposure	Below limit of quantitation (1-3 ng/mL)	Mice, Rabbit, Dog, Mini-pig	[7]
Primary Route of Delivery	Non-corneal (transscleral)	Multiple preclinical species	[7]

## Experimental Protocols

Detailed Methodology for Laser-Induced Choroidal Neovascularization (CNV) and Topical TG100801 Treatment in Mice

This protocol provides a standardized workflow for inducing and evaluating CNV in mice and for the topical administration of TG100801.

- Animal Preparation:
  - Use C57BL/6 mice, aged 6-8 weeks, from a single vendor.[4][5]

- Anesthetize the mice using an appropriate method (e.g., intraperitoneal injection of ketamine/xylazine).
- Dilate the pupils with a topical mydriatic agent (e.g., 1% tropicamide).
- Laser Photocoagulation:
  - Use a green argon laser to deliver four laser spots to each eye, positioned around the optic nerve.
  - Standardize laser parameters (e.g., 50  $\mu\text{m}$  spot size, 0.1 s duration, 150 mW power).[13]
  - Confirm the rupture of Bruch's membrane by the immediate appearance of a vapor bubble.[2][13] Exclude any burns that do not produce a bubble or that cause significant hemorrhage.
- Topical Administration of TG100801:
  - Prepare the TG100801 formulation (e.g., 1% in a sterile saline vehicle) and the vehicle control.
  - Administer a 10  $\mu\text{L}$  drop of the assigned treatment to the cornea of each eye.
  - Follow the predetermined dosing schedule (e.g., twice daily).[2]
- Evaluation of CNV:
  - After the treatment period (e.g., 14 days), humanely euthanize the mice.
  - Enucleate the eyes and prepare choroidal flat mounts.
  - Stain the vasculature with a fluorescent label (e.g., isolectin B4).
  - Capture images of the CNV lesions using fluorescence microscopy.
  - Quantify the area of the CNV lesions using a validated image analysis software. The person performing the quantification should be blinded to the treatment groups.
- Data Analysis:

- Apply pre-defined exclusion criteria for lesions.
- Statistically compare the mean CNV areas between the treatment groups (e.g., using a t-test or ANOVA).

## Mandatory Visualizations

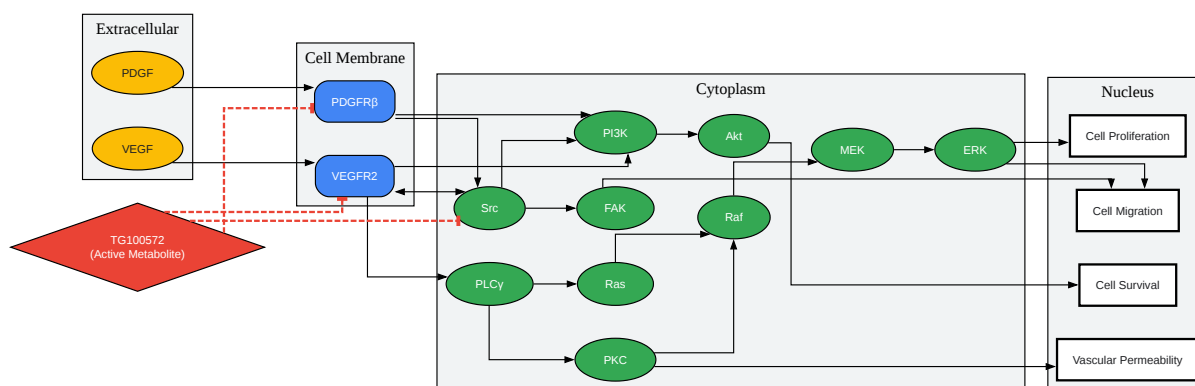

[Click to download full resolution via product page](#)

Caption: Simplified signaling pathway of TG100572 action.

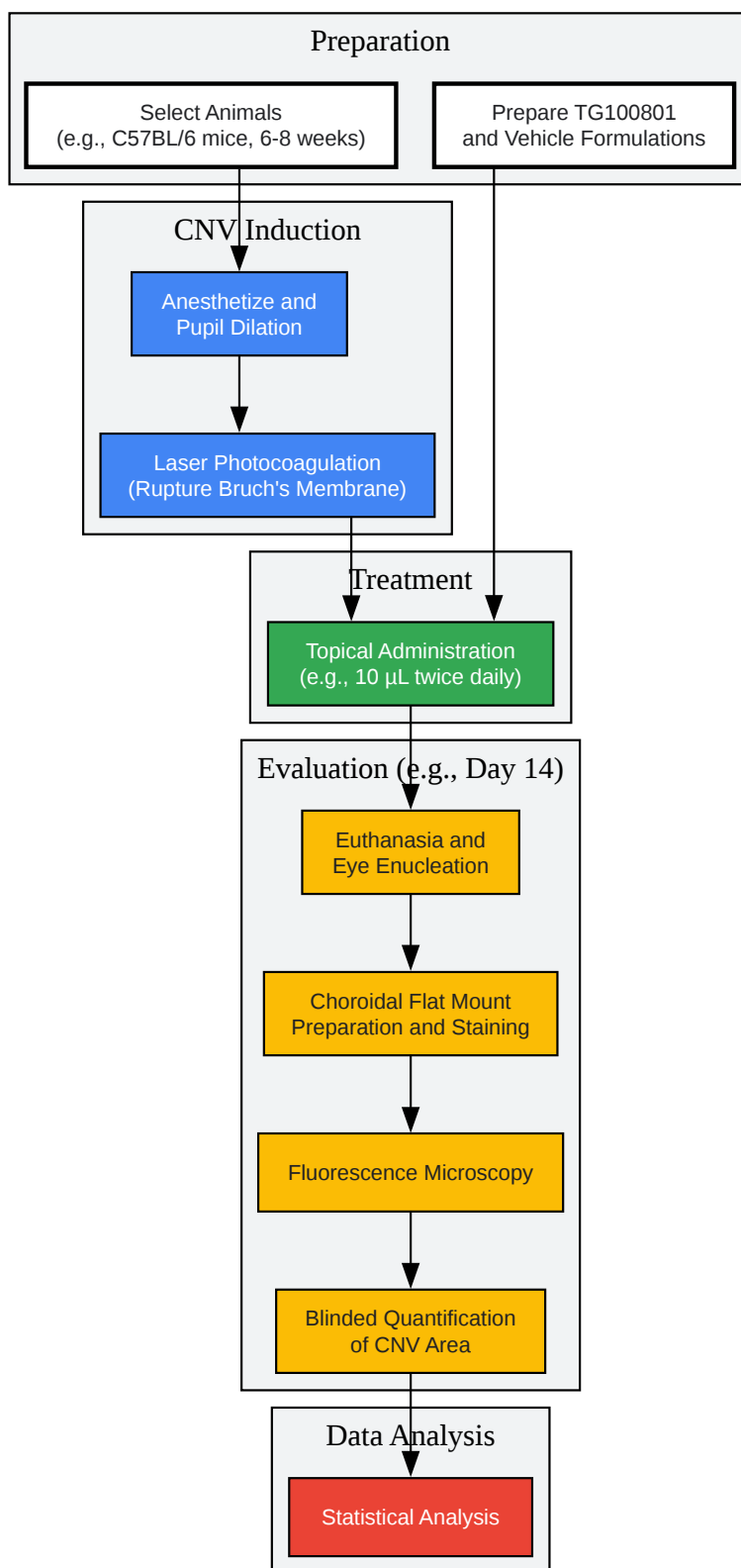

[Click to download full resolution via product page](#)

Caption: Experimental workflow for TG100801 studies.

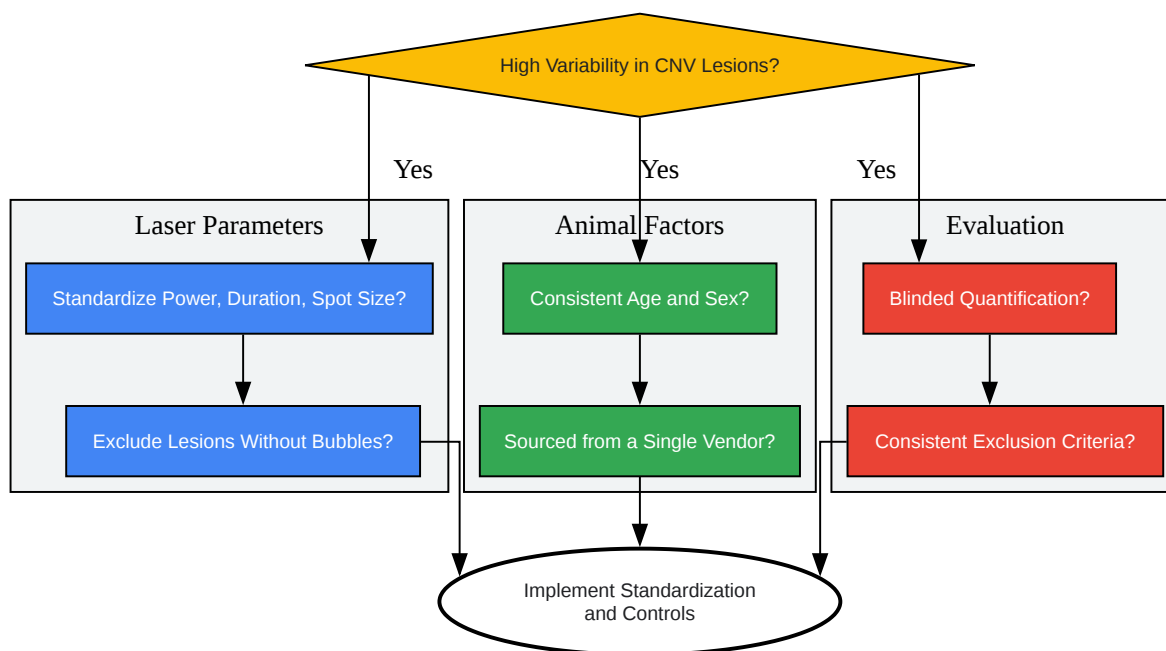

[Click to download full resolution via product page](#)

Caption: Troubleshooting logic for high CNV variability.

**Need Custom Synthesis?**

BenchChem offers custom synthesis for rare earth carbides and specific isotopic labeling.

Email: [info@benchchem.com](mailto:info@benchchem.com) or [Request Quote Online](#).

**References**

- [1. iovs.arvojournals.org \[iovs.arvojournals.org\]](https://iovs.arvojournals.org)
- [2. Topical Administration of a Multi-Targeted Kinase Inhibitor Suppresses Choroidal Neovascularization and Retinal Edema - PMC \[pmc.ncbi.nlm.nih.gov\]](https://pubmed.ncbi.nlm.nih.gov/123456789/)
- [3. iovs.arvojournals.org \[iovs.arvojournals.org\]](https://iovs.arvojournals.org)

- [4. Optimization of an Image-Guided Laser-Induced Choroidal Neovascularization Model in Mice - PMC \[pmc.ncbi.nlm.nih.gov\]](#)
- [5. Optimization of an Image-Guided Laser-Induced Choroidal Neovascularization Model in Mice | PLOS One \[journals.plos.org\]](#)
- [6. youtube.com \[youtube.com\]](#)
- [7. iovs.arvojournals.org \[iovs.arvojournals.org\]](#)
- [8. iovs.arvojournals.org \[iovs.arvojournals.org\]](#)
- [9. medchemexpress.com \[medchemexpress.com\]](#)
- [10. medchemexpress.com \[medchemexpress.com\]](#)
- [11. TG 100572 - Immunomart \[immunomart.com\]](#)
- [12. iovs.arvojournals.org \[iovs.arvojournals.org\]](#)
- [13. orbi.uliege.be \[orbi.uliege.be\]](#)
- To cite this document: BenchChem. [Technical Support Center: Optimizing TG100801 Animal Studies]. BenchChem, [2026]. [Online PDF]. Available at: [\[https://www.benchchem.com/product/b1682778/docs#technical-support-center-optimizing-tg100801-animal-studies\]](https://www.benchchem.com/product/b1682778/docs#technical-support-center-optimizing-tg100801-animal-studies)

---

#### Disclaimer & Data Validity:

The information provided in this document is for Research Use Only (RUO) and is strictly not intended for diagnostic or therapeutic procedures. While BenchChem strives to provide accurate protocols, we make no warranties, express or implied, regarding the fitness of this product for every specific experimental setup.

**Technical Support:** The protocols provided are for reference purposes. Unsure if this reagent suits your experiment?

**Need Industrial/Bulk Grade?** [Request Custom Synthesis Quote](#)

# BenchChem

Our mission is to be the trusted global source of essential and advanced chemicals, empowering scientists and researchers to drive progress in science and industry.

## Contact

Address: 3281 E Guasti Rd

Ontario, CA 91761, United States

Phone: (601) 213-4426

Email: [info@benchchem.com](mailto:info@benchchem.com)

[Contact our Ph.D. Support Team for a compatibility check](#)