

# Technical Support Center: Optimizing Recrystallization of Sucrose Octaacetate

**Author:** BenchChem Technical Support Team. **Date:** April 2026

## Compound of Interest

Compound Name: *D-(+)-Sucrose octaacetate*

CAS No.: 126-14-7

Cat. No.: B1682640

[Get Quote](#)

Welcome to the technical support center for sucrose octaacetate (SOA) purification. As a Senior Application Scientist, my goal is to provide you with in-depth, field-proven insights to overcome common challenges in the recrystallization of this compound. This guide is structured to move from quick-reference materials to deep troubleshooting, ensuring you can find the level of detail you need to succeed in your experiments.

## Section 1: Solvent Selection at a Glance

For experienced researchers, this table provides a rapid overview of common solvents and their suitability for sucrose octaacetate recrystallization. SOA is a largely non-polar molecule due to the esterification of its eight hydroxyl groups, which dictates its solubility profile.<sup>[1]</sup> It is sparingly soluble in water but readily dissolves in many organic solvents.<sup>[2][3][4]</sup>

Table 1: Properties of Potential Recrystallization Solvents for Sucrose Octaacetate

Solvent	Boiling Point (°C)	Polarity (Dielectric Constant)	Suitability for SOA Recrystallization	Comments
Ethanol (95%)	~78	24.6	Excellent (Primary Choice)	SOA is highly soluble in hot ethanol and has low solubility when cold, providing a good temperature coefficient for high recovery. <sup>[5]</sup> <sup>[6]</sup>
Methanol	65	32.6	Good	Lower boiling point can be advantageous for solvent removal. Polarity is slightly higher than ethanol.
Ethanol/Water	Variable	Variable	Excellent (For Fine-Tuning)	A mixed-solvent system useful if SOA is too soluble in pure ethanol. Water acts as an anti-solvent. <sup>[7]</sup>
Toluene	111	2.4	Fair	SOA is soluble. <sup>[2]</sup> <sup>[3]</sup> Higher boiling point may be undesirable and can increase the risk of oiling out.

Ethyl Acetate	77	6.0	Fair to Good	A moderately polar solvent; may require a non-polar anti-solvent like hexane to induce crystallization.
Acetone	56	20.7	Poor (Generally)	SOA is typically too soluble in acetone, even at room temperature, making significant recovery difficult. [3]
Water	100	78.5	Unsuitable (as a primary solvent)	SOA is only slightly soluble in water (0.25 to 1.4 g/L).[2][4] It is, however, an excellent anti-solvent when paired with a soluble solvent like ethanol.
Hexane	69	1.9	Unsuitable (as a primary solvent)	SOA has very low solubility in non-polar alkane solvents. Useful as an anti-solvent.

Note: Solvent property data is compiled from multiple chemical reference sources.[8][9]

## Section 2: Frequently Asked Questions (FAQs)

This section addresses the most common initial questions and problems encountered during the recrystallization of sucrose octaacetate.

Q1: What is the best starting solvent for recrystallizing sucrose octaacetate?

A1: 95% Ethanol is the most widely recommended and effective single solvent.<sup>[5][6]</sup> It provides an excellent balance of properties: SOA dissolves well in hot ethanol but is significantly less soluble at cold temperatures, which is the ideal characteristic for a recrystallization solvent.<sup>[10]</sup>  
<sup>[11]</sup>

Q2: My sucrose octaacetate "oiled out" instead of forming crystals. What happened and how do I fix it?

A2: Oiling out occurs when the dissolved solute comes out of solution at a temperature above its melting point, forming a liquid instead of solid crystals.<sup>[12]</sup> Sucrose octaacetate has a relatively low melting point (one form melts at  $\sim 70^{\circ}\text{C}$ , another more stable form at  $86\text{--}89^{\circ}\text{C}$ ).<sup>[3]</sup>  
<sup>[5]</sup> This can be resolved by:

- Adding more solvent: Add more hot solvent to the oiled-out mixture until the oil fully redissolves. This lowers the saturation point of the solution to a temperature below the compound's melting point.<sup>[12]</sup>
- Slowing the cooling rate: Allow the solution to cool much more gradually. This provides more time for ordered crystal lattice formation instead of amorphous precipitation.
- Using a lower-boiling point solvent: If the problem persists, consider a solvent with a lower boiling point.

Q3: I'm getting a very low yield of crystals. How can I improve recovery?

A3: Low yield is typically caused by one of three factors:

- Using too much solvent: The most common cause. While you need enough hot solvent to dissolve the crude product, an excessive amount will keep too much of your product

dissolved in the mother liquor even after cooling. To fix this, you can evaporate some of the solvent to re-saturate the solution and cool again.

- Incomplete crystallization: Ensure you are cooling the solution for a sufficient amount of time. After slow cooling to room temperature, placing the flask in an ice bath for 15-30 minutes can significantly increase crystal recovery.[12]
- The compound is too soluble: If SOA is too soluble in your chosen solvent (e.g., pure ethanol), you should use a mixed-solvent system. Add a few drops of an "anti-solvent" like water to the hot, dissolved solution to reduce the overall solubility and promote crystallization upon cooling.[13][14]

Q4: No crystals are forming at all, even after cooling in an ice bath. What should I do?

A4: This indicates your solution is "supersaturated" but lacks a nucleation point to begin crystal growth. You can induce crystallization by:

- Scratching the flask: Use a glass rod to gently scratch the inside of the flask below the surface of the liquid. The microscopic imperfections in the glass provide a surface for the first crystals to form.[12]
- Seeding: Add a tiny crystal of pure sucrose octaacetate from a previous batch. This "seed crystal" acts as a template for other molecules to deposit onto, initiating crystallization.[5]
- Reducing the solvent volume: Your solution may be too dilute. Gently heat the solution to boil off some of the solvent, thereby increasing the concentration of the solute, and then attempt to cool it again.

## Section 3: In-Depth Troubleshooting Guide

This guide provides a systematic approach to resolving more complex issues during the optimization process.

### Problem: Persistent Oiling Out

If adding more solvent doesn't resolve the issue, it points to a fundamental mismatch between the solvent's boiling point and the solute's melting point.

- Causality: The solution is becoming saturated at a temperature higher than SOA's melting point.
- Solution Workflow:
  - Re-dissolve: Add more hot solvent to dissolve the oil completely.
  - Introduce an Anti-Solvent: While the solution is still hot, add a miscible anti-solvent (like water for an ethanol solution) dropwise until you see a persistent slight cloudiness (turbidity).[15]
  - Clarify: Add a few drops of the original hot solvent to just re-clarify the solution. This creates a saturated solution at a temperature that is now likely below the melting point of SOA.
  - Cool Slowly: Allow the flask to cool undisturbed to room temperature before moving to an ice bath.

## Problem: Impurities Co-precipitate with the Product (Colored Crystals or Incorrect Melting Point)

This indicates that the chosen solvent does not effectively differentiate between the desired product and the impurities.

- Causality: The impurities have similar solubility characteristics to sucrose octaacetate in your chosen solvent system. According to recrystallization principles, the ideal solvent should dissolve the product when hot but not when cold, while dissolving the impurities at all temperatures or not at all.[11][16]
- Solution Workflow:
  - Perform a Solvent Screen: Test the solubility of your crude material in a range of solvents with varying polarities (e.g., ethanol, ethyl acetate, toluene). The goal is to find a solvent where the product has high solubility at boiling and low solubility at room temperature, while impurities remain in solution.

- Consider a Two-Solvent System: If no single solvent works, a mixed-solvent system is often the solution. Find a "good" solvent that dissolves everything (product and impurities) and a "bad" solvent in which the product is insoluble. Dissolve the crude material in a minimum of the hot "good" solvent, then add the "bad" solvent until precipitation begins. This fine-tuning of polarity can often leave impurities behind in the mother liquor.[12][13]

## Troubleshooting Workflow Diagram

The following diagram illustrates a logical workflow for troubleshooting common recrystallization problems.

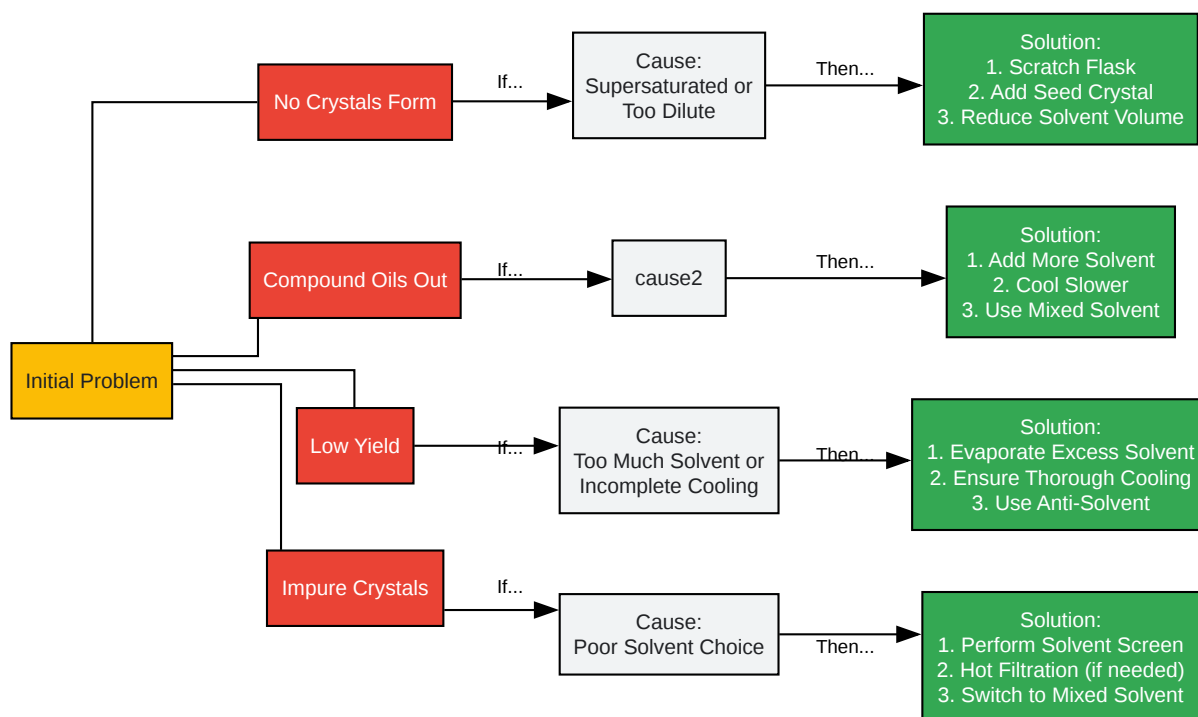

[Click to download full resolution via product page](#)

A troubleshooting flowchart for common recrystallization issues.

## Section 4: Experimental Protocols

These protocols provide step-by-step methodologies for systematically optimizing the recrystallization of sucrose octaacetate.

## Protocol 1: Single-Solvent Recrystallization (Ethanol)

This protocol is based on the common and effective use of 95% ethanol.<sup>[5][17]</sup>

- **Dissolution:** Place the crude sucrose octaacetate (e.g., 1.0 g) into an Erlenmeyer flask. Add a minimal amount of 95% ethanol (e.g., 3-4 mL) and a boiling chip. Heat the mixture gently on a hot plate until it boils.
- **Achieve Saturation:** Continue adding ethanol dropwise while maintaining the boil, just until all the solid material dissolves. Avoid adding a large excess of solvent.
- **Hot Filtration (Optional):** If there are insoluble impurities (e.g., dust, inorganic salts), perform a hot gravity filtration to remove them. This must be done quickly to prevent premature crystallization.
- **Slow Cooling:** Remove the flask from the heat, cover it with a watch glass, and allow it to cool slowly and undisturbed to room temperature. Slow cooling is crucial for forming large, pure crystals.
- **Ice Bath Cooling:** Once the flask has reached room temperature and crystals have formed, place it in an ice-water bath for at least 15-20 minutes to maximize the yield.
- **Collection:** Collect the crystals by vacuum filtration using a Büchner funnel.
- **Washing:** Wash the crystals with a small amount of ice-cold 95% ethanol to remove any adhering mother liquor that contains impurities.
- **Drying:** Allow the crystals to air dry on the filter paper or dry them in a vacuum oven at a low temperature.

## Protocol 2: Mixed-Solvent Recrystallization (Ethanol-Water System)

Use this method when sucrose octaacetate is too soluble in pure ethanol for good recovery.

This is a classic solvent/anti-solvent approach.[\[7\]](#)[\[14\]](#)[\[15\]](#)

- **Dissolution:** In an Erlenmeyer flask, dissolve the crude sucrose octaacetate in the minimum amount of hot 95% ethanol, as described in Protocol 1.
- **Addition of Anti-Solvent:** While keeping the ethanol solution hot, add distilled water (the anti-solvent) drop-by-drop until the solution becomes faintly and persistently cloudy (turbid). This indicates the solution is now saturated.
- **Clarification:** Add 1-2 drops of hot 95% ethanol, just enough to make the solution clear again. The solution is now perfectly saturated at that temperature.
- **Cooling and Collection:** Follow steps 4 through 8 from Protocol 1, using an ice-cold ethanol-water mixture (in the same approximate ratio) for the final wash.

## References

- Sucrose octaacetate - Wikipedia. (n.d.). In Wikipedia. Retrieved March 7, 2026, from [\[Link\]](#)
- Fengchen Group Co., Ltd. (n.d.). Sucrose Octaacetate CAS 126-14-7 Saccharose Octaacetate. Retrieved March 7, 2026, from [\[Link\]](#)
- LookChem. (n.d.). Sucrose Octaacetate|126-14-7. Retrieved March 7, 2026, from [\[Link\]](#)
- Nichols, L. (n.d.). Recrystallization. University of Missouri-St. Louis. Retrieved March 7, 2026, from [\[Link\]](#)
- University of California, Los Angeles. (n.d.). Recrystallization. Retrieved March 7, 2026, from [\[Link\]](#)
- Mann, T. D., Mosher, J. D., & Wood, W. F. (1992). Preparation of sucrose octaacetate-A bitter-tasting compound. *Journal of Chemical Education*, 69(1), 64. Retrieved March 7, 2026, from [\[Link\]](#)
- Mtoz Biolabs. (n.d.). Sucrose Octaacetate Analysis Service. Retrieved March 7, 2026, from [\[Link\]](#)

- University of Wisconsin-Madison. (n.d.). Recrystallization of an Unknown. Retrieved March 7, 2026, from [\[Link\]](#)
- Science Learning Center. (n.d.). Experiment: Recrystallization – Part I: Solvent Selection. Retrieved March 7, 2026, from [\[Link\]](#)
- University of York. (n.d.). Solvent Choice. Chemistry Teaching Labs. Retrieved March 7, 2026, from [\[Link\]](#)
- Schoffstall, A. M. (1971). Solvent Selection for Recrystallization. *Journal of Chemical Education*, 48(10), 703. Retrieved March 7, 2026, from [\[Link\]](#)
- Zhang, L., & Wang, Y. (2012). Preparation of high purity sucrose octaacetate. *Advanced Materials Research*, 550-553, 439-442. Retrieved March 7, 2026, from [\[Link\]](#)
- LibreTexts Chemistry. (2022, April 7). 3.3F: Mixed Solvents. Retrieved March 7, 2026, from [\[Link\]](#)
- Wikipedia. (n.d.). Recrystallization (chemistry). Retrieved March 7, 2026, from [\[Link\]](#)
- University of York. (n.d.). Mixed-solvent recrystallisation. Chemistry Teaching Labs. Retrieved March 7, 2026, from [\[Link\]](#)
- Organic Chemistry Data. (2020, August 9). Common Solvents Used in Organic Chemistry: Table of Properties. Retrieved March 7, 2026, from [\[Link\]](#)
- Murov, S. (n.d.). Common Organic Solvents: Table of Properties. Retrieved March 7, 2026, from [\[Link\]](#)
- Kiper, R. A. (n.d.). Properties of substance: sucrose octaacetate. Retrieved March 7, 2026, from [\[Link\]](#)
- Wood, W. F. (2017). Preparation of Sucrose Octaacetate—A Bitter-Tasting Compound. ResearchGate. Retrieved March 7, 2026, from [\[Link\]](#)
- LibreTexts Chemistry. (2023, January 22). Polar Protic and Aprotic Solvents. Retrieved March 7, 2026, from [\[Link\]](#)

- Petkova, N., et al. (2017). "Green" Synthesis of Sucrose Octaacetate and Characterization of Its Physicochemical Properties and Antimicrobial Activity. *Chemical and Biochemical Engineering Quarterly*, 31(4), 395-402. Retrieved March 7, 2026, from [\[Link\]](#)
- National Center for Biotechnology Information. (n.d.). Sucrose Octaacetate. PubChem Compound Database. Retrieved March 7, 2026, from [\[Link\]](#)
- Petkova, N., et al. (2018). (PDF) "Green" Synthesis of Sucrose Octaacetate and Characterization of Its Physicochemical Properties and Antimicrobial Activity. ResearchGate. Retrieved March 7, 2026, from [\[Link\]](#)

### Need Custom Synthesis?

BenchChem offers custom synthesis for rare earth carbides and specific isotopic labeling.

Email: [info@benchchem.com](mailto:info@benchchem.com) or [Request Quote Online](#).

## Sources

- [1. Page loading... \[wap.guidechem.com\]](#)
- [2. Sucrose octaacetate - Wikipedia \[en.wikipedia.org\]](#)
- [3. Sucrose Octaacetate CAS 126-14-7 Saccharose Octaacetate Manufacturers and Suppliers - Price - Fengchen \[fengchengroup.com\]](#)
- [4. Sucrose octaacetate: Chemical property and uses\\_Chemicalbook \[chemicalbook.com\]](#)
- [5. researchgate.net \[researchgate.net\]](#)
- [6. silverstripe.fkit.hr \[silverstripe.fkit.hr\]](#)
- [7. researchgate.net \[researchgate.net\]](#)
- [8. ce.sysu.edu.cn \[ce.sysu.edu.cn\]](#)
- [9. chem.libretexts.org \[chem.libretexts.org\]](#)
- [10. Recrystallization \[sites.pitt.edu\]](#)
- [11. Chemistry Teaching Labs - Solvent Choice \[chemtl.york.ac.uk\]](#)
- [12. rubingroup.org \[rubingroup.org\]](#)
- [13. web.mnstate.edu \[web.mnstate.edu\]](#)

- [14. chem.libretexts.org \[chem.libretexts.org\]](https://chem.libretexts.org)
- [15. Chemistry Teaching Labs - Mixed-solvents \[chemtl.york.ac.uk\]](https://chemtl.york.ac.uk)
- [16. sciencelearningcenter.pbworks.com \[sciencelearningcenter.pbworks.com\]](https://sciencelearningcenter.pbworks.com)
- [17. researchgate.net \[researchgate.net\]](https://researchgate.net)
- To cite this document: BenchChem. [Technical Support Center: Optimizing Recrystallization of Sucrose Octaacetate]. BenchChem, [2026]. [Online PDF]. Available at: [\[https://www.benchchem.com/product/b1682640/docs#technical-support-center-optimizing-recrystallization-of-sucrose-octaacetate\]](https://www.benchchem.com/product/b1682640/docs#technical-support-center-optimizing-recrystallization-of-sucrose-octaacetate)

---

### Disclaimer & Data Validity:

The information provided in this document is for Research Use Only (RUO) and is strictly not intended for diagnostic or therapeutic procedures. While BenchChem strives to provide accurate protocols, we make no warranties, express or implied, regarding the fitness of this product for every specific experimental setup.

**Technical Support:** The protocols provided are for reference purposes. Unsure if this reagent suits your experiment?

**Need Industrial/Bulk Grade?** [Request Custom Synthesis Quote](#)

## BenchChem

Our mission is to be the trusted global source of essential and advanced chemicals, empowering scientists and researchers to drive progress in science and industry.

### Contact

Address: 3281 E Guasti Rd  
Ontario, CA 91761, United States  
Phone: (601) 213-4426  
Email: [info@benchchem.com](mailto:info@benchchem.com)

[Contact our Ph.D. Support Team for a compatibility check](#)

