

Technical Support Center: Enhancing the Therapeutic Index of Valtrate Derivatives

Author: BenchChem Technical Support Team. **Date:** December 2025

Compound of Interest

Compound Name: Valtrate

Cat. No.: B1682818

[Get Quote](#)

This technical support center provides researchers, scientists, and drug development professionals with comprehensive troubleshooting guides and frequently asked questions (FAQs) for experiments involving **Valtrate** derivatives. Our goal is to facilitate smoother experimental workflows and contribute to the successful enhancement of the therapeutic index of these promising compounds.

Frequently Asked Questions (FAQs)

Q1: What are **Valtrate** derivatives and why is enhancing their therapeutic index important?

A1: **Valtrate** is a natural iridoid compound isolated from the Valeriana species, recognized for its potential as an anti-cancer agent.[1][2] **Valtrate** derivatives are synthetic or semi-synthetic analogues of **Valtrate** designed to improve its pharmacological properties. The therapeutic index, a measure of a drug's safety, is the ratio between its therapeutic and toxic doses. Enhancing this index is crucial to maximize the anti-cancer efficacy of **Valtrate** derivatives while minimizing harmful side effects to healthy tissues.

Q2: What are the known mechanisms of action for **Valtrate** and its derivatives?

A2: **Valtrate** and its derivatives have been shown to exert their anti-cancer effects through multiple mechanisms. Notably, they can inhibit the PDGFRA/MEK/ERK signaling pathway, which is crucial for cell proliferation and survival in cancers like glioblastoma.[3][4] Additionally, **Valtrate** has been found to suppress the Stat3 signaling pathway in pancreatic cancer cells.[5]

These compounds can induce apoptosis (programmed cell death) and cell cycle arrest, and inhibit cancer cell migration.[1][6]

Q3: What are the main challenges encountered when working with **Valtrate** derivatives in the lab?

A3: Common challenges include:

- **Poor aqueous solubility:** **Valtrate** and its derivatives are often lipophilic, leading to difficulties in preparing solutions for in vitro and in vivo experiments.
- **Compound instability:** Valepotriates, the class of compounds to which **Valtrate** belongs, are known to be unstable and can degrade under certain conditions, affecting experimental reproducibility.
- **Inconsistent cytotoxicity results:** Variability in experimental conditions, cell lines, and compound stability can lead to discrepancies in cytotoxicity data.
- **Off-target toxicity:** Achieving selective cytotoxicity against cancer cells while sparing normal cells is a primary hurdle in developing these compounds as therapeutic agents.

Troubleshooting Guides

Issue 1: Inconsistent IC50 values in cytotoxicity assays.

- **Question:** My MTT or other cytotoxicity assays are yielding inconsistent IC50 values for the same **Valtrate** derivative. What could be the cause?
- **Answer:**
 - **Compound Stability:** Valepotriates can degrade in aqueous solutions. Prepare fresh stock solutions in an appropriate solvent (e.g., DMSO) for each experiment and minimize the time the compound is in culture media before and during the assay.
 - **Solubility Issues:** Poor solubility can lead to inaccurate concentrations. Ensure the final solvent concentration in your assay does not exceed a level that is non-toxic to your cells (typically <0.5% DMSO). Visually inspect for any precipitation. Sonication of the stock solution before dilution may help.

- Cell Density: Ensure consistent cell seeding density across all plates and experiments. Variations in cell number can significantly impact metabolic assay readouts.
- Incubation Time: Use a consistent incubation time for drug treatment.
- Assay Interference: Some compounds can interfere with the chemistry of viability assays. Consider using an alternative cytotoxicity assay (e.g., CellTiter-Glo®, which measures ATP levels) to confirm your results.

Issue 2: Difficulty dissolving Valtrate derivatives for in vivo studies.

- Question: I am having trouble preparing a stable and injectable formulation of my **Valtrate** derivative for animal studies. What formulation strategies can I try?
- Answer:
 - Co-solvents: A mixture of solvents can be used to improve solubility. Common systems include combinations of DMSO, polyethylene glycol (PEG), and saline. It is critical to perform preliminary toxicity tests of the vehicle in your animal model.
 - Lipid-based formulations: Encapsulating the derivative in liposomes or nanoemulsions can enhance solubility and improve its pharmacokinetic profile.
 - Polymeric nanoparticles: Formulations using biodegradable polymers like PLGA can encapsulate the drug, potentially improving stability and enabling targeted delivery.
 - Cyclodextrins: These can form inclusion complexes with poorly soluble drugs, increasing their aqueous solubility.

Issue 3: Low or no signal in Western blot for target proteins.

- Question: I am not detecting a change in the phosphorylation of ERK or Stat3 after treating cells with a **Valtrate** derivative. What should I check?
- Answer:

- Treatment Time and Dose: The effect on signaling pathways can be transient. Perform a time-course and dose-response experiment to identify the optimal conditions for observing changes in protein phosphorylation.
- Cell Lysis Conditions: Use lysis buffers containing phosphatase and protease inhibitors to preserve the phosphorylation state of your target proteins.
- Antibody Quality: Ensure your primary antibodies for the phosphorylated and total proteins are validated for Western blotting and are from a reliable source.
- Positive Controls: Include a positive control (e.g., treatment with a known activator of the pathway like PDGF for the PDGFRA/MEK/ERK pathway) to ensure your experimental setup can detect the desired changes.

Data Presentation

Table 1: Cytotoxicity of **Valtrate** Derivatives against Various Cancer Cell Lines

Compound	Cell Line	Assay	IC50 (μM)	Reference
Valtrate	GLC-4 (Lung Cancer)	MTT	1.4	[7]
Valtrate	COLO 320 (Colorectal Cancer)	MTT	3	[7]
Valtrate	MDA-MB-231 (Breast Cancer)	Not Specified	Significant anti-cancer activity	[1][6]
Valtrate	MCF-7 (Breast Cancer)	Not Specified	Significant anti-cancer activity	[1][6]
Valtrate	Glioblastoma (GBM) cells	CCK-8	Significant inhibition of proliferation	[3][4]

Table 2: In Vivo Efficacy of **Valtrate** in a Glioblastoma Xenograft Model

Treatment	Endpoint	Result	Reference
Valtrate	Tumor Volume	Five-fold decrease at day 28 compared to control	[3][4]
Valtrate	Survival	Enhanced survival (day 36 vs. day 27 for control)	[3][4]

Experimental Protocols

MTT Assay for Cytotoxicity

- Cell Seeding: Seed cells in a 96-well plate at a density of 5,000-10,000 cells/well and allow them to adhere overnight.
- Compound Preparation: Prepare a series of dilutions of the **Valtrate** derivative from a concentrated stock solution (e.g., in DMSO). The final DMSO concentration in the wells should be below 0.5%.
- Treatment: Remove the culture medium and add 100 μ L of medium containing the desired concentration of the **Valtrate** derivative to each well. Include vehicle-only controls.
- Incubation: Incubate the plate for the desired treatment duration (e.g., 24, 48, or 72 hours) at 37°C in a humidified incubator with 5% CO₂.
- MTT Addition: Add 10 μ L of MTT solution (5 mg/mL in PBS) to each well and incubate for 3-4 hours at 37°C.
- Formazan Solubilization: Carefully remove the medium and add 100 μ L of DMSO or a solubilization buffer to each well to dissolve the formazan crystals.
- Absorbance Measurement: Measure the absorbance at 570 nm using a microplate reader.
- Data Analysis: Calculate the percentage of cell viability relative to the vehicle control and determine the IC₅₀ value using appropriate software.

Western Blot for PDGFRA/MEK/ERK Pathway

- **Cell Treatment and Lysis:** Treat cells with the **Valtrate** derivative at the desired concentration and time. Wash cells with ice-cold PBS and lyse them in RIPA buffer supplemented with protease and phosphatase inhibitors.
- **Protein Quantification:** Determine the protein concentration of the lysates using a BCA or Bradford assay.
- **SDS-PAGE:** Denature 20-30 µg of protein from each sample by boiling in Laemmli buffer. Separate the proteins on a 10% SDS-polyacrylamide gel.
- **Protein Transfer:** Transfer the separated proteins to a PVDF or nitrocellulose membrane.
- **Blocking:** Block the membrane with 5% non-fat milk or BSA in TBST (Tris-buffered saline with 0.1% Tween 20) for 1 hour at room temperature.
- **Primary Antibody Incubation:** Incubate the membrane with primary antibodies against p-PDGFRA, PDGFRA, p-MEK, MEK, p-ERK, and ERK overnight at 4°C.
- **Secondary Antibody Incubation:** Wash the membrane with TBST and incubate with the appropriate HRP-conjugated secondary antibody for 1 hour at room temperature.
- **Detection:** Visualize the protein bands using an enhanced chemiluminescence (ECL) detection system.
- **Analysis:** Quantify the band intensities and normalize the phosphorylated protein levels to the total protein levels.

Immunofluorescence for STAT3 Nuclear Translocation

- **Cell Culture and Treatment:** Grow cells on glass coverslips in a 24-well plate. Treat with the **Valtrate** derivative as required.
- **Fixation and Permeabilization:** Wash the cells with PBS, fix with 4% paraformaldehyde for 15 minutes, and then permeabilize with 0.25% Triton X-100 in PBS for 10 minutes.
- **Blocking:** Block with 1% BSA in PBST (PBS with 0.1% Tween 20) for 30 minutes.

- **Primary Antibody Incubation:** Incubate with an antibody against STAT3 or phospho-STAT3 overnight at 4°C.
- **Secondary Antibody Incubation:** Wash with PBST and incubate with a fluorescently labeled secondary antibody for 1 hour at room temperature in the dark.
- **Counterstaining and Mounting:** Counterstain the nuclei with DAPI and mount the coverslips on microscope slides.
- **Imaging:** Visualize the cells using a fluorescence microscope and capture images.
- **Analysis:** Assess the subcellular localization of STAT3. An increase in nuclear fluorescence indicates activation and translocation.

Mandatory Visualizations

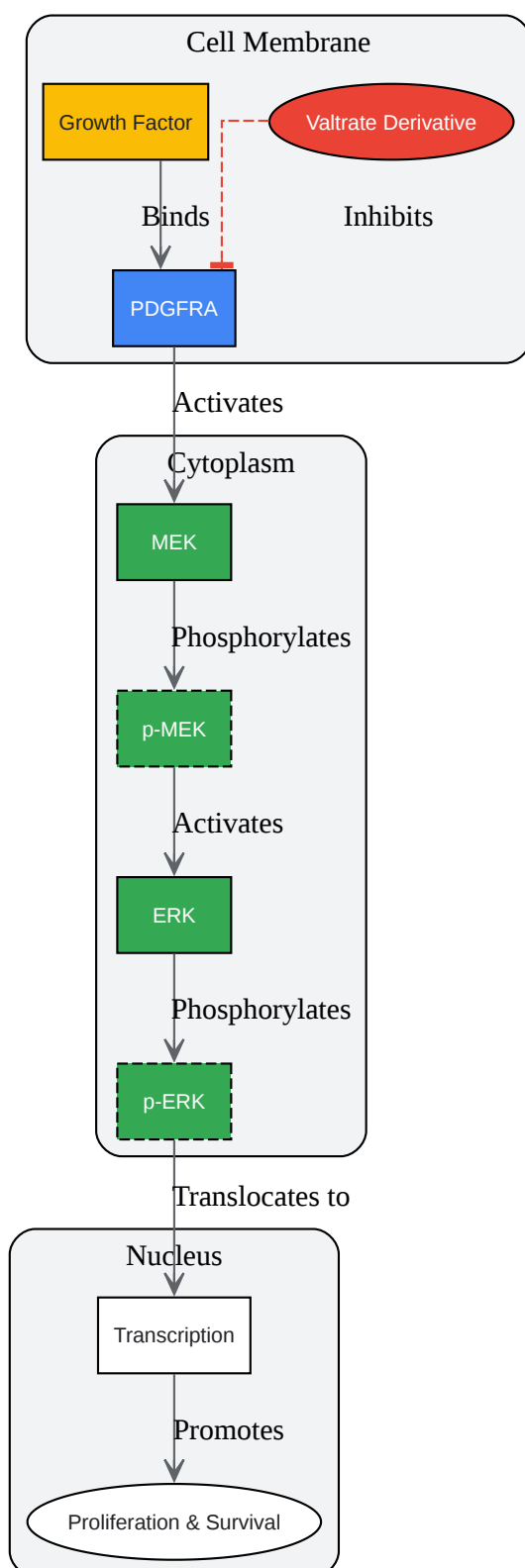

[Click to download full resolution via product page](#)

Caption: PDGFRA/MEK/ERK Signaling Pathway Inhibition by **Valtrate** Derivatives.

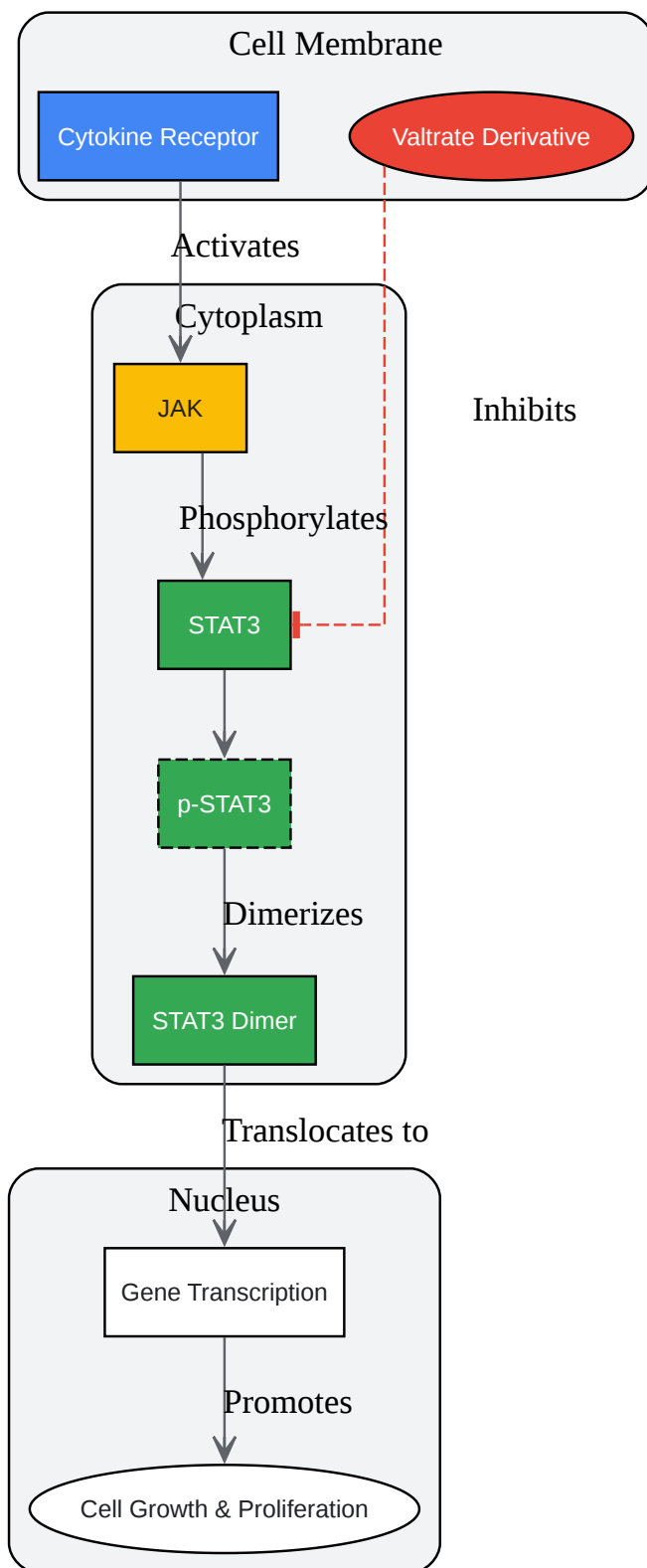

[Click to download full resolution via product page](#)

Caption: STAT3 Signaling Pathway Inhibition by **Valtrate** Derivatives.

Caption: Experimental Workflow for MTT Cytotoxicity Assay.

Need Custom Synthesis?

BenchChem offers custom synthesis for rare earth carbides and specific isotopic labeling.

Email: info@benchchem.com or [Request Quote Online](#).

References

- 1. Valtrate from Valeriana jatamansi Jones induces apoptosis and inhibits migration of human breast cancer cells in vitro - PubMed [pubmed.ncbi.nlm.nih.gov]
- 2. researchgate.net [researchgate.net]
- 3. Valtrate, an iridoid compound in Valeriana, elicits anti-glioblastoma activity through inhibition of the PDGFRA/MEK/ERK signaling pathway - PubMed [pubmed.ncbi.nlm.nih.gov]
- 4. Valtrate, an iridoid compound in Valeriana, elicits anti-glioblastoma activity through inhibition of the PDGFRA/MEK/ERK signaling pathway - PMC [pmc.ncbi.nlm.nih.gov]
- 5. researchgate.net [researchgate.net]
- 6. researchgate.net [researchgate.net]
- 7. caymanchem.com [caymanchem.com]
- To cite this document: BenchChem. [Technical Support Center: Enhancing the Therapeutic Index of Valtrate Derivatives]. BenchChem, [2025]. [Online PDF]. Available at: [https://www.benchchem.com/product/b1682818#enhancing-the-therapeutic-index-of-valtrate-derivatives]

Disclaimer & Data Validity:

The information provided in this document is for Research Use Only (RUO) and is strictly not intended for diagnostic or therapeutic procedures. While BenchChem strives to provide accurate protocols, we make no warranties, express or implied, regarding the fitness of this product for every specific experimental setup.

Technical Support: The protocols provided are for reference purposes. Unsure if this reagent suits your experiment? [[Contact our Ph.D. Support Team for a compatibility check](#)]

Need Industrial/Bulk Grade? [Request Custom Synthesis Quote](#)

BenchChem

Our mission is to be the trusted global source of essential and advanced chemicals, empowering scientists and researchers to drive progress in science and industry.

Contact

Address: 3281 E Guasti Rd
Ontario, CA 91761, United States
Phone: (601) 213-4426
Email: info@benchchem.com