

# TGX-155 in Thrombosis Models: A Technical Guide

**Author:** BenchChem Technical Support Team. **Date:** April 2026

## Compound of Interest

Compound Name:	TGX-155
CAS No.:	351071-90-4
Cat. No.:	B1682241

[Get Quote](#)

For Researchers, Scientists, and Drug Development Professionals

## Executive Summary

**TGX-155**, a selective inhibitor of phosphoinositide 3-kinase  $\beta$  (PI3K $\beta$ ), has emerged as a promising candidate in the development of novel antithrombotic therapies. Pathological thrombus formation is a critical factor in a multitude of cardiovascular diseases. Current antithrombotic treatments, while effective, are often associated with significant bleeding risks due to their impact on normal hemostasis. A key therapeutic goal is to selectively target pathways crucial for pathological thrombus formation without compromising hemostasis. **TGX-155** shows potential in this area by targeting PI3K $\beta$ , an enzyme that plays a significant role in platelet activation and thrombus stabilization, particularly under conditions of high shear stress characteristic of arterial thrombosis. This document provides a comprehensive overview of the preclinical data on **TGX-155** in various thrombosis models, details the experimental protocols used for its evaluation, and illustrates the key signaling pathways involved.

# Introduction to TGX-155 and its Mechanism of Action

**TGX-155** is a potent and selective inhibitor of the p110 $\beta$  catalytic subunit of Class IA phosphoinositide 3-kinases (PI3Ks). The PI3K family of enzymes is crucial in regulating a wide array of cellular functions, including cell growth, proliferation, differentiation, motility, and survival. In platelets, the PI3K $\beta$  isoform is highly expressed and plays a pivotal role in intracellular signaling downstream of various platelet surface receptors, including G protein-coupled receptors (GPCRs) for agonists like ADP and thrombin, and the glycoprotein VI (GPVI) receptor for collagen.

Activation of PI3K $\beta$  leads to the phosphorylation of phosphatidylinositol 4,5-bisphosphate (PIP<sub>2</sub>) to generate phosphatidylinositol 3,4,5-trisphosphate (PIP<sub>3</sub>). PIP<sub>3</sub> acts as a second messenger, recruiting and activating downstream effectors such as the serine/threonine kinase Akt (also known as protein kinase B). The PI3K $\beta$ /Akt signaling cascade is integral to the processes of platelet adhesion, activation, and aggregation, which are fundamental to thrombus formation. By selectively inhibiting PI3K $\beta$ , **TGX-155** can disrupt these signaling pathways, thereby reducing platelet-driven thrombus formation.

## Quantitative Data on TGX-155 Efficacy

The preclinical efficacy of **TGX-155** has been evaluated in a variety of in vitro and in vivo models of thrombosis. The following tables summarize the key quantitative findings.

### Table 1: In Vitro Efficacy of TGX-155 on Platelet Aggregation

Agonist	Species	Assay	TGX-155 Concentration	Endpoint	Result
Convulxin (GPVI agonist)	Human	Platelet Aggregation	500 nM	Inhibition of Aggregation	Significant inhibition
Convulxin (GPVI agonist)	Human	Dense Granule Secretion	500 nM	Inhibition of ATP Release	Significant inhibition

Note: Data for **TGX-155** on platelet aggregation induced by common agonists such as ADP and collagen is not readily available in the public domain. The data presented is for TGX-221, a closely related and well-studied PI3K $\beta$  inhibitor, to provide an indication of the expected efficacy.<sup>[1]</sup>

## Table 2: In Vivo Efficacy of TGX-155 in Thrombosis Models

Model	Species	TGX-155 Dose	Endpoint	Result
Carotid Artery Injury (Folts Model)	Rabbit	1.5 mg/kg (i.v.)	Cyclic Flow Reductions (CFRs)	Significant improvement (time and dose-dependent) <sup>[2]</sup>
Carotid Artery Injury (Folts Model)	Rabbit	2.5 mg/kg (i.v.)	Cyclic Flow Reductions (CFRs)	Significant improvement (time and dose-dependent) <sup>[2]</sup>

Note: Specific quantitative data on the percentage improvement of CFRs, or effects on thrombus weight and occlusion time in other models, are not detailed in the currently available literature.

## Table 3: Effect of TGX-155 on Bleeding Time

Species	TGX-155 Dose	Endpoint	Result
N/A	N/A	Bleeding Time	Data not available in the public domain

Note: While PI3K $\beta$  inhibition is hypothesized to have a minimal effect on normal hemostasis, specific dose-response data for **TGX-155** on bleeding time is not currently available in the public literature.

## Experimental Protocols

### Ferric Chloride (FeCl<sub>3</sub>)-Induced Carotid Artery Thrombosis Model in Mice

This model is widely used to study arterial thrombosis and evaluate the efficacy of antithrombotic agents.

Materials:

- Male C57BL/6 mice (8-12 weeks old)
- Anesthetic (e.g., ketamine/xylazine cocktail)
- Surgical microscope
- Micro-surgical instruments (forceps, scissors)
- Doppler flow probe
- FeCl<sub>3</sub> solution (e.g., 10% in distilled water)
- Filter paper (1x2 mm strips)
- Saline solution

Procedure:

- Anesthetize the mouse via intraperitoneal injection and confirm the depth of anesthesia.

- Place the mouse in a supine position on a heating pad to maintain body temperature.
- Make a midline cervical incision to expose the trachea and surrounding muscles.
- Gently dissect the soft tissues to isolate the common carotid artery.
- Place a Doppler flow probe around the artery to monitor blood flow.
- Apply a small piece of filter paper saturated with  $\text{FeCl}_3$  solution to the adventitial surface of the carotid artery for a defined period (e.g., 3 minutes).
- Remove the filter paper and rinse the area with saline.
- Continuously monitor blood flow until complete occlusion occurs or for a predetermined observation period.
- The primary endpoint is the time to vessel occlusion. Thrombus weight can also be measured post-euthanasia.

## Folts Model of Cyclic Flow Reductions in Rabbit Carotid Artery

This model simulates the dynamic process of thrombus formation and embolization at a site of arterial stenosis and endothelial injury.

Materials:

- New Zealand White rabbits
- Anesthetic (e.g., ketamine/xylazine)
- Surgical microscope
- Micro-surgical instruments
- Electromagnetic flow probe
- Vessel occluder or silk suture

- Forceps

Procedure:

- Anesthetize the rabbit and maintain anesthesia throughout the procedure.
- Isolate a segment of the carotid artery.
- Place an electromagnetic flow probe around the artery to measure blood flow.
- Induce a critical stenosis by placing a vessel occluder or tying a silk suture around the artery, typically reducing blood flow by about 50%.
- Induce endothelial injury at the site of stenosis by gently pinching the artery with forceps.
- Observe the blood flow pattern for the development of cyclic flow reductions (CFRs), which represent the formation and subsequent embolization of platelet-rich thrombi.
- After a baseline period of stable CFRs, administer the test compound (e.g., **TGX-155**) and monitor the changes in the frequency and severity of the CFRs.

## Signaling Pathways and Visualizations

### PI3K $\beta$ /Akt Signaling Pathway in Platelets

The following diagram illustrates the central role of PI3K $\beta$  in platelet activation downstream of key receptors.

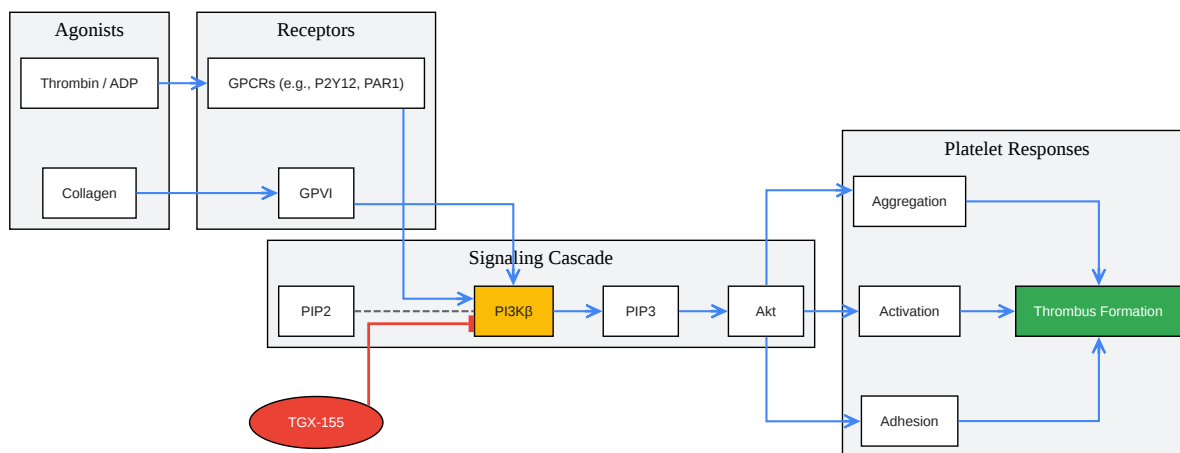

[Click to download full resolution via product page](#)

Caption: PI3Kβ signaling cascade in platelet activation.

## Experimental Workflow for In Vivo Thrombosis Model

The following diagram outlines the typical workflow for evaluating an antithrombotic agent in an in vivo thrombosis model.

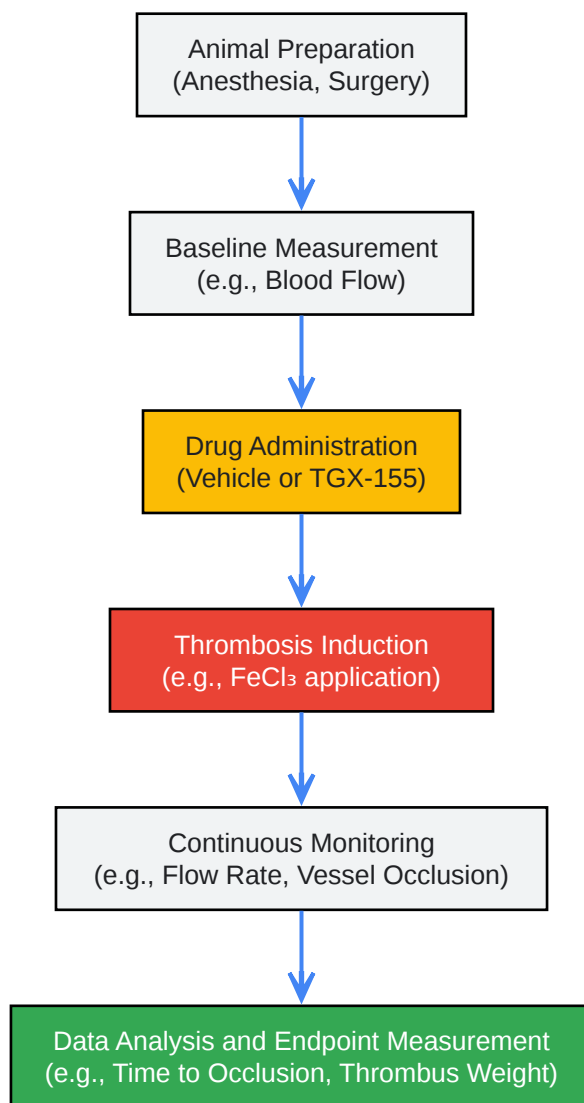

[Click to download full resolution via product page](#)

Caption: Workflow for in vivo thrombosis model.

## Discussion and Future Directions

The available preclinical data suggests that **TGX-155**, through its selective inhibition of PI3K $\beta$ , effectively reduces arterial thrombus formation in animal models. The mechanism of action, targeting a key signaling node in platelet activation, provides a strong rationale for its potential as an antithrombotic agent. The observation that PI3K $\beta$  is particularly important for thrombus stability under high shear stress further supports its development for the prevention and treatment of arterial thrombosis, such as in myocardial infarction and ischemic stroke.

However, a comprehensive evaluation of **TGX-155** requires further investigation. Key areas for future research include:

- **Quantitative Dose-Response Studies:** Detailed in vitro studies are needed to determine the IC50 of **TGX-155** against platelet aggregation induced by a range of agonists (ADP, collagen, thrombin) in both human and relevant animal species.
- **In Vivo Efficacy in Diverse Models:** The antithrombotic effects of **TGX-155** should be quantified in various thrombosis models, including venous thrombosis models, to fully characterize its therapeutic potential.
- **Bleeding Risk Assessment:** Rigorous dose-ranging studies are essential to determine the therapeutic window of **TGX-155** and to confirm the hypothesis that selective PI3K $\beta$  inhibition is associated with a lower bleeding risk compared to current standard-of-care antithrombotic agents.
- **Combination Therapy:** Investigating the potential synergistic effects of **TGX-155** with other antiplatelet or anticoagulant drugs could lead to more effective and safer antithrombotic regimens.

In conclusion, **TGX-155** represents a promising targeted approach for antithrombotic therapy. Its selectivity for PI3K $\beta$  offers the potential for a safer side-effect profile, particularly concerning bleeding. Further preclinical and clinical studies are warranted to fully elucidate its therapeutic utility in the management of thrombotic disorders.

#### *Need Custom Synthesis?*

*BenchChem offers custom synthesis for rare earth carbides and specific isotopic labeling.*

*Email: [info@benchchem.com](mailto:info@benchchem.com) or [Request Quote Online](#).*

## References

- [1. researchgate.net \[researchgate.net\]](https://www.researchgate.net)
- [2. medchemexpress.com \[medchemexpress.com\]](https://www.medchemexpress.com)

- To cite this document: BenchChem. [TGX-155 in Thrombosis Models: A Technical Guide]. BenchChem, [2026]. [Online PDF]. Available at: [<https://www.benchchem.com/product/b1682241/docs#tgx-155-in-thrombosis-models-a-technical-guide>]

---

### Disclaimer & Data Validity:

The information provided in this document is for Research Use Only (RUO) and is strictly not intended for diagnostic or therapeutic procedures. While BenchChem strives to provide accurate protocols, we make no warranties, express or implied, regarding the fitness of this product for every specific experimental setup.

**Technical Support:** The protocols provided are for reference purposes. Unsure if this reagent suits your experiment?

**Need Industrial/Bulk Grade?** [Request Custom Synthesis Quote](#)

## BenchChem

Our mission is to be the trusted global source of essential and advanced chemicals, empowering scientists and researchers to drive progress in science and industry.

### Contact

Address: 3281 E Guasti Rd  
Ontario, CA 91761, United States  
Phone: (601) 213-4426  
Email: [info@benchchem.com](mailto:info@benchchem.com)

[Contact our Ph.D. Support Team for a compatibility check](#)