

# Application Notes and Protocols for TCS 1102 in Conditioned Place Preference Studies

**Author:** BenchChem Technical Support Team. **Date:** April 2026

## Compound of Interest

Compound Name: TCS 1102

Cat. No.: B1682611

[Get Quote](#)

For Researchers, Scientists, and Drug Development Professionals

## Introduction

**TCS 1102** is a potent and selective dual orexin receptor antagonist (DORA) with high affinity for both the orexin-1 (OX1R) and orexin-2 (OX2R) receptors. The orexin system, also known as the hypocretin system, is a key regulator of several physiological functions, including wakefulness, feeding behavior, and reward processing. Due to its role in the modulation of reward pathways, the orexin system has emerged as a significant target for investigating the neurobiology of addiction. Conditioned Place Preference (CPP) is a widely used preclinical behavioral paradigm to study the rewarding and reinforcing properties of drugs of abuse. These application notes provide detailed protocols for the use of **TCS 1102** in CPP studies to investigate the involvement of the orexin system in drug-seeking behavior.

## Mechanism of Action of TCS 1102

**TCS 1102** acts as a competitive antagonist at both OX1 and OX2 receptors, thereby blocking the downstream signaling cascades initiated by the binding of the endogenous orexin peptides, orexin-A and orexin-B. Orexin receptors are G-protein coupled receptors (GPCRs). OX1R couples exclusively to the Gq subclass of G-proteins, while OX2R can couple to Gq, Gi/o, and

Gs proteins. Activation of these pathways typically leads to an increase in intracellular calcium levels and neuronal excitability. By inhibiting these signaling pathways, **TCS 1102** can effectively attenuate the physiological and behavioral responses mediated by the orexin system.

## Orexin Receptor Signaling Pathway

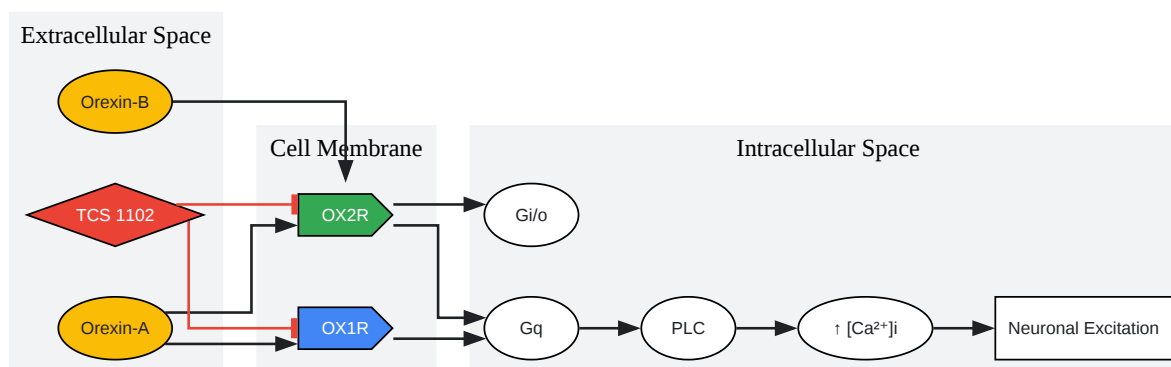

[Click to download full resolution via product page](#)

**Caption:** Orexin receptor signaling and **TCS 1102** inhibition.

## Data Presentation

Quantitative data from CPP studies should be presented in a clear and organized manner to facilitate comparison between experimental groups. The following table provides a template with hypothetical data illustrating the potential effect of **TCS 1102** on morphine-induced CPP in mice. The primary measure is the "CPP Score," calculated as the time spent in the drug-paired chamber during the post-conditioning test minus the time spent in the same chamber during the pre-conditioning (baseline) test.

Treatment Group	Drug Pairing	Pre-Conditioning Time in Paired Chamber (s) (Mean ± SEM)	Post-Conditioning Time in Paired Chamber (s) (Mean ± SEM)	CPP Score (s) (Mean ± SEM)
Vehicle + Saline	Saline	445 ± 25	450 ± 28	5 ± 15
Vehicle + Morphine	Morphine (10 mg/kg)	452 ± 30	750 ± 45	298 ± 38
TCS 1102 + Saline	Saline	448 ± 28	455 ± 32	7 ± 18
TCS 1102 + Morphine	Morphine (10 mg/kg)	455 ± 26	465 ± 35	10 ± 22#

$p < 0.05$   
 compared to  
 Vehicle + Saline  
 group. # $p < 0.05$   
 compared to  
 Vehicle +  
 Morphine group.  
 (Note: Data are  
 hypothetical for  
 illustrative  
 purposes).

## Experimental Protocols

The following protocols are adapted from established methodologies for conditioned place preference studies.

### Protocol 1: Evaluating the Effect of TCS 1102 on the Acquisition of Morphine-Induced CPP

This protocol is designed to determine if **TCS 1102** can block the development of a preference for an environment associated with morphine reward.

## Materials:

- **TCS 1102** (Tocris Bioscience or equivalent)
- Morphine hydrochloride
- Sterile saline (0.9% NaCl)
- Vehicle for **TCS 1102** (e.g., 10% DMSO, 40% PEG300, 5% Tween-80, 45% Saline)
- Adult male C57BL/6J mice (8-10 weeks old)
- Conditioned Place Preference (CPP) apparatus (e.g., a three-chamber box with distinct visual and tactile cues in the two outer chambers)
- Animal scale
- Syringes and needles for intraperitoneal (i.p.) injection

## Experimental Workflow:

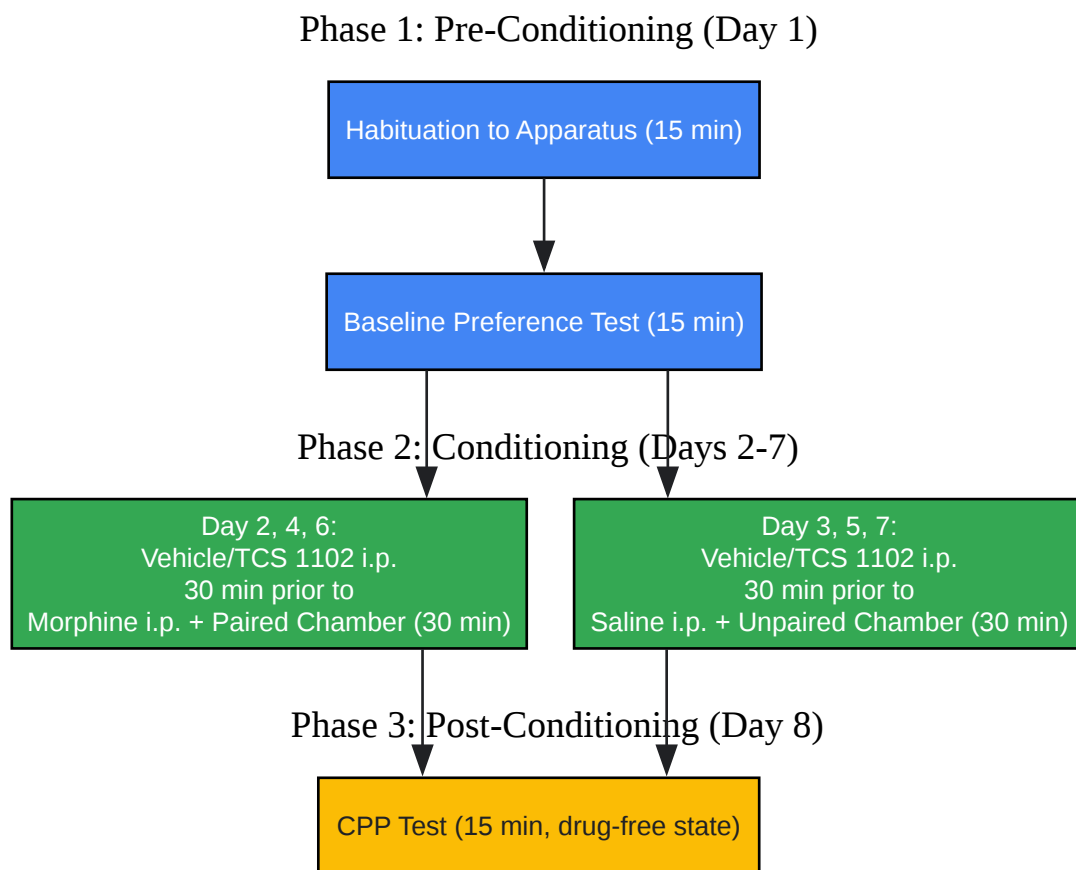

[Click to download full resolution via product page](#)

**Caption:** Experimental workflow for a CPP study.

Procedure:

- Habituation and Pre-Conditioning (Day 1):
  1. Handle the mice for 2-3 minutes each day for 3 days prior to the start of the experiment.
  2. On Day 1, place each mouse in the central chamber of the CPP apparatus and allow free access to all chambers for 15 minutes.
  3. Record the time spent in each of the two outer chambers to establish baseline preference. An unbiased design is recommended, where the drug is paired with the initially non-preferred side for half of the animals and the preferred side for the other half.

- Conditioning (Days 2-7):
  1. Divide the animals into four groups: Vehicle + Saline, Vehicle + Morphine, **TCS 1102** + Saline, and **TCS 1102** + Morphine.
  2. On conditioning days, administer **TCS 1102** (e.g., 20 mg/kg, i.p.) or its vehicle 30 minutes before the morphine or saline injection.
  3. On Days 2, 4, and 6, administer morphine (e.g., 10 mg/kg, i.p.) and immediately confine the mouse to the designated "drug-paired" chamber for 30 minutes.
  4. On Days 3, 5, and 7, administer saline (i.p.) and immediately confine the mouse to the opposite "saline-paired" chamber for 30 minutes. The order of morphine and saline conditioning days should be counterbalanced across animals.
- Post-Conditioning Test (Day 8):
  1. One day after the last conditioning session, place each mouse in the central chamber of the CPP apparatus with free access to all chambers for 15 minutes in a drug-free state.
  2. Record the time spent in each of the outer chambers.
  3. Calculate the CPP score for each animal.

## Protocol 2: Evaluating the Effect of TCS 1102 on the Expression of Cocaine-Induced CPP

This protocol is designed to determine if **TCS 1102** can block the expression of a previously established preference for an environment associated with cocaine reward.

Materials:

- **TCS 1102**
- Cocaine hydrochloride
- Sterile saline (0.9% NaCl)

- Vehicle for **TCS 1102**
- Adult male Sprague-Dawley rats (250-300 g)
- CPP apparatus
- Animal scale
- Syringes and needles for i.p. injection

Procedure:

- Habituation and Pre-Conditioning (Day 1):
  - Follow the same procedure as in Protocol 1.
- Conditioning (Days 2-7):
  1. Divide the animals into two main groups: one to be conditioned with cocaine and one with saline.
  2. On Days 2, 4, and 6, administer cocaine (e.g., 15 mg/kg, i.p.) and confine the rat to the drug-paired chamber for 30 minutes.
  3. On Days 3, 5, and 7, administer saline (i.p.) and confine the rat to the saline-paired chamber for 30 minutes.
- Post-Conditioning Test (Day 8):
  1. One day after the last conditioning session, further divide the cocaine-conditioned rats into two subgroups: one to receive vehicle and the other to receive **TCS 1102**.
  2. Administer **TCS 1102** (e.g., 10 mg/kg, i.p.) or its vehicle 30 minutes before the CPP test.
  3. Place each rat in the central chamber with free access to all chambers for 15 minutes.
  4. Record the time spent in each of the outer chambers and calculate the CPP score.

Disclaimer: These protocols provide a general framework. The optimal doses of **TCS 1102** and the drug of abuse, as well as the specific timings and conditioning schedules, may need to be optimized based on the specific research question, animal strain, and laboratory conditions. All animal procedures should be conducted in accordance with institutional and national guidelines for animal care and use.

- To cite this document: BenchChem. [Application Notes and Protocols for TCS 1102 in Conditioned Place Preference Studies]. BenchChem, [2026]. [Online PDF]. Available at: [<https://www.benchchem.com/product/b1682611/docs#application-notes-and-protocols-for-tcs-1102-in-conditioned-place-preference-studies>]

---

### Disclaimer & Data Validity:

The information provided in this document is for Research Use Only (RUO) and is strictly not intended for diagnostic or therapeutic procedures. While BenchChem strives to provide accurate protocols, we make no warranties, express or implied, regarding the fitness of this product for every specific experimental setup.

**Technical Support:** The protocols provided are for reference purposes. Unsure if this reagent suits your experiment?

**Need Industrial/Bulk Grade?** [Request Custom Synthesis Quote](#)

## BenchChem

Our mission is to be the trusted global source of essential and advanced chemicals, empowering scientists and researchers to drive progress in science and industry.

### Contact

Address: 3281 E Guasti Rd  
Ontario, CA 91761, United States  
Phone: (601) 213-4426  
Email: [info@benchchem.com](mailto:info@benchchem.com)

Contact our Ph.D. Support Team for a compatibility check