

# Technical Monograph: Sarasinoside C1 – Chemical Architecture, Isolation, and Bioactivity Profile

**Author:** BenchChem Technical Support Team. **Date:** May 2026

## Compound of Interest

Compound Name:	Sarasinoside C1
CAS No.:	114066-51-2
Cat. No.:	B1680772

[Get Quote](#)

## Executive Summary

**Sarasinoside C1** is a marine-derived triterpenoid oligoglycoside (saponin) belonging to the 30-norlanostane class.<sup>[1][2]</sup> First isolated from the sponge *Melophlus sarasinorum* (formerly *Asteropus sarasinorum*), it represents a distinct chemical scaffold characterized by a complex branched tetraose moiety linked to a steroidal aglycone.<sup>[1]</sup>

This guide provides a rigorous analysis of **Sarasinoside C1**, synthesizing physicochemical properties, extraction methodologies, and pharmacological potential.<sup>[1]</sup> It is designed to serve as a reference for medicinal chemists and pharmacologists investigating marine natural products for cytotoxic and antifouling applications.<sup>[1]</sup>

## Chemical Identity & Structural Architecture Nomenclature and Classification

- Compound Name: **Sarasinoside C1**<sup>[1][2][3][4]</sup>

- Chemical Class: Triterpenoid Saponin (30-norlanostane glycoside)[1][5]
- Source Organism: Melophlus sarasinorum (Porifera, Demospongiae, Geodiidae)[1][5][6][7]

- Molecular Formula:

[1][4]

- Molecular Weight: ~1097.3 Da (Calculated),

1097.6000

(HRESIMS)[1]

## Structural Elucidation

The structure of **Sarasinoside C1** is defined by two distinct domains: a lipophilic aglycone core and a hydrophilic oligosaccharide chain.[1]

### A. The Aglycone Core (Aglycone 1)

The aglycone is a 30-norlanostane derivative, specifically 3

-hydroxy-30-norlanosta-8(9)-en-23-one.[1]

- Skeleton: Tetracyclic triterpene (steroid-like).[1]
- Key Features:
  - C-3:  
-hydroxyl group (glycosidation site).[1]
  - C-8(9): Endocyclic double bond.[1]
  - C-23: Ketone functionality (characteristic of sarasinoside aglycones).[1]
  - Side Chain: Cholestane-like side chain with oxidation at C-23.[1]

### B. The Oligosaccharide Moiety (Tetraose)

**Sarasinocide C1** possesses a branched tetraose chain attached to C-3 of the aglycone.[1] The sugar sequence is unique to the C-series sarasinocides.[1]

- Composition:
  - -D-Xylose (Inner, Aglycone-linked)[1]
  - -Acetyl-  
-D-glucosamine (GlcNAc)[1]
  - -Acetyl-  
-D-galactosamine (GalNAc)[1]
  - -D-Xylose (Terminal)[1]
- Connectivity: The inner xylose serves as the branching point:[1]
  - Position 2: Linked to GlcNAc, which is further substituted at C-6 by the terminal Xylose.[1]
  - Position 4: Linked to GalNAc.[1][2][8]

Chemical Notation:

[1][2]

## Structural Visualization

The following diagram illustrates the logical connectivity of the **Sarasinocide C1** molecule.

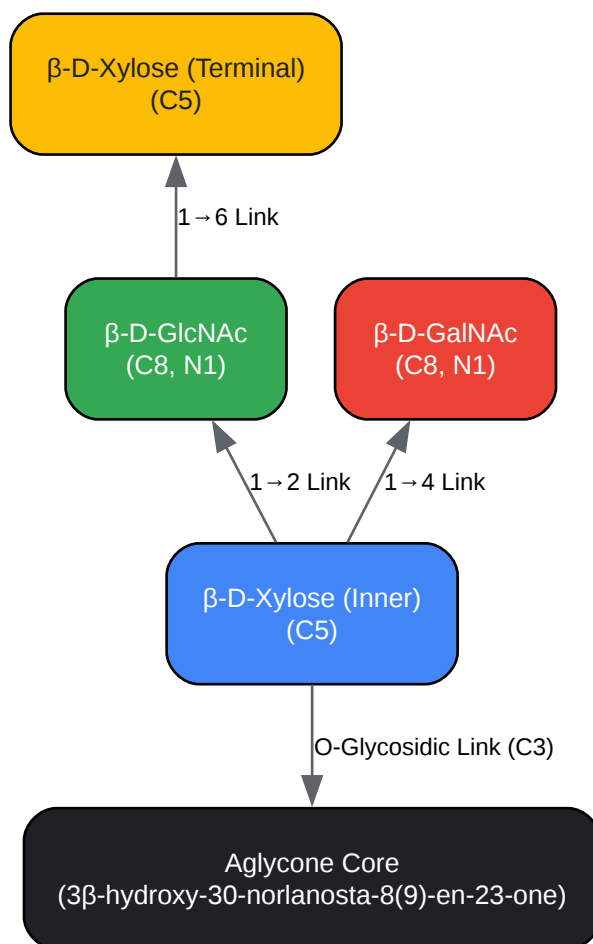

Figure 1: Structural Connectivity of Sarasinose C1 Glycoside Chain

[Click to download full resolution via product page](#)

[1]

## Physicochemical Properties & Spectral Characteristics

Accurate identification requires comparison against established spectral fingerprints.[1]

## General Properties

Property	Description
Physical State	Amorphous solid (yellowish or white powder)
Solubility	Soluble in MeOH, Pyridine, DMSO; sparingly soluble in water; insoluble in hexane.[1]
Stability	Susceptible to acid hydrolysis (cleaves glycosidic bonds).[1] Stable under neutral conditions.
Reactivity	Forms foam in aqueous solution (surfactant properties).[1]

## Key NMR Signals (Pyridine- )

Note: Chemical shifts (

) are approximate based on congener data.

- Aglycone Region:
  - H-3 ( ):  
~3.1-3.3 ppm (dd) – Diagnostic of 3 -substitution.[1]
  - Methyls: Five singlet methyls ( 0.7 – 1.2 ppm) characteristic of the norlanostane skeleton.[1]
  - Olefinic Protons: No vinylic protons for 8(9)-ene (tetrasubstituted).[1]
- Sugar Region (Anomeric Protons):
  - Four distinct doublet signals in the 4.3 – 5.5 ppm range.[1]

- NH Acetyl: Two singlet signals at  
~2.0-2.1 ppm (corresponding to GlcNAc and GalNAc).[1]

## Isolation and Purification Protocol

The following protocol is synthesized from standard marine natural product isolation workflows tailored for polar saponins like Sarasinoides.

### Workflow Logic

The extraction exploits the amphiphilic nature of saponins.[1]

- Extraction: Polar solvent (MeOH/EtOH) to release glycosides from the sponge matrix.[1]
- Partitioning:
  - Butanol (n-BuOH) is used to selectively concentrate saponins from salts (aqueous phase) and lipids (hexane phase).[1]
- Purification: Reversed-phase chromatography separates congeners based on the sugar chain length and aglycone polarity.[1]

### Step-by-Step Protocol

- Tissue Preparation:
  - Lyophilize fresh *Melophlus sarasinorum* sponge tissue.[1]
  - Grind to a fine powder.[1]
- Crude Extraction:
  - Extract powder with MeOH (3 x 1L) at room temperature.
  - Combine extracts and concentrate under reduced pressure to yield a crude gum.[1]
- Liquid-Liquid Partitioning (Desalting & Delipidation):

- Suspend crude gum in H<sub>2</sub>O (500 mL).
- Partition against
  - Hexane (500 mL) to remove lipids/sterols.[1] Discard hexane layer.[1]
- Partition aqueous layer against
  - BuOH (500 mL).
- Collect the
  - BuOH layer (contains Sarasinoids).[1] Evaporate to dryness.
- Flash Chromatography (Enrichment):
  - Stationary Phase: Amberlite XAD-2 or Diaion HP-20.[1]
  - Elution Gradient: H<sub>2</sub>O
    - 50% MeOH
    - 100% MeOH.[1]
  - **Sarasinoid C1** typically elutes in the 80-100% MeOH fractions.[1]
- Final Purification (HPLC):
  - Column: C18 Reversed-Phase (e.g., Phenomenex Luna, 5µm, 250 x 10 mm).[1]
  - Mobile Phase: Isocratic 65% MeOH / 35% H<sub>2</sub>O or Gradient 60-80% MeOH.[1]
  - Detection: Refractive Index (RI) or ELSD (due to weak UV chromophores).[1]
  - Target: Collect peak corresponding to  
1097.[1][4]

## Isolation Workflow Diagram

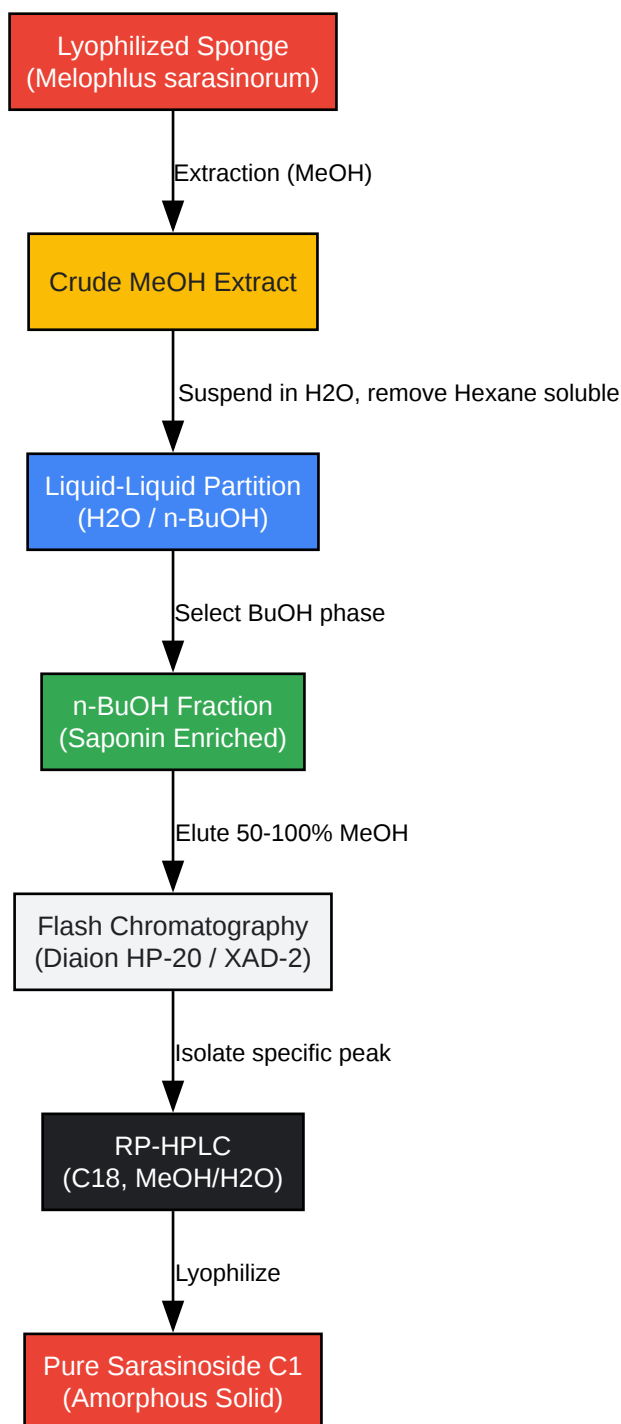

Figure 2: Isolation Protocol for Sarasinose C1

[Click to download full resolution via product page](#)

## Biological Profile & Mechanism of Action[1][6][9]

**Sarasinocide C1** exhibits a "defense" profile typical of marine saponins, showing potent cytotoxicity and ichthyotoxicity.[1]

## Cytotoxicity

**Sarasinocide C1** has demonstrated moderate to potent cytotoxicity against various cancer cell lines.[1]

- Mechanism: Membrane permeabilization (detergent effect) and potential interaction with specific membrane receptors.[1]
- Activity Data (Representative):
  - HeLa Cells: IC values typically in the low micromolar range ( ).[1]
  - K562 (Leukemia): Effective inhibition of proliferation.[1]

## Antifouling Activity

Recent studies highlight the ecological role of sarasinocides as antifoulants.[1]

- Target: Inhibition of larval settlement (e.g., *Mytilus galloprovincialis*, *Balanus amphitrite*).[1]
- Ecological Advantage: Unlike heavy metal antifoulants, **Sarasinocide C1** is biodegradable and exhibits a favorable toxicity profile (LC /EC ratio > 15), indicating a non-toxic mechanism of repulsion rather than killing.[1]

## Structure-Activity Relationship (SAR)

- Sugar Chain Importance: The branched tetrasaccharide is critical for solubility and interaction with biological membranes.[1] Analogues with shorter chains (e.g., bis-glycosides) often show reduced potency.[1]

- Aglycone Oxidation: The C-23 ketone and the 8(9) double bond are conserved features in the most active congeners.[1]

## References

- Additional Sarasinosides from the Marine Sponge *Melophlus sarasinorum* Collected from the Bismarck Sea. *Journal of Natural Products*, 2023.[1] Citation for: Isolation, structure elucidation, and tetraose moiety confirmation.[1]
- Triterpene and Steroid Glycosides from Marine Sponges (Porifera, Demospongiae): Structures, Taxonomical Distribution, Biological Activities. *Marine Drugs*, 2023.[1] Citation for: Cytotoxicity data, ichthyotoxicity, and structural classification.[1]
- Harnessing the metabolites from the marine sponge *Melophlus sarasinorum* for the discovery of eco-friendly antifoulants. *Biodiversitas*, 2025.[1][9] Citation for: Antifouling properties and ecological toxicity parameters.[1]
- Sarasinoside Chemical Diversity Revealed by Mass Spectrometry. *Journal of Natural Products* (via ResearchGate), 2019.[1] Citation for: Mass spectrometry fragmentation and molecular networking of sarasinosides.
- Structures of sarasinosides A1, B1, and C1; new norlanostane-triterpenoid oligoglycosides. *Chemical & Pharmaceutical Bulletin*, 1987.[1][3] Citation for: Original discovery and nomenclature.

### Need Custom Synthesis?

BenchChem offers custom synthesis for rare earth carbides and specific isotopic labeling.

Email: [info@benchchem.com](mailto:info@benchchem.com) or [Request Quote Online](#).

## Sources

- 1. [Sarasinose J | C62H102N2O27 | CID 11658230 - PubChem \[pubchem.ncbi.nlm.nih.gov\]](#)
- 2. [Additional Sarasinosides from the Marine Sponge \*Melophlus sarasinorum\* Collected from the Bismarck Sea - PubMed \[pubmed.ncbi.nlm.nih.gov\]](#)

- [3. Structures of sarasinosides A1, B1, and C1; new norlanostane-triterpenoid oligoglycosides from the Palauan marine sponge Asteropus sarasinusum - PubMed](#) [pubmed.ncbi.nlm.nih.gov]
- [4. pubs.acs.org](#) [pubs.acs.org]
- [5. researchgate.net](#) [researchgate.net]
- [6. researchgate.net](#) [researchgate.net]
- [7. vliz.be](#) [vliz.be]
- [8. researchgate.net](#) [researchgate.net]
- [9. researchgate.net](#) [researchgate.net]
- To cite this document: BenchChem. [Technical Monograph: Sarasinamide C1 – Chemical Architecture, Isolation, and Bioactivity Profile]. BenchChem, [2026]. [Online PDF]. Available at: [<https://www.benchchem.com/product/b1680772/docs#technical-monograph-sarasinamide-c1-chemical-architecture-isolation-and-bioactivity-profile>]

---

#### Disclaimer & Data Validity:

The information provided in this document is for Research Use Only (RUO) and is strictly not intended for diagnostic or therapeutic procedures. While BenchChem strives to provide accurate protocols, we make no warranties, express or implied, regarding the fitness of this product for every specific experimental setup.

**Technical Support:** The protocols provided are for reference purposes. Unsure if this reagent suits your experiment?

**Need Industrial/Bulk Grade?** [Request Custom Synthesis Quote](#)

## BenchChem

Our mission is to be the trusted global source of essential and advanced chemicals, empowering scientists and researchers to drive progress in science and industry.

#### Contact

Address: 3281 E Guasti Rd  
Ontario, CA 91761, United States  
Phone: (601) 213-4426  
Email: [info@benchchem.com](mailto:info@benchchem.com)

Contact our Ph.D. Support Team for a compatibility check