

Ro 90-7501 batch-to-batch variability

Author: BenchChem Technical Support Team. **Date:** December 2025

Compound of Interest

Compound Name: Ro 90-7501

Cat. No.: B1680707

[Get Quote](#)

Technical Support Center: Ro 90-7501

This technical support center provides troubleshooting guides and frequently asked questions (FAQs) to assist researchers, scientists, and drug development professionals in utilizing **Ro 90-7501**. The information is designed to address specific issues that may arise during experimentation, with a focus on mitigating factors that can be perceived as batch-to-batch variability.

Frequently Asked Questions (FAQs)

Q1: What is the primary mechanism of action for **Ro 90-7501**?

A1: **Ro 90-7501** is a multi-target compound. Its most cited primary function is as an inhibitor of amyloid β 42 (A β 42) fibril assembly, where it has been shown to reduce A β 42-induced cytotoxicity with an EC50 of 2 μ M.^{[1][2]} Additionally, it exhibits several other biological activities:

- Inhibition of ATM phosphorylation, which is involved in DNA damage repair.^{[2][3][4]}
- Selective enhancement of toll-like receptor 3 (TLR3) and RIG-I-like receptor (RLR) ligand-induced IFN- β gene expression and antiviral response.^{[1][2]}
- Inhibition of protein phosphatase 5 (PP5) in a TPR-dependent manner.^{[1][2]}
- Significant radiosensitizing effects on cervical cancer cells.^{[1][2][3]}

Q2: How should I store and handle **Ro 90-7501** to ensure its stability?

A2: Proper storage and handling are critical for maintaining the activity of **Ro 90-7501** and avoiding experimental variability. Solutions of **Ro 90-7501** are known to be unstable and it is highly recommended to prepare them fresh for each experiment.[1] For short-term storage of stock solutions, some suppliers suggest that it can be stored at -80°C for up to two years.[2] The powdered form is more stable and should be stored at -20°C.[1][5][6]

Q3: What is the recommended solvent for dissolving **Ro 90-7501**?

A3: The recommended solvent for **Ro 90-7501** is Dimethyl sulfoxide (DMSO).[6][7] Some datasheets indicate that sonication may be necessary to achieve complete dissolution.[7] Incomplete dissolution can be a significant source of variability in experimental results.

Q4: Is there known batch-to-batch variability for **Ro 90-7501**?

A4: While manufacturers typically ensure high purity ($\geq 98\%$)[8], slight batch-to-batch variations can occur, which may affect properties like solubility.[9] However, many issues that appear to be batch-related may actually stem from improper handling, storage of solutions, or variations in the experimental setup itself.[10][11]

Troubleshooting Guide

| Issue | Possible Cause | Recommended Action |
|---|--|--|
| Inconsistent or lower-than-expected activity between experiments. | <ol style="list-style-type: none">1. Degradation of Ro 90-7501 in solution.2. Incomplete dissolution of the compound.3. Variations in experimental conditions (e.g., cell density, incubation time). | <ol style="list-style-type: none">1. Always prepare fresh solutions of Ro 90-7501 for each experiment.[1]2. Ensure complete dissolution in DMSO, using sonication if necessary. Visually inspect the solution for any precipitate.[7]3. Standardize all experimental parameters and include positive and negative controls in every assay. |
| Precipitate forms when adding Ro 90-7501 solution to aqueous media. | <ol style="list-style-type: none">1. Poor solubility of the compound in aqueous buffers. | <ol style="list-style-type: none">1. Ensure the final concentration of DMSO in the culture medium is as low as possible while maintaining the solubility of Ro 90-7501. Perform serial dilutions to minimize the amount of DMSO added to the aqueous solution. |
| High background signal or off-target effects observed. | <ol style="list-style-type: none">1. The compound has multiple known biological targets.[1][2] | <ol style="list-style-type: none">1. Be aware of the different signaling pathways affected by Ro 90-7501 (e.g., ATM, PP5).[3][12] Design experiments with appropriate controls to isolate the effect of interest. |
| Variability in A β 42 aggregation assays. | <ol style="list-style-type: none">1. Inherent quality differences in synthetic Aβ42 peptide batches.[10] | <ol style="list-style-type: none">1. If possible, use a single, well-characterized batch of Aβ42 for a series of experiments. Characterize the aggregation kinetics of each new batch of Aβ42 before use with inhibitors. |

Quantitative Data Summary

| Parameter | Value | Reference |
|--|--------------|-----------|
| EC50 for A β 42-induced cytotoxicity reduction | 2 μ M | [1][2] |
| Purity | \geq 98% | [8] |
| Molecular Weight | 340.39 g/mol | [8] |
| Molecular Formula | C20H16N6 | [8] |

Storage Recommendations

| Form | Storage Temperature | Duration | Reference |
|-------------------|---------------------|---------------|-----------|
| Powder | -20°C | Up to 3 years | [1][7] |
| In Solvent (DMSO) | -80°C | Up to 2 years | [2][7] |
| In Solvent (DMSO) | -20°C | Up to 1 year | [2][7] |

Experimental Protocols

General Protocol for Cell-Based Assays

This protocol provides a general framework. Specific parameters such as cell type, seeding density, and treatment duration should be optimized for your particular experimental system.

- Preparation of **Ro 90-7501** Stock Solution:
 - On the day of the experiment, allow the powdered **Ro 90-7501** to equilibrate to room temperature.
 - Prepare a high-concentration stock solution (e.g., 10 mM) by dissolving the compound in high-quality, anhydrous DMSO.
 - If necessary, use a sonicator to ensure complete dissolution. Visually confirm that no particulates are present.

- Cell Seeding:
 - Plate cells in appropriate culture vessels at a predetermined density. Allow cells to adhere and enter a logarithmic growth phase (typically 24 hours).
- Treatment with **Ro 90-7501**:
 - Prepare serial dilutions of the **Ro 90-7501** stock solution in cell culture medium to achieve the desired final concentrations.
 - Ensure the final DMSO concentration is consistent across all treatment groups, including the vehicle control, and is non-toxic to the cells.
 - Remove the old medium from the cells and add the medium containing **Ro 90-7501** or vehicle control.
- Incubation and Analysis:
 - Incubate the cells for the desired period (e.g., 24, 48, or 72 hours).
 - Following incubation, perform the desired downstream analysis, such as a cell viability assay (e.g., MTT, CellTiter-Glo), western blotting for target proteins, or flow cytometry.

Visualizations

Signaling Pathway of Ro 90-7501 in Radiosensitization

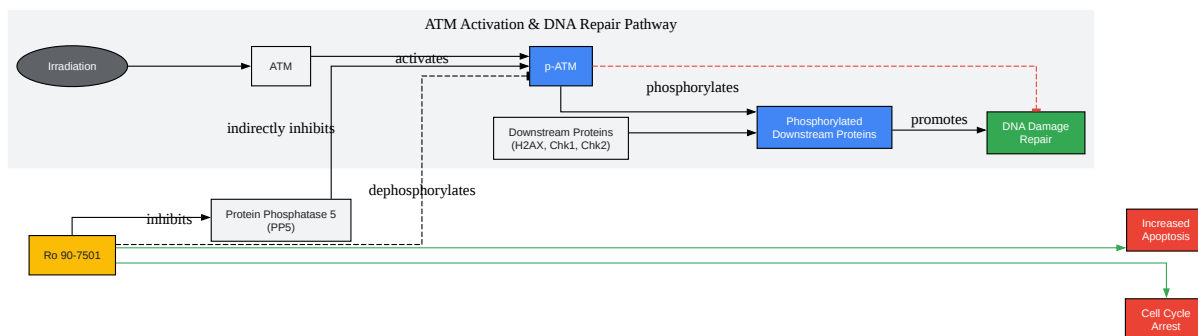

[Click to download full resolution via product page](#)

Caption: **Ro 90-7501**'s role in inhibiting the ATM DNA damage response pathway.

Troubleshooting Workflow for Inconsistent Results

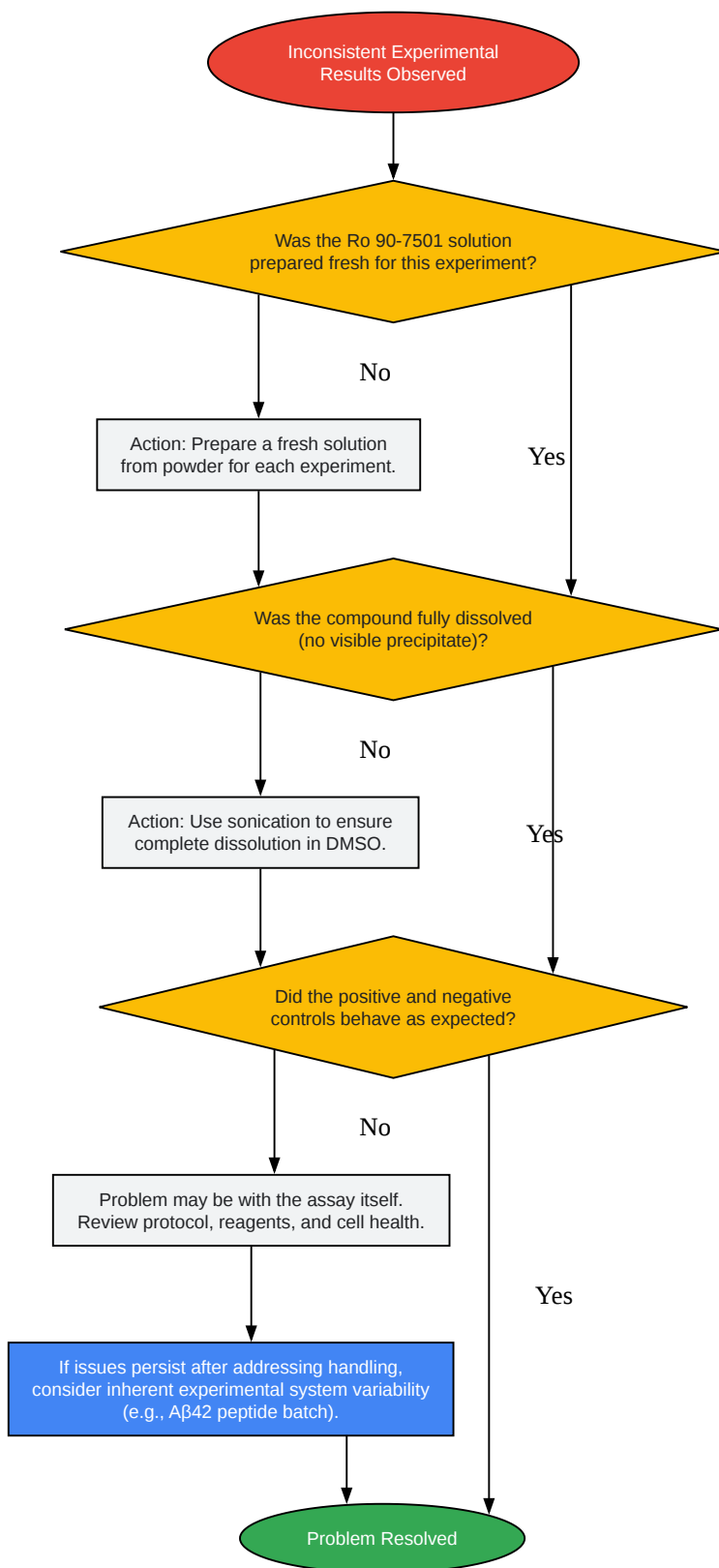

[Click to download full resolution via product page](#)

Caption: A logical workflow for troubleshooting inconsistent **Ro 90-7501** results.

Need Custom Synthesis?

BenchChem offers custom synthesis for rare earth carbides and specific isotopic labeling.

Email: info@benchchem.com or [Request Quote Online](#).

References

- 1. selleckchem.com [selleckchem.com]
- 2. medchemexpress.com [medchemexpress.com]
- 3. Ro 90-7501 Is a Novel Radiosensitizer for Cervical Cancer Cells that Inhibits ATM Phosphorylation | Anticancer Research [ar.iijournals.org]
- 4. Ro 90-7501 Is a Novel Radiosensitizer for Cervical Cancer Cells that Inhibits ATM Phosphorylation - PubMed [pubmed.ncbi.nlm.nih.gov]
- 5. Ro 90-7501|293762-45-5|MSDS [dcchemicals.com]
- 6. Ro 90-7501 | A β 42 inhibitor | Probechem Biochemicals [probechem.com]
- 7. file.medchemexpress.com [file.medchemexpress.com]
- 8. scbt.com [scbt.com]
- 9. selleckchem.com [selleckchem.com]
- 10. refubium.fu-berlin.de [refubium.fu-berlin.de]
- 11. researchgate.net [researchgate.net]
- 12. ar.iijournals.org [ar.iijournals.org]
- To cite this document: BenchChem. [Ro 90-7501 batch-to-batch variability]. BenchChem, [2025]. [Online PDF]. Available at: [<https://www.benchchem.com/product/b1680707#ro-90-7501-batch-to-batch-variability>]

Disclaimer & Data Validity:

The information provided in this document is for Research Use Only (RUO) and is strictly not intended for diagnostic or therapeutic procedures. While BenchChem strives to provide accurate protocols, we make no warranties, express or implied, regarding the fitness of this product for every specific experimental setup.

Technical Support: The protocols provided are for reference purposes. Unsure if this reagent suits your experiment? [[Contact our Ph.D. Support Team for a compatibility check](#)]

Need Industrial/Bulk Grade? [Request Custom Synthesis Quote](#)

BenchChem

Our mission is to be the trusted global source of essential and advanced chemicals, empowering scientists and researchers to drive progress in science and industry.

Contact

Address: 3281 E Guasti Rd

Ontario, CA 91761, United States

Phone: (601) 213-4426

Email: info@benchchem.com