

Optimizing RU26988 treatment duration for maximal response.

Author: BenchChem Technical Support Team. **Date:** April 2026

Compound of Interest

Compound Name: RU26988
CAS No.: 74915-58-5
Cat. No.: B1680169

[Get Quote](#)

Technical Support Center: RU26988 Treatment

Welcome to the technical support center for **RU26988**. This resource provides troubleshooting guides and frequently asked questions (FAQs) to help researchers, scientists, and drug development professionals optimize their experiments for maximal response when using **RU26988**.

Frequently Asked Questions (FAQs)

Q1: What is **RU26988** and what is its primary mechanism of action?

A1: **RU26988** is a highly selective glucocorticoid receptor (GR) antagonist.^{[1][2]} Its primary function is to block the binding of glucocorticoids, such as cortisol, to the GR.^{[1][2]} The GR, also known as NR3C1, is a transcription factor that, upon activation by a ligand, translocates from the cytoplasm to the nucleus to regulate gene expression.^{[3][4]}

Q2: Why is **RU26988** used in studying the mineralocorticoid receptor (MR)?

A2: The mineralocorticoid receptor (MR) has a high affinity for both mineralocorticoids (like aldosterone) and glucocorticoids.[5] In many cell types, the concentration of glucocorticoids is significantly higher than that of mineralocorticoids. To specifically study the effects of MR activation by mineralocorticoids without the confounding effects of glucocorticoid binding, **RU26988** is used to selectively block the GR.[1][2]

Q3: How does the mineralocorticoid receptor signaling pathway work?

A3: In its inactive state, the mineralocorticoid receptor resides in the cytoplasm complexed with heat shock proteins. Upon binding to its ligand (e.g., aldosterone), the receptor undergoes a conformational change, dissociates from the heat shock proteins, and translocates to the nucleus. Inside the nucleus, it forms homodimers and binds to hormone response elements (HREs) on the DNA, leading to the transcription of target genes.[5]

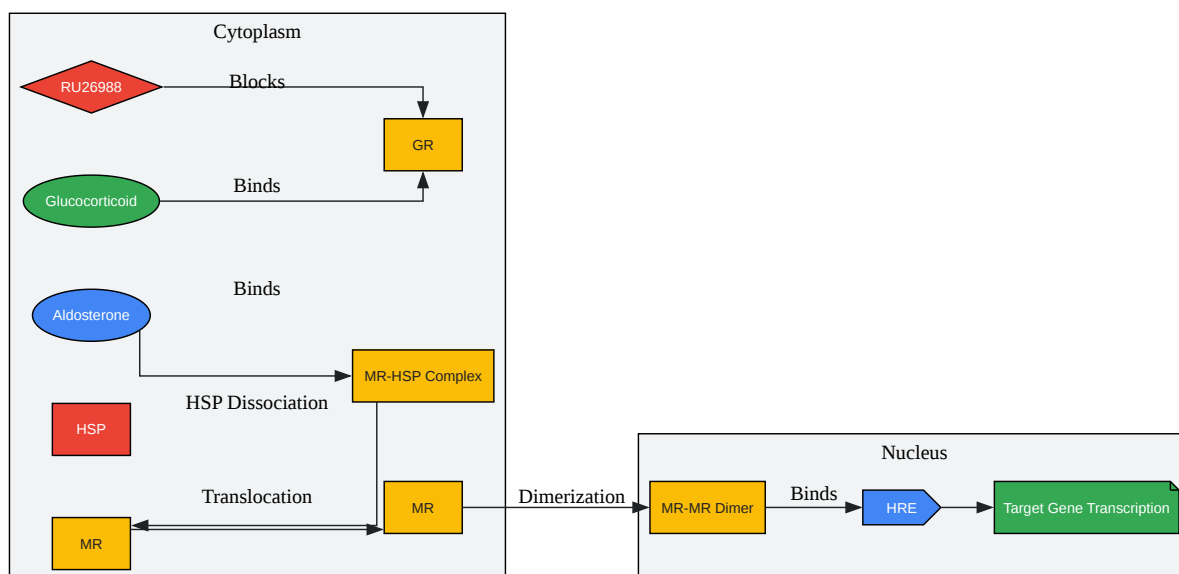

[Click to download full resolution via product page](#)

Mineralocorticoid Receptor (MR) Signaling Pathway.

Troubleshooting Guide

Issue 1: High variability in experimental results.

- Possible Cause: Inconsistent cell culture conditions.
 - Solution: Standardize cell passage number, seeding density, and confluence at the time of treatment. Use a single, quality-tested batch of serum for a set of experiments to minimize variability.
- Possible Cause: Presence of endogenous glucocorticoids in serum.
 - Solution: Use charcoal-stripped serum to remove endogenous steroids, which can otherwise activate the GR and interfere with your experiment.
- Possible Cause: Instability of **RU26988** in culture medium.
 - Solution: Prepare fresh dilutions of **RU26988** from a stock solution for each experiment. While specific stability data for **RU26988** in culture media is not readily available, it is a general good practice for small molecules.

Issue 2: No observable effect after **RU26988** treatment.

- Possible Cause: Low or absent glucocorticoid receptor expression in the cell line.
 - Solution: Verify GR expression in your cell line using methods like qPCR or Western blot. Compare the expression level to a known GR-positive cell line.
- Possible Cause: Suboptimal concentration of **RU26988**.
 - Solution: Perform a dose-response experiment to determine the optimal concentration of **RU26988** for your specific cell line and experimental conditions.
- Possible Cause: Insufficient treatment duration.

- Solution: The optimal treatment duration can vary. A time-course experiment is recommended to determine the point of maximal response. See the experimental protocol below for guidance.

Issue 3: Unexpected or off-target effects.

- Possible Cause: **RU26988** interacting with other cellular pathways.
 - Solution: While **RU26988** is highly selective for the GR, off-target effects are always a possibility, especially at high concentrations. Reduce the concentration of **RU26988** and ensure that the observed effects are consistent with GR antagonism.

Experimental Protocols

Protocol 1: Optimizing **RU26988** Treatment Duration (Time-Course Experiment)

This protocol provides a framework for determining the optimal treatment duration of **RU26988** for your specific experimental endpoint.

- Cell Seeding: Seed your cells in the appropriate culture vessels (e.g., 6-well plates, 96-well plates) at a density that will ensure they are in the logarithmic growth phase and at a consistent confluence at the time of treatment.
- Pre-treatment (if applicable): If your experiment involves stimulating a pathway that **RU26988** is intended to block, you may need to pre-incubate with **RU26988** before adding the stimulus.
- Treatment: Add the predetermined optimal concentration of **RU26988** to your cells. Include a vehicle-only control.
- Time Points: Harvest or analyze the cells at various time points (e.g., 1, 2, 4, 8, 12, 24, 48 hours). The selection of time points should be based on the expected kinetics of the biological response you are measuring.
- Endpoint Analysis: Analyze your endpoint of interest. This could be gene expression (qPCR), protein levels (Western blot), cell viability (MTT assay), or another relevant metric.

- Data Analysis: Plot the response against time to determine the duration at which the maximal effect of **RU26988** is observed.

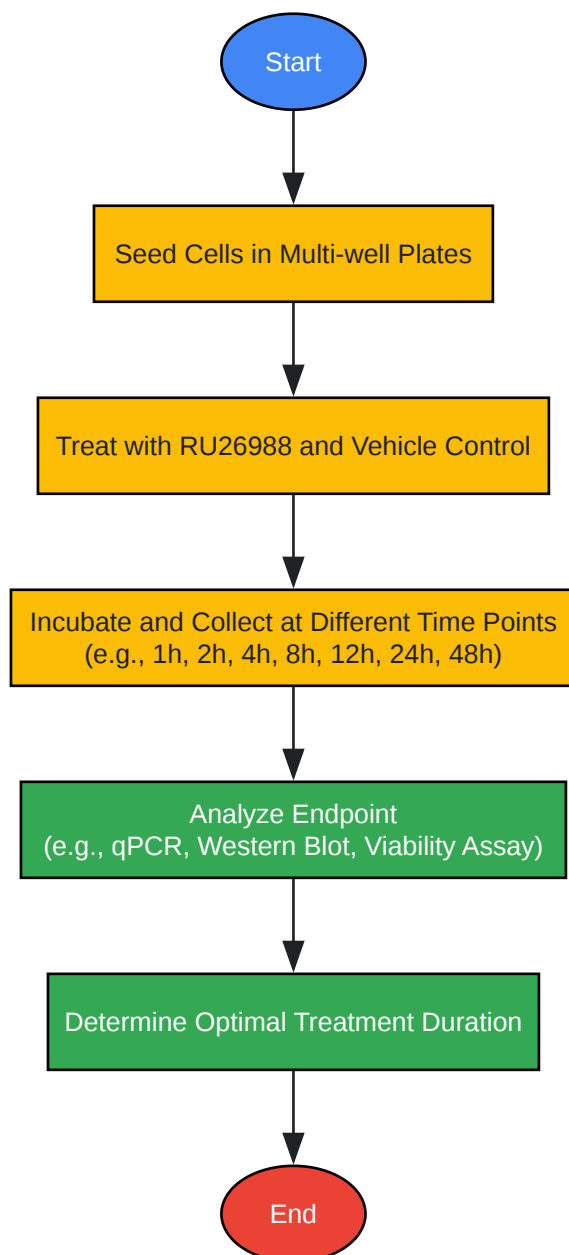

[Click to download full resolution via product page](#)

Workflow for Optimizing Treatment Duration.

Data Presentation: Time-Course Experiment

Time Point (hours)	Vehicle Control (Response)	RU26988 (Response)	% Inhibition/Effect
1			
2			
4			
8			
12			
24			
48			

This table is a template for recording your experimental data.

Need Custom Synthesis?

BenchChem offers custom synthesis for rare earth carbides and specific isotopic labeling.

Email: info@benchchem.com or [Request Quote Online](#).

References

- 1. [researchgate.net](https://www.researchgate.net) [[researchgate.net](https://www.researchgate.net)]
- 2. Aldosterone and Mineralocorticoid Receptor System in Cardiovascular Physiology and Pathophysiology - PMC [[pmc.ncbi.nlm.nih.gov](https://pubmed.ncbi.nlm.nih.gov/123456789/)]
- 3. Glucocorticoid receptor antagonism promotes apoptosis in solid tumor cells - PMC [[pmc.ncbi.nlm.nih.gov](https://pubmed.ncbi.nlm.nih.gov/123456789/)]
- 4. Vitamins in cell culture media: Stability and stabilization strategies - PubMed [[pubmed.ncbi.nlm.nih.gov](https://pubmed.ncbi.nlm.nih.gov/123456789/)]
- 5. Mineralocorticoid receptor - Wikipedia [[en.wikipedia.org](https://en.wikipedia.org/wiki/Mineralocorticoid_receptor)]
- To cite this document: BenchChem. [Optimizing RU26988 treatment duration for maximal response.]. BenchChem, [2026]. [Online PDF]. Available at: [<https://www.benchchem.com/product/b1680169/docs#optimizing-ru26988-treatment-duration-for-maximal-response>]

Disclaimer & Data Validity:

The information provided in this document is for Research Use Only (RUO) and is strictly not intended for diagnostic or therapeutic procedures. While BenchChem strives to provide accurate protocols, we make no warranties, express or implied, regarding the fitness of this product for every specific experimental setup.

Technical Support: The protocols provided are for reference purposes. Unsure if this reagent suits your experiment?

Need Industrial/Bulk Grade? [Request Custom Synthesis Quote](#)

BenchChem

Our mission is to be the trusted global source of essential and advanced chemicals, empowering scientists and researchers to drive progress in science and industry.

Contact

Address: 3281 E Guasti Rd
Ontario, CA 91761, United States
Phone: (601) 213-4426
Email: info@benchchem.com

[Contact our Ph.D. Support Team for a compatibility check](#)