

Independent Verification of S 18986's Mechanism of Action: A Comparative Guide

Author: BenchChem Technical Support Team. **Date:** April 2026

Compound of Interest

Compound Name:	S 18986
CAS No.:	175340-20-2
Cat. No.:	B1680379

[Get Quote](#)

For Researchers, Scientists, and Drug Development Professionals

This guide provides an objective comparison of the positive allosteric modulator of AMPA receptors, **S 18986**, with other relevant alternative compounds. The information presented is based on available experimental data to assist in the independent verification of its mechanism of action.

Mechanism of Action of S 18986

S 18986 is a selective positive allosteric modulator of α -amino-3-hydroxy-5-methyl-4-isoxazolepropionic acid (AMPA) type glutamate receptors.[1][2] Unlike direct agonists, **S 18986** does not activate AMPA receptors on its own. Instead, it enhances the receptor's response to the endogenous ligand, glutamate. This modulation is achieved by slowing the deactivation and/or desensitization of the receptor, leading to an increased influx of calcium ions (Ca^{2+}) and a prolonged duration of excitatory postsynaptic potentials (EPSPs).[1] This potentiation of AMPA receptor activity is believed to underlie its observed cognitive-enhancing effects.[1][2][3]

The primary mechanism of action of **S 18986** involves its binding to an allosteric site on the AMPA receptor, which is distinct from the glutamate binding site. This binding stabilizes the receptor in a conformation that has a higher affinity for glutamate and a reduced rate of desensitization.[1] This leads to an enhancement of synaptic plasticity, including long-term potentiation (LTP), a cellular mechanism crucial for learning and memory.[1][2]

Furthermore, **S 18986** has been shown to increase the expression of brain-derived neurotrophic factor (BDNF) and to modulate the release of various neurotransmitters, including noradrenaline and acetylcholine in the hippocampus and frontal cortex.[1][4][5]

Comparative Data: S 18986 vs. Alternative AMPA Receptor Modulators

To independently verify the mechanism of action of **S 18986**, its performance can be compared against other well-characterized positive allosteric modulators of AMPA receptors. The following tables summarize key quantitative data from comparative studies.

Table 1: In Vitro Potency of Various AMPA Receptor Modulators

Compound	EC2x (µM)	Description
LY404187	0.3	A potent AMPA receptor potentiator.
CX614	1.1	An ampakine compound.
Cyclothiazide	1.7	A benzothiadiazide diuretic with AMPA modulating properties.
S 18986	25	The compound of interest.
IDRA-21	134	A benzothiadiazide derivative.
Aniracetam	>3000	A nootropic drug of the racetam class.
CX516	>3000	The first ampakine tested in humans.

EC₂x represents the concentration of the compound required to double the AMPA-evoked current. Data sourced from Bernard et al. (2010).[1]

Table 2: Effect on (S)-AMPA-Mediated BDNF mRNA Expression in Rat Primary Cortical Neuronal Cultures

Compound	Maximal Enhancement (fold increase)	EC ₅₀ (μM)
Cyclothiazide	40	18
S 18986	3-5	Not determined
IDRA-21	Inactive	Not applicable

Data reflects the potentiation of BDNF mRNA expression induced by 3 μM (S)-AMPA. Data sourced from Lockhart et al. (2007).

Experimental Protocols

Detailed methodologies are crucial for the independent verification of experimental findings. Below are protocols for key experiments cited in the literature on **S 18986**.

Electrophysiological Recording in *Xenopus laevis* Oocytes

Objective: To determine the potentiation of AMPA-evoked currents by **S 18986** and other modulators.

Methodology:

- **Oocyte Preparation:** *Xenopus laevis* oocytes are injected with rat cortex poly(A⁺) mRNA to express AMPA receptors.
- **Recording Setup:** A standard two-electrode voltage-clamp system is used to record inward currents at a holding potential of -60 mV.
- **Agonist Application:** (S)-AMPA is bath-applied for 30 seconds to evoke a baseline current.

- Modulator Application: The test compound (e.g., **S 18986**) is bath-applied at increasing concentrations for 45 seconds before, 30 seconds during, and 30 seconds after the application of (S)-AMPA.
- Data Analysis: The potentiation of the AMPA-evoked current is measured and the EC2x value is calculated.[1]

In Vivo Microdialysis for Neurotransmitter Release

Objective: To measure the effect of **S 18986** on the extracellular levels of neurotransmitters in specific brain regions of freely moving rats.

Methodology:

- Probe Implantation: A microdialysis probe is stereotaxically implanted into the target brain region (e.g., hippocampus or frontal cortex).
- Perfusion: The probe is perfused with an artificial cerebrospinal fluid (aCSF) at a constant flow rate (e.g., 1-2 $\mu\text{L}/\text{min}$).
- Sample Collection: Dialysate samples are collected at regular intervals (e.g., every 20 minutes) before and after the administration of **S 18986** (intraperitoneally or orally).
- Neurotransmitter Analysis: The concentration of neurotransmitters (e.g., acetylcholine, noradrenaline) in the dialysate is quantified using high-performance liquid chromatography (HPLC) coupled with electrochemical detection.
- Data Analysis: Changes in neurotransmitter levels from baseline are calculated and compared between treatment and vehicle groups.

Measurement of BDNF mRNA Expression in Primary Neuronal Cultures

Objective: To assess the effect of **S 18986** on the expression of brain-derived neurotrophic factor.

Methodology:

- Cell Culture: Primary cortical neuronal cultures are prepared from rat embryos.
- Treatment: Cultures are treated with (S)-AMPA in the presence or absence of **S 18986** or other modulators for a specified duration (e.g., 6 hours).
- RNA Extraction: Total RNA is extracted from the neuronal cultures.
- Quantitative PCR (qPCR): The levels of BDNF mRNA are quantified using real-time qPCR, with a housekeeping gene used for normalization.
- Data Analysis: The fold change in BDNF mRNA expression relative to control cultures is calculated.

Visualizations

The following diagrams illustrate the key pathways and experimental workflows discussed.

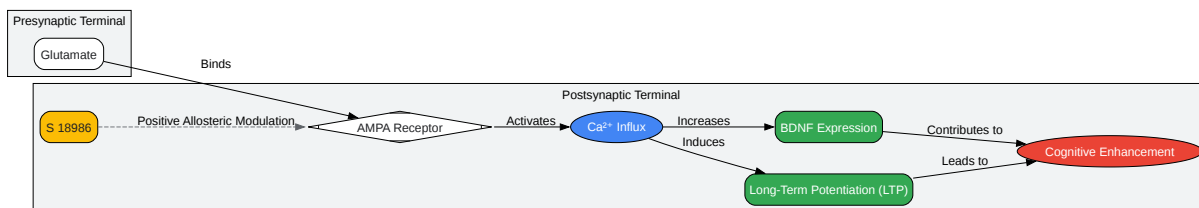

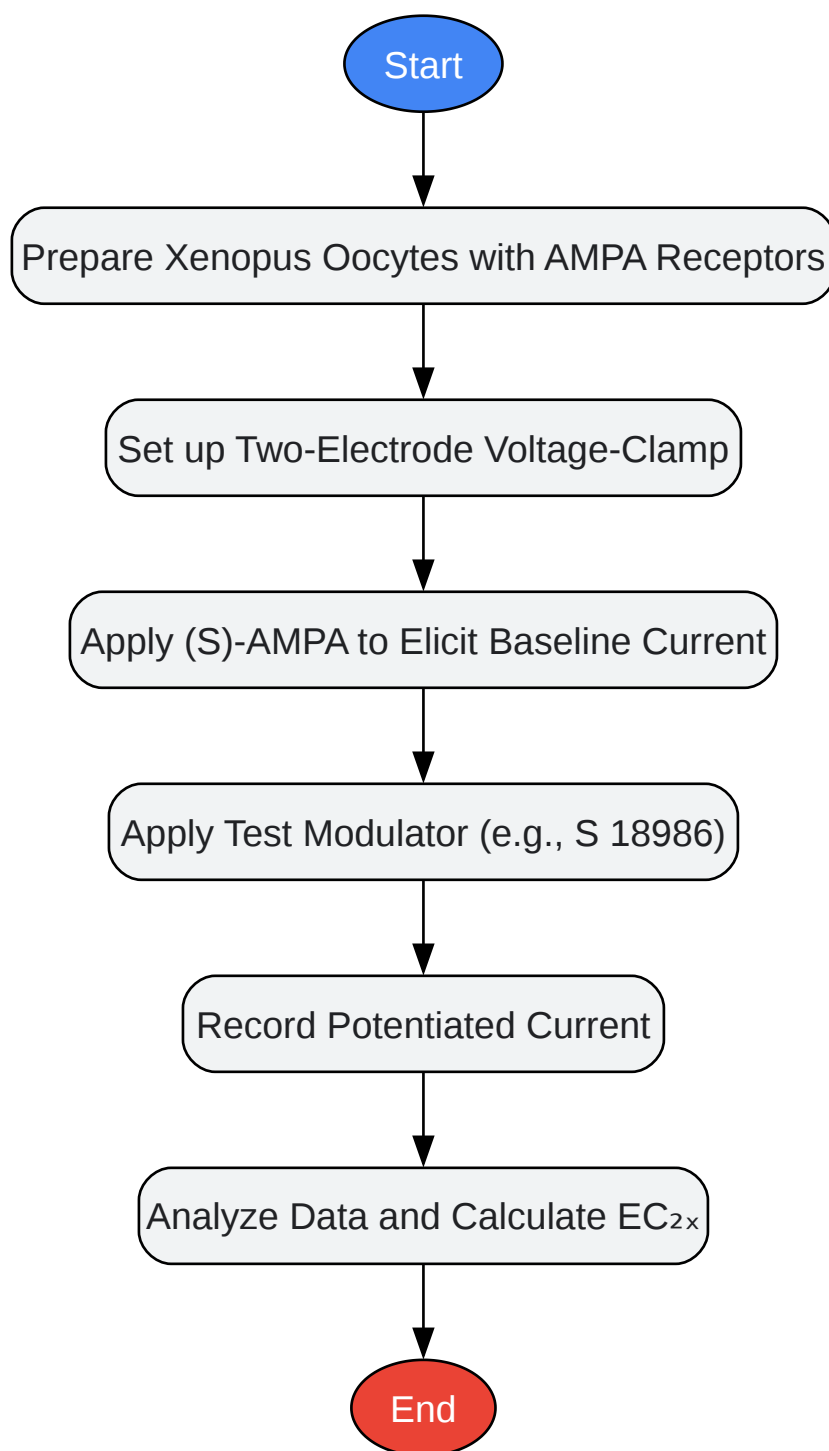

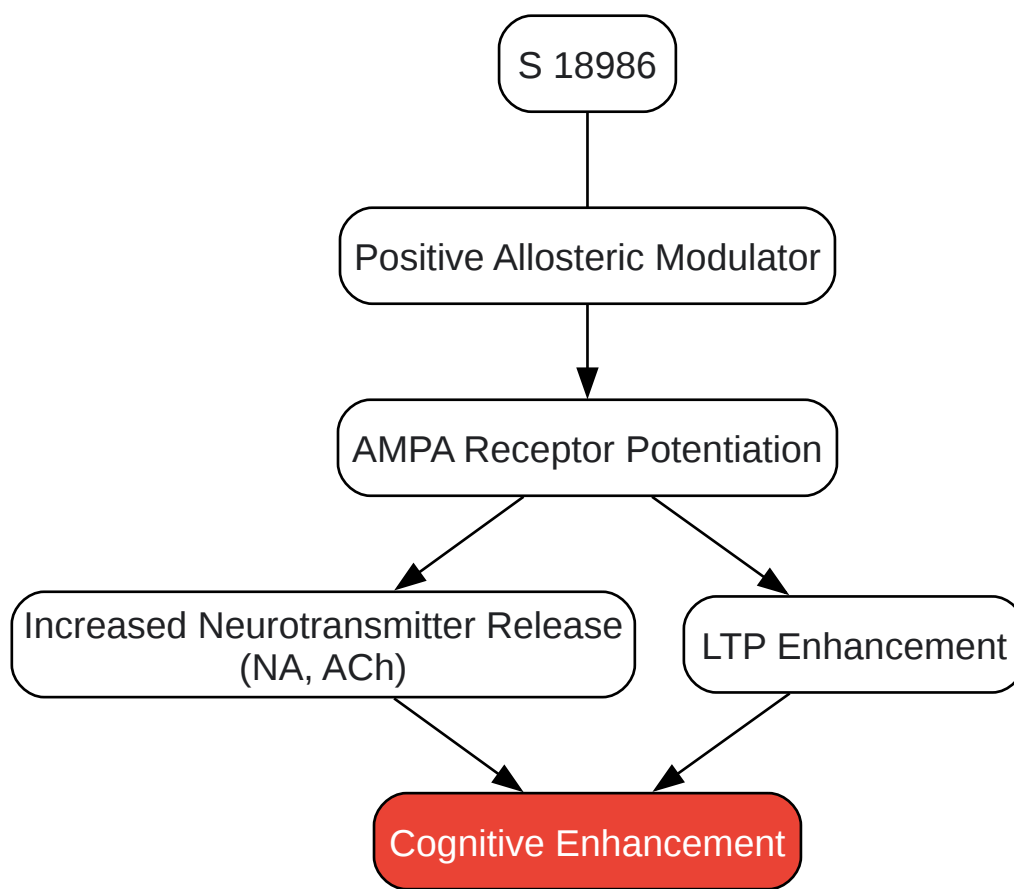

[Click to download full resolution via product page](#)

Need Custom Synthesis?

BenchChem offers custom synthesis for rare earth carbides and specific isotopic labeling.

Email: info@benchchem.com or [Request Quote Online](#).

References

- 1. DRUG FOCUS: S 18986: A Positive Allosteric Modulator of AMPA-Type Glutamate Receptors Pharmacological Profile of a Novel Cognitive Enhancer - PMC [[pmc.ncbi.nlm.nih.gov](https://pubmed.ncbi.nlm.nih.gov/31111111/)]
- 2. DRUG FOCUS: S 18986: A positive allosteric modulator of AMPA-type glutamate receptors pharmacological profile of a novel cognitive enhancer - PubMed [[pubmed.ncbi.nlm.nih.gov](https://pubmed.ncbi.nlm.nih.gov/31111111/)]

- [3. In Vivo Microdialysis Method to Collect Large Extracellular Proteins from Brain Interstitial Fluid with High-molecular Weight Cut-off Probes - PMC \[pmc.ncbi.nlm.nih.gov\]](#)
- [4. FUNCTIONAL INSIGHT INTO DEVELOPMENT OF POSITIVE ALLOSTERIC MODULATORS OF AMPA RECEPTORS - PMC \[pmc.ncbi.nlm.nih.gov\]](#)
- [5. researchgate.net \[researchgate.net\]](#)
- To cite this document: BenchChem. [Independent Verification of S 18986's Mechanism of Action: A Comparative Guide]. BenchChem, [2026]. [Online PDF]. Available at: [\[https://www.benchchem.com/product/b1680379/docs#independent-verification-of-s-18986-s-mechanism-of-action-a-comparative-guide\]](https://www.benchchem.com/product/b1680379/docs#independent-verification-of-s-18986-s-mechanism-of-action-a-comparative-guide)

Disclaimer & Data Validity:

The information provided in this document is for Research Use Only (RUO) and is strictly not intended for diagnostic or therapeutic procedures. While BenchChem strives to provide accurate protocols, we make no warranties, express or implied, regarding the fitness of this product for every specific experimental setup.

Technical Support: The protocols provided are for reference purposes. Unsure if this reagent suits your experiment?

Need Industrial/Bulk Grade? [Request Custom Synthesis Quote](#)

BenchChem

Our mission is to be the trusted global source of essential and advanced chemicals, empowering scientists and researchers to drive progress in science and industry.

Contact

Address: 3281 E Guasti Rd
Ontario, CA 91761, United States
Phone: (601) 213-4426
Email: info@benchchem.com

Contact our Ph.D. Support Team for a compatibility check