

An In-depth Technical Guide to the Function of NS5806

Author: BenchChem Technical Support Team. **Date:** April 2026

Compound of Interest

Compound Name: NS5806
CAS No.: 426834-69-7
Cat. No.: B1680101

[Get Quote](#)

For Researchers, Scientists, and Drug Development Professionals

Abstract

NS5806 is a potent and selective modulator of the voltage-gated potassium channel Kv4 complex, which is responsible for the transient outward potassium current (I_{to}). This current plays a critical role in the repolarization phase of the action potential in various excitable cells, including cardiomyocytes and neurons. The function of **NS5806** is uniquely dependent on the auxiliary subunit composition of the Kv4 channel complex, acting as an activator in the presence of KChIP2 and potentially as an inhibitor when the long isoform of DPP6 (DPP6-L) is also present. This guide provides a comprehensive overview of the molecular function of **NS5806**, summarizing key quantitative data, detailing experimental protocols, and visualizing its mechanism of action.

Core Function and Mechanism of Action

NS5806 directly modulates the gating properties of Kv4 channels, primarily Kv4.2 and Kv4.3, the pore-forming α -subunits that conduct the I_{to}. Its effects are contingent on the presence of cytosolic (KChIP) and transmembrane (DPP) auxiliary subunits.

1.1. Activation of Kv4/KChIP2 Complexes

In the presence of the potassium channel interacting protein 2 (KChIP2), **NS5806** functions as a channel activator. It increases the peak current amplitude and significantly slows the decay (inactivation) of Kv4.2 and Kv4.3 currents. Mechanistically, **NS5806** binds to a hydrophobic site on the C-terminus of KChIP3 (which shares high homology with KChIP2) in a calcium-dependent manner.[1] This binding enhances the affinity between KChIP3 and the N-terminus of the Kv4.3 channel, thereby stabilizing the open state and slowing the inactivation process.[1]

1.2. Inhibition of Kv4/KChIP2/DPP6-L Complexes

The functional outcome of **NS5806** modulation is altered by the presence of the dipeptidyl peptidase-like protein 6, specifically its long isoform (DPP6-L). When Kv4.2 or Kv4.3 channels are complexed with both KChIP2 and DPP6-L, **NS5806** can act as an inhibitor, suppressing the current and accelerating inactivation.[2] This differential effect is attributed to the varied expression of DPP6-L across different species and tissues, explaining the species-specific responses to **NS5806**. For instance, in canine cardiomyocytes where DPP6-L expression is low, **NS5806** potentiates Ito. Conversely, in mouse and human-induced pluripotent stem cell-derived cardiomyocytes (hiPSC-CMs) with dominant DPP6-L expression, **NS5806** inhibits Ito. [2][3]

1.3. Other Effects

NS5806 has been shown to inhibit Kv1.4-mediated currents independently of KChIP2. However, it does not significantly affect other potassium channels such as Kv7.1, Kv11.1 (hERG), or Kir2.[4]

Data Presentation

The following tables summarize the quantitative data on the effects of **NS5806** from various electrophysiological studies.

Table 1: Potency and Efficacy of **NS5806**

Parameter	Channel/Preparation	Value	Reference(s)
EC50 (Peak Current)	Kv4.3/KChIP2 in CHO-K1 cells	$5.3 \pm 1.5 \mu\text{M}$	[4]
EC50 (Inactivation τ)	Kv4.3/KChIP2/DPP6 in CHO-K1 cells	$25.4 \mu\text{M}$	[5]
Kd (NS5806 to KChIP3)	Ca ²⁺ -bound form	$2\text{-}5 \mu\text{M}$	[1]
Kd (KChIP3 to Kv4.3 N-terminus)	Apo-state	$70 \pm 3 \mu\text{M}$	[1]
Kd (KChIP3 to Kv4.3 N-terminus)	Ca ²⁺ -bound	$2.7 \pm 0.1 \mu\text{M}$	[1]
Kd (KChIP3 to Kv4.3 N-terminus)	With NS5806	$1.9 \pm 0.1 \mu\text{M}$	[1]

Table 2: Effects of **NS5806** on Current Density and Inactivation

Cell Type/Channel	NS5806 Concentration	Effect on Peak Current	Effect on Inactivation	Reference(s)
Kv4.3/KChIP2 in CHO-K1 cells	10 μ M	35% increase	Marked slowing (τ from 7.0 to 10.2 ms)	[6]
Kv4.3/KChIP2/DPP6 in CHO-K1 cells	10 μ M	65% increase	Slowed	[5]
Canine Epicardial Myocytes	10 μ M	80% increase	Slowed (Total charge increased to 227% of control)	[6]
Canine Midmyocardial Myocytes	10 μ M	82% increase	Slowed (Total charge increased to 192% of control)	[6]
Canine Endocardial Myocytes	10 μ M	16% increase	Slowed (Total charge increased to 83% of control)	[6]
Mouse Ventricular Myocytes	0.1-30 μ M	Concentration-dependent inhibition	Accelerated	[2]
hiPSC-CMs	0.1-30 μ M	Concentration-dependent inhibition	Accelerated	[2]
Rabbit Ventricular Myocytes	10-100 nM	Prolonged APD by 16.8%	[7][8]	

Experimental Protocols

The primary method for characterizing the function of **NS5806** is the whole-cell patch-clamp technique. This allows for the direct measurement of ion channel currents in various cell types, including isolated primary cardiomyocytes and heterologous expression systems like CHO-K1 and HEK293 cells.

3.1. Cell Preparation

- **Heterologous Expression:** CHO-K1 or HEK293 cells are transiently transfected with plasmids encoding the desired Kv4 α -subunit (e.g., Kv4.3) and auxiliary subunits (e.g., KChIP2, DPP6).
- **Cardiomyocyte Isolation:** Ventricular myocytes are enzymatically isolated from animal hearts (e.g., canine, mouse, rabbit) using standard protocols involving collagenase and protease digestion.

3.2. Electrophysiological Recordings

- **Configuration:** Whole-cell voltage-clamp configuration is established using a patch-clamp amplifier.
- **Solutions:**
 - **External Solution (aCSF):** Typically contains (in mM): 126 NaCl, 3 KCl, 2 MgSO₄, 2 CaCl₂, 1.25 NaH₂PO₄, 26.4 NaHCO₃, and 10 glucose, bubbled with 95% O₂ / 5% CO₂.[\[9\]](#)[\[10\]](#)
 - **Internal (Pipette) Solution:** A common composition includes (in mM): 115 K-Gluconate, 4 NaCl, 0.3 GTP-NaCl, 2 ATP-Mg, and 40 HEPES, with pH adjusted to 7.2 with KOH.[\[10\]](#)
- **Voltage Protocols:**
 - **Activation:** To measure the peak current, cells are held at a negative holding potential (e.g., -80 mV) and then depolarized to a range of test potentials (e.g., -40 to +60 mV) for a duration sufficient to elicit the peak current (e.g., 500 ms).
 - **Inactivation Kinetics:** The decay of the current during a sustained depolarizing pulse is fitted with one or two exponential functions to determine the time constants (τ) of inactivation.

- **Steady-State Inactivation:** A two-pulse protocol is used. A conditioning prepulse to various potentials is applied, followed by a test pulse to a fixed potential (e.g., +40 mV) to determine the fraction of available channels.

3.3. Data Analysis

Currents are recorded and analyzed using specialized software. Parameters such as peak current density (pA/pF), time constants of inactivation (τ), and the voltage-dependence of activation and inactivation are determined and compared before and after the application of **NS5806**.

Mandatory Visualization

4.1. Signaling Pathways and Experimental Workflows

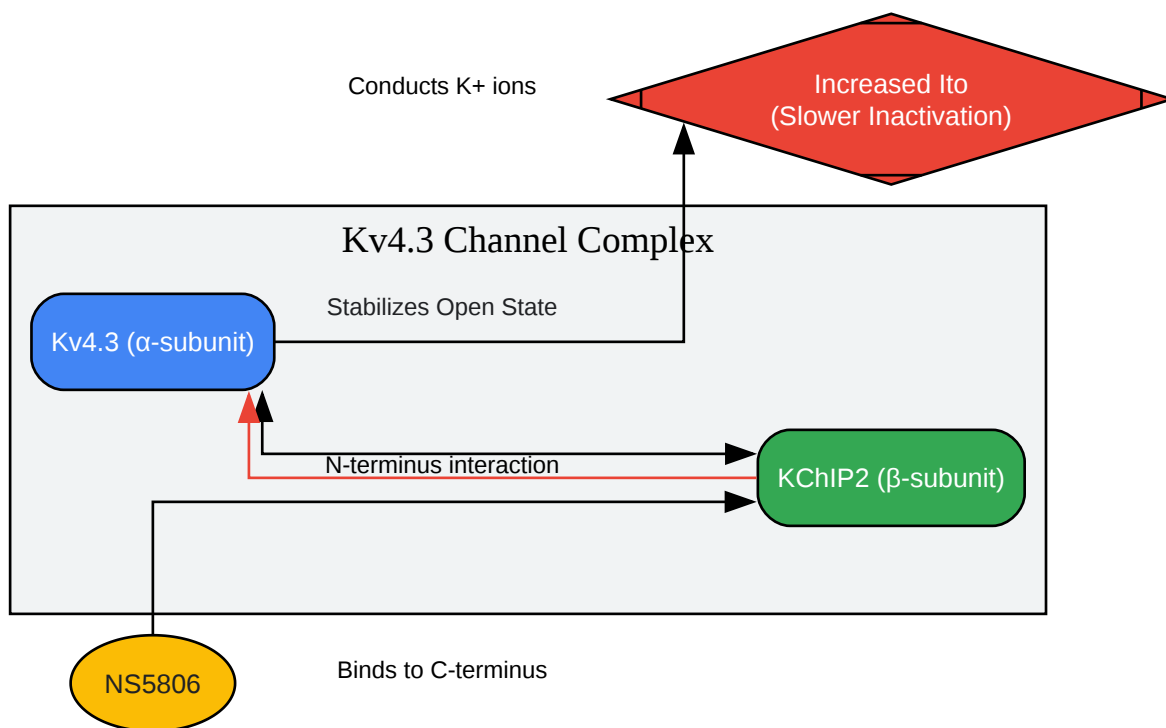

[Click to download full resolution via product page](#)

Caption: **NS5806** activation of the Kv4.3/KChIP2 channel complex.

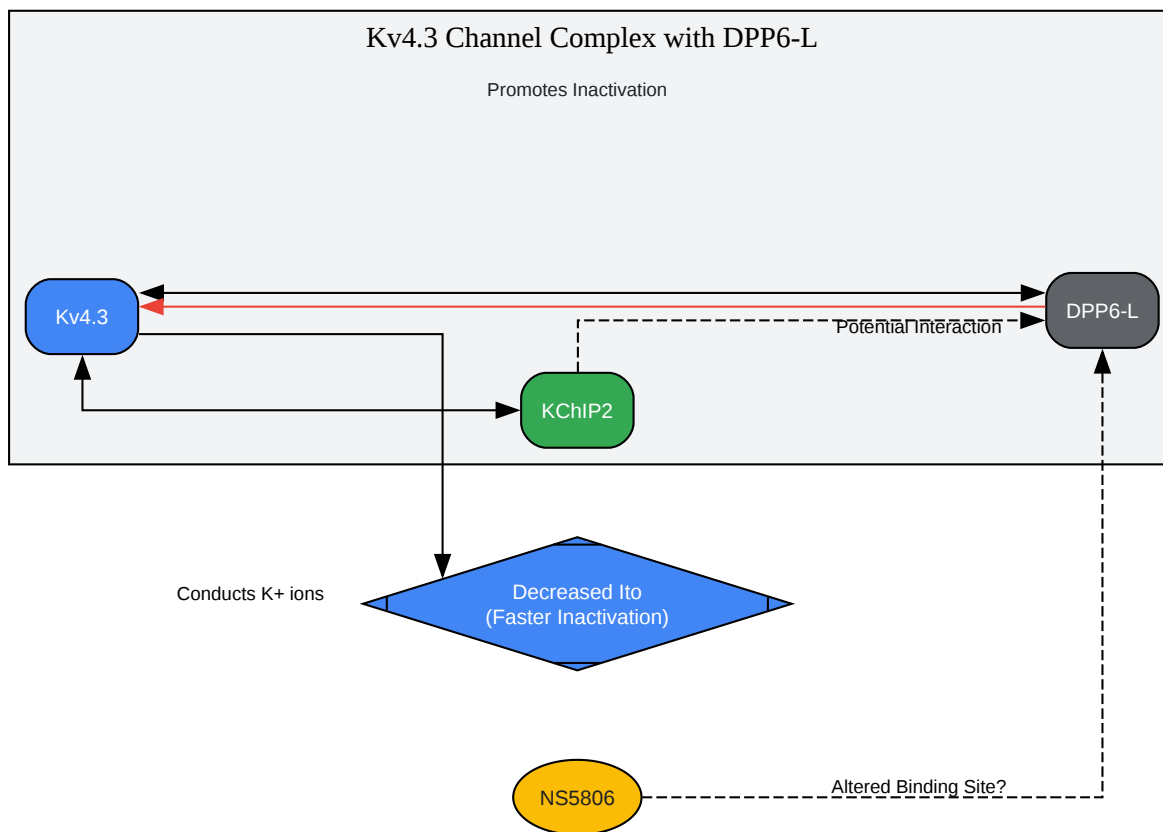

[Click to download full resolution via product page](#)

Caption: Postulated inhibitory mechanism of **NS5806** on the Kv4.3/KChIP2/DPP6-L complex.

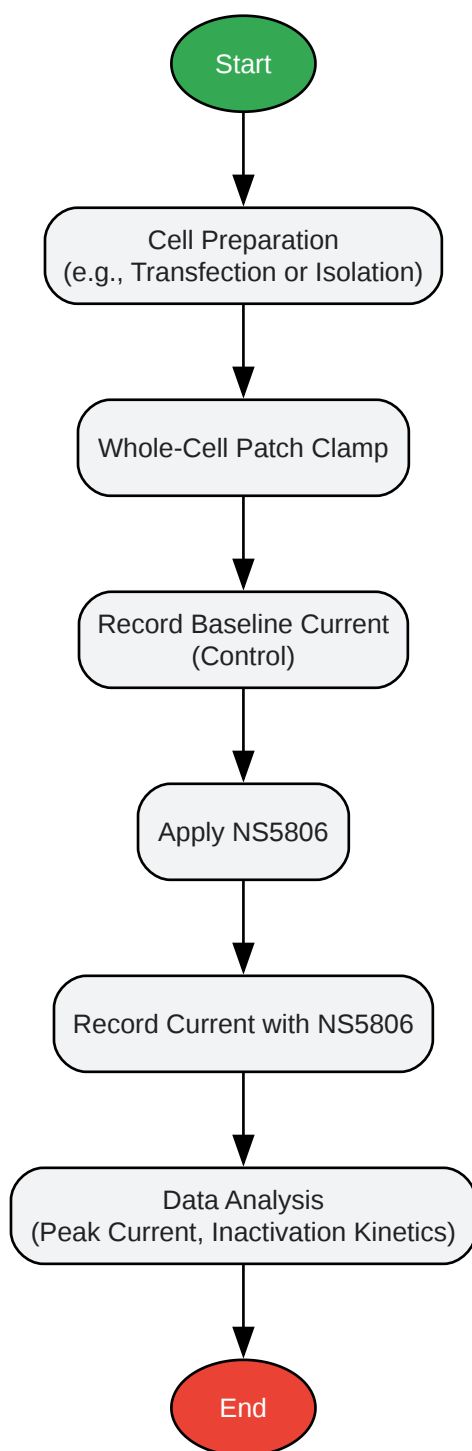

[Click to download full resolution via product page](#)

Caption: General experimental workflow for studying **NS5806** effects.

Need Custom Synthesis?

BenchChem offers custom synthesis for rare earth carbides and specific isotopic labeling.

Email: info@benchchem.com or [Request Quote Online](#).

References

- 1. Modulation of the voltage-gated potassium channel (Kv4.3) and the auxiliary protein (KChIP3) interactions by the current activator NS5806 - PubMed [pubmed.ncbi.nlm.nih.gov]
- 2. Auxiliary subunits control biophysical properties and response to compound NS5806 of the Kv4 potassium channel complex - PMC [pmc.ncbi.nlm.nih.gov]
- 3. Auxiliary subunits control biophysical properties and response to compound NS5806 of the Kv4 potassium channel complex - White Rose Research Online [eprints.whiterose.ac.uk]
- 4. Effect of the I(to) activator NS5806 on cloned K(V)4 channels depends on the accessory protein KChIP2 - PubMed [pubmed.ncbi.nlm.nih.gov]
- 5. file.medchemexpress.com [file.medchemexpress.com]
- 6. Differential effects of the transient outward K(+) current activator NS5806 in the canine left ventricle - PubMed [pubmed.ncbi.nlm.nih.gov]
- 7. NS5806 Induces Electromechanically Discordant Alternans and Arrhythmogenic Voltage-Calcium Dynamics in the Isolated Intact Rabbit Heart - PubMed [pubmed.ncbi.nlm.nih.gov]
- 8. NS5806 Induces Electromechanically Discordant Alternans and Arrhythmogenic Voltage-Calcium Dynamics in the Isolated Intact Rabbit Heart - PMC [pmc.ncbi.nlm.nih.gov]
- 9. docs.axolbio.com [docs.axolbio.com]
- 10. Whole Cell Patch Clamp Protocol | AXOL Bioscience [axolbio.com]
- To cite this document: BenchChem. [An In-depth Technical Guide to the Function of NS5806]. BenchChem, [2026]. [Online PDF]. Available at: [<https://www.benchchem.com/product/b1680101/docs#an-in-depth-technical-guide-to-the-function-of-ns5806>]

Disclaimer & Data Validity:

The information provided in this document is for Research Use Only (RUO) and is strictly not intended for diagnostic or therapeutic procedures. While BenchChem strives to provide

accurate protocols, we make no warranties, express or implied, regarding the fitness of this product for every specific experimental setup.

Technical Support: The protocols provided are for reference purposes. Unsure if this reagent suits your experiment?

Need Industrial/Bulk Grade? [Request Custom Synthesis Quote](#)

BenchChem

Our mission is to be the trusted global source of essential and advanced chemicals, empowering scientists and researchers to drive progress in science and industry.

Contact

Address: 3281 E Guasti Rd

Ontario, CA 91761, United States

Phone: (601) 213-4426

Email: info@benchchem.com

[Contact our Ph.D. Support Team for a compatibility check](#)