

A Comparative Guide to Charge-Transfer Complexes: The Influence of Aromatic Donors

Author: BenchChem Technical Support Team. **Date:** May 2026

Compound of Interest

Compound Name: *N-Tosyl-1-naphthylamine*

CAS No.: 18271-17-5

Cat. No.: B168370

[Get Quote](#)

Introduction: The Dance of Electron Donor and Acceptor

In the realm of molecular interactions, the formation of charge-transfer (CT) complexes represents a fascinating interplay between electron-rich 'donor' molecules and electron-deficient 'acceptor' molecules.[1] This guide provides a comparative analysis of charge-transfer complexes, focusing on how the systematic variation of an aromatic electron donor molecule influences the spectroscopic, thermodynamic, and electronic properties of the resulting complex.

The formation of a CT complex arises from a weak electrostatic attraction between a donor and an acceptor, where a fraction of electronic charge is transferred from the donor's highest occupied molecular orbital (HOMO) to the acceptor's lowest unoccupied molecular orbital (LUMO).[1] This interaction gives rise to new, characteristic absorption bands in the ultraviolet-visible (UV-Vis) spectrum, known as charge-transfer bands, which are not present in the spectra of the individual donor or acceptor molecules.[2] The energy of this CT band is directly related to the ionization potential of the donor and the electron affinity of the acceptor.[3][4]

This guide will delve into the experimental and theoretical underpinnings of CT complex formation, using the well-studied interactions between various aromatic donors and the strong π -acceptor, tetracyanoethylene (TCNE), as a primary example. We will explore how the electron-donating ability of the aromatic ring, modulated by the number and position of methyl substituents, systematically alters the stability and electronic properties of the resulting CT complex. Furthermore, we will provide detailed, field-proven experimental protocols for the synthesis and characterization of these complexes, empowering researchers to conduct their own comparative studies.

The Donor's Influence: A Tale of Methylated Benzenes and TCNE

The series of methylated benzenes—benzene, toluene, the xylenes, mesitylene, and up to hexamethylbenzene—provides an ideal system for studying the effect of donor strength on CT complex formation. With each additional methyl group, the electron density of the aromatic ring increases, making it a better electron donor and lowering its ionization potential.^[5] This systematic change in the donor's electronic properties has a profound and predictable impact on the resulting CT complex with an acceptor like TCNE.

Spectroscopic Properties: A Shift in Color and Energy

The most direct evidence of CT complex formation is the appearance of a new absorption band in the visible region of the electromagnetic spectrum. The position of this charge-transfer band (λ_{max}) is highly sensitive to the nature of the donor. As the number of electron-donating methyl groups on the benzene ring increases, the λ_{max} of the CT band with TCNE shifts to longer wavelengths (a bathochromic or red shift).^[6] This shift indicates a decrease in the energy of the charge-transfer transition (ECT).

The relationship between the energy of the CT transition and the ionization potential of the donor (ID) can be described by the following equation:

$$\text{ECT} = \text{ID} - \text{EA} - C$$

where EA is the electron affinity of the acceptor and C is a term that accounts for the electrostatic interaction in the excited state.^[3] As the donor becomes stronger (lower ID), the

energy required for the charge transfer decreases, resulting in absorption at a longer wavelength.

Thermodynamic Stability: Quantifying the Interaction

The stability of a CT complex in solution is quantified by its formation constant (K_c), which can be determined from UV-Vis spectrophotometric data using the Benesi-Hildebrand equation.[2][7] The thermodynamic parameters of complex formation—enthalpy (ΔH°), Gibbs free energy (ΔG°), and entropy (ΔS°)—provide deeper insight into the driving forces of the interaction. These parameters can be determined by measuring the formation constant at different temperatures.[2][8]

For the series of TCNE complexes with methylated benzenes, a clear trend is observed: as the number of methyl groups increases, the formation constant (K_c) increases, and the enthalpy of formation (ΔH°) becomes more negative.[9][10] This indicates that the complexes become more stable with increasing donor strength. The more negative ΔH° values reflect a stronger interaction between the donor and acceptor.[9]

Comparative Data: TCNE Complexes with Methylated Benzenes

The following table summarizes the experimental data for the 1:1 charge-transfer complexes of tetracyanoethylene (TCNE) with a series of methylated benzene donors in carbon tetrachloride. This data allows for a direct comparison of how the donor's structure affects the spectroscopic and thermodynamic properties of the complex.

Donor	Ionization Potential (eV)	λ_{max} (nm)[9]	Formation Constant, K_c (L/mol) at 25°C[9]	ΔG° (kcal/mol) at 25°C[9]	ΔH° (kcal/mol) [9]	ΔS° (cal/mol·K) [9]
Benzene	9.24	385	0.98	-0.01	-1.8	-6.0
Toluene	8.82	407	1.63	-0.29	-2.4	-7.1
o-Xylene	8.56	432	3.00	-0.65	-3.2	-8.6
m-Xylene	8.56	440	2.78	-0.61	-3.0	-8.0
p-Xylene	8.44	460	3.85	-0.80	-3.6	-9.4
Mesitylene	8.39	463	5.30	-0.99	-4.2	-10.8
Durene	8.03	525	10.5	-1.39	-5.5	-13.8
Hexamethylbenzene	7.85	540	35.5	-2.11	-7.4	-17.7

Experimental Protocols

Synthesis of Charge-Transfer Complexes in Solution (for UV-Vis Analysis)

This protocol describes the preparation of a series of solutions for the determination of the formation constant and molar absorptivity of a charge-transfer complex using the Benesi-Hildebrand method.

Materials:

- Electron Donor (e.g., Mesitylene)
- Electron Acceptor (e.g., Iodine or TCNE)
- Spectroscopic grade solvent (e.g., n-Heptane or Carbon Tetrachloride)

- Volumetric flasks (10 mL)
- Micropipettes

Procedure:

- Prepare a stock solution of the acceptor. Accurately weigh a known amount of the acceptor and dissolve it in the chosen solvent in a volumetric flask to prepare a stock solution of known concentration (e.g., 1×10^{-3} M).
- Prepare a series of donor solutions. Prepare a series of solutions with varying concentrations of the donor in the chosen solvent. The donor concentration should be significantly higher than the acceptor concentration (e.g., 0.1 M to 1.0 M).
- Prepare the sample solutions. In a series of 10 mL volumetric flasks, add a constant volume of the acceptor stock solution (e.g., 1 mL). Then, add a constant volume of each of the different donor solutions to each flask. Finally, dilute to the mark with the solvent. This creates a series of solutions with a constant acceptor concentration and varying donor concentrations.
- Prepare a reference solution. The reference solution should contain the same concentration of the acceptor as the sample solutions, but no donor.

UV-Vis Spectroscopic Analysis and Data Treatment

Instrumentation:

- Dual-beam UV-Vis Spectrophotometer
- Quartz cuvettes (1 cm path length)

Procedure:

- Instrument warm-up. Allow the spectrophotometer to warm up for at least 30 minutes to ensure lamp stability.
- Baseline correction. Record a baseline spectrum with the solvent in both the sample and reference cuvettes.

- Record spectra. Record the UV-Vis absorption spectrum of each sample solution against the reference solution over the desired wavelength range (e.g., 350-700 nm). The new, broad absorption band corresponding to the charge-transfer complex should be observed.
- Data analysis (Benesi-Hildebrand Method). For a 1:1 complex, the following equation can be used:

$$[A]_0 / A = 1 / (Kc\epsilon[D]_0) + 1 / \epsilon$$

where:

- $[A]_0$ is the initial concentration of the acceptor.
- A is the absorbance of the charge-transfer band at λ_{max} .
- Kc is the formation constant.
- ϵ is the molar absorptivity of the complex.
- $[D]_0$ is the initial concentration of the donor.

A plot of $[A]_0 / A$ versus $1 / [D]_0$ should yield a straight line. The formation constant (Kc) can be calculated from the slope and intercept ($Kc = \text{intercept} / \text{slope}$), and the molar absorptivity (ϵ) can be determined from the intercept ($\epsilon = 1 / \text{intercept}$).^[8]

Determination of Thermodynamic Parameters

To determine the enthalpy (ΔH°) and entropy (ΔS°) of complex formation, the UV-Vis measurements are repeated at several different temperatures (e.g., 20°C, 30°C, 40°C, and 50°C). The formation constant (Kc) is calculated for each temperature. The thermodynamic parameters are then obtained from the van't Hoff equation:

$$\ln(Kc) = -\Delta H^\circ / (RT) + \Delta S^\circ / R$$

A plot of $\ln(Kc)$ versus $1/T$ will yield a straight line with a slope of $-\Delta H^\circ/R$ and an intercept of $\Delta S^\circ/R$, where R is the gas constant.^[8]

Visualizing the Concepts

Charge-Transfer Interaction

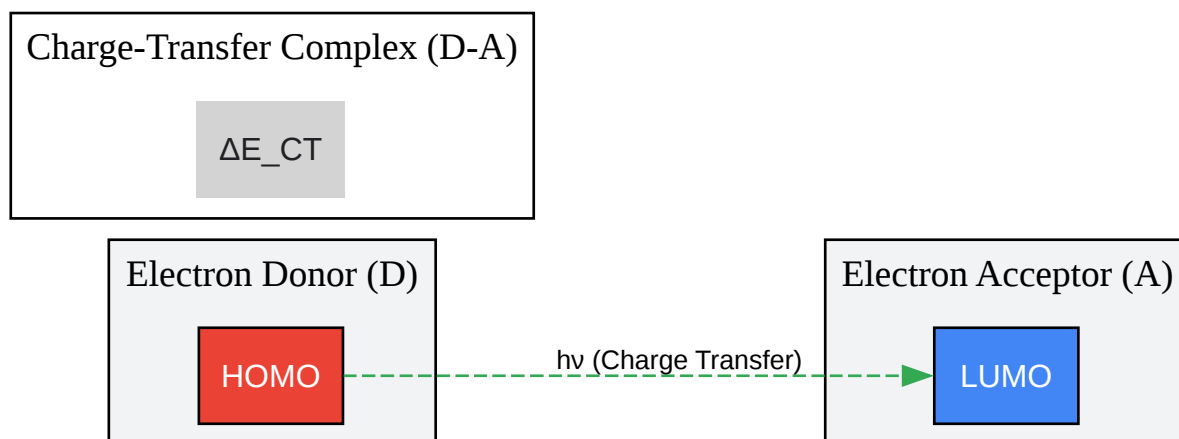

[Click to download full resolution via product page](#)

Caption: Formation of a charge-transfer complex.

Experimental Workflow for Thermodynamic Analysis

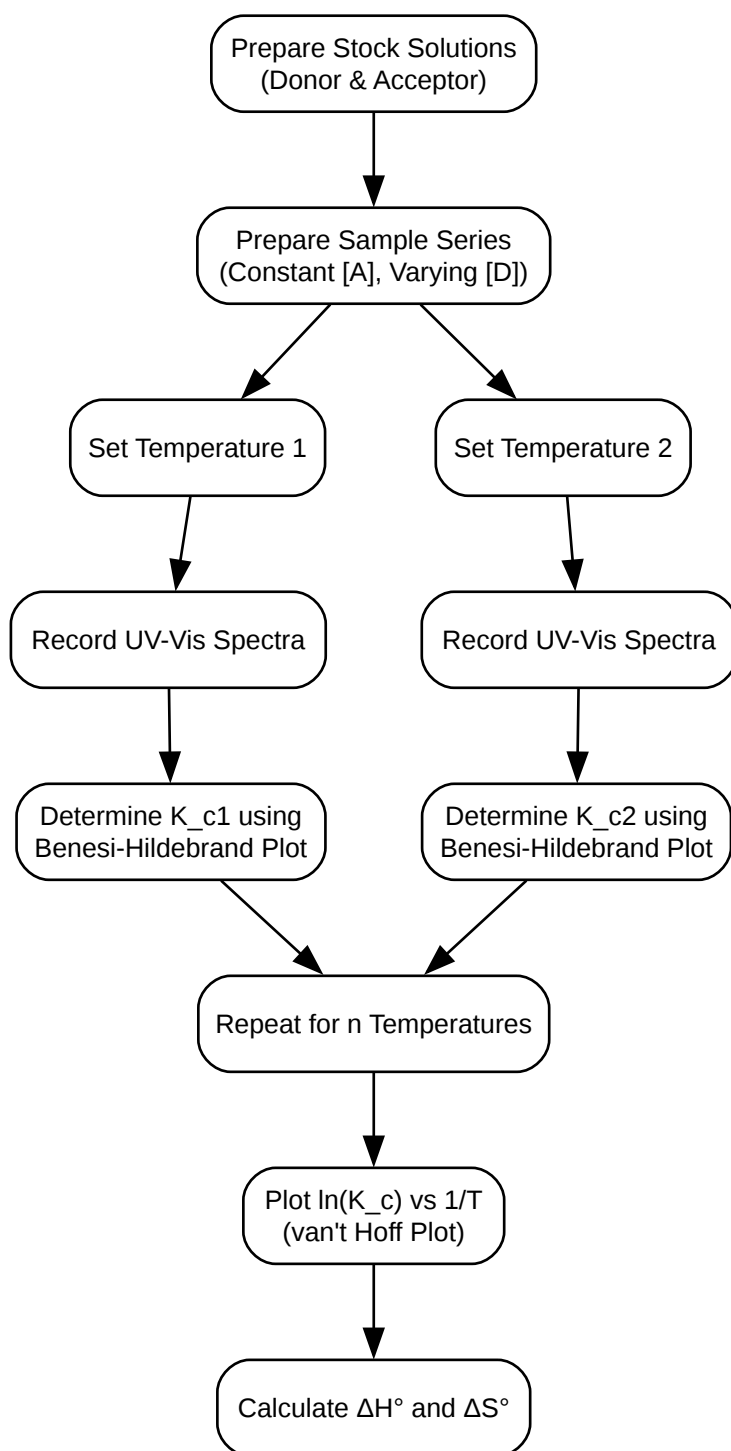

[Click to download full resolution via product page](#)

Caption: Workflow for thermodynamic analysis of CT complexes.

Conclusion: From Fundamental Understanding to Practical Application

The comparative analysis of charge-transfer complexes with varying donors provides a powerful framework for understanding the fundamental principles of non-covalent interactions. As demonstrated with the tetracyanoethylene-methylated benzene series, a systematic modification of the donor's electronic properties leads to predictable and quantifiable changes in the spectroscopic and thermodynamic characteristics of the resulting complex.

The experimental protocols outlined in this guide offer a robust methodology for researchers to explore these relationships in their own systems of interest. A thorough understanding of how donor-acceptor interactions are modulated is not only of academic interest but also has significant implications for various fields, including materials science, drug design, and sensor technology. By mastering the principles and techniques presented here, researchers can better design and control molecular systems with tailored charge-transfer properties for a wide range of applications.

References

- Liao, S. C., & Chan, R. K. (1971). Thermodynamic Constants of Tetracyanoethylene Complexes with Methylated Benzenes. *Canadian Journal of Chemistry*, 49(16), 2700–2705. [\[Link\]](#)
- Chan, R. K., & Liao, S. C. (1970). Dipole moments, charge-transfer parameters, and ionization potentials of the methyl-substituted benzene–tetracyanoethylene complexes. *Canadian Journal of Chemistry*, 48(2), 299–305. [\[Link\]](#)
- Bolovinos, A., et al. (1984). The Methylbenzenes vis-à-vis Benzene Comparison of Their Spectra in the Valence-Shell Transitions Region. *Journal of Molecular Spectroscopy*, 103(1), 63-74. [\[Link\]](#)
- Liao, S. C., & Chan, R. K. (1971). Thermodynamic Constants of Tetracyanoethylene Complexes with Methylated Benzenes. *Canadian Journal of Chemistry*, 49(16), 2700–2705. [\[Link\]](#)

- JETIR. (2018). UV-Visible Spectroscopic Studies of Charge- Transfer Complexes. JETIR, 5(8), 584-589. [\[Link\]](#)
- Blasse, G. (1971). A relation between charge-transfer spectra and ionization potentials. Journal of Inorganic and Nuclear Chemistry, 33(4), 1163-1164. [\[Link\]](#)
- Scite.ai. (2024). Ionization potentials of donors: Significance and symbolism. [\[Link\]](#)
- Marzocco, C. J. (2009). Investigating the Thermodynamics of Charge-Transfer Complexes. A Physical Chemistry Experiment. Journal of Chemical Education, 86(11), 1330. [\[Link\]](#)
- Canadian Science Publishing. (1971). Thermodynamic Constants of Tetracyanoethylene Complexes with Methylated Benzenes. Canadian Journal of Chemistry, 49(16), 2700-2705. [\[Link\]](#)
- Asian Journal of Chemistry. (2010). Study of Stability Constants of Some of the Transition Metal Complexes with β -Diketones by Spectrophotometry. Asian Journal of Chemistry, 22(5), 3451-3456. [\[Link\]](#)
- MDPI. (2020). Charge Transfer Complexes of 1,3,6-Trinitro-9,10-phenanthrenequinone with Polycyclic Aromatic Compounds. Molecules, 25(21), 5035. [\[Link\]](#)
- Wikipedia. (n.d.). Charge-transfer complex. [\[Link\]](#)
- National Center for Biotechnology Information. (2022). Charge Transfer Complex between O-Phenylenediamine and 2, 3-Dichloro-5, 6-Dicyano-1, 4-Benzoquinone: Synthesis, Spectrophotometric, Characterization, Computational Analysis, and its Biological Applications. ACS Omega, 7(20), 17353–17366. [\[Link\]](#)
- Royal Society of Chemistry. (1968). Charge-transfer complexes of some 5-membered heterocyclics and their annellated derivatives with tetracyanoethylene. Transactions of the Faraday Society, 64, 3085-3092. [\[Link\]](#)
- ResearchGate. (2012). Theoretical analysis of charge-transfer electronic spectra of methylated benzenes-TCNE complexes including solvent effects: Approaching experiment. [\[Link\]](#)

- StackExchange. (2016). Why does mesitylene absorb at a longer wavelength than benzene (UV-Vis)? [[Link](#)]
- Duke University Libraries. (2017). Theory and Simulations of Charge Transfer in Engineered Chemical Systems. [[Link](#)]
- Marzzacco, C. (2009). Investigating the Thermodynamics of Charge-Transfer Complexes. A Physical Chemistry Experiment. Journal of Chemical Education, 86(11), 1330. [[Link](#)]
- Chan, R. K., & Liao, S. C. (1970). Dipole moments, charge-transfer parameters, and ionization potentials of the methyl-substituted benzene–tetracyanoethylene complexes. Canadian Journal of Chemistry, 48(2), 299–305. [[Link](#)]

Need Custom Synthesis?

BenchChem offers custom synthesis for rare earth carbides and specific isotopic labeling.

Email: info@benchchem.com or [Request Quote Online](#).

Sources

1. Charge-transfer complex - Wikipedia [en.wikipedia.org]
2. jetir.org [jetir.org]
3. dspace.library.uu.nl [dspace.library.uu.nl]
4. wisdomlib.org [wisdomlib.org]
5. researchgate.net [researchgate.net]
6. chemistry.stackexchange.com [chemistry.stackexchange.com]
7. Charge Transfer Complex between O-Phenylenediamine and 2, 3-Dichloro-5, 6-Dicyano-1, 4-Benzoquinone: Synthesis, Spectrophotometric, Characterization, Computational Analysis, and its Biological Applications - PMC [[pmc.ncbi.nlm.nih.gov](https://pubmed.ncbi.nlm.nih.gov)]
8. researchgate.net [researchgate.net]
9. Sci-Hub. Thermodynamic Constants of Tetracyanoethylene Complexes with Methylated Benzenes / Canadian Journal of Chemistry, 1971 [sci-hub.se]
10. cdnsciencepub.com [cdnsciencepub.com]

- To cite this document: BenchChem. [A Comparative Guide to Charge-Transfer Complexes: The Influence of Aromatic Donors]. BenchChem, [2026]. [Online PDF]. Available at: [<https://www.benchchem.com/product/b168370/docs#a-comparative-guide-to-charge-transfer-complexes-the-influence-of-aromatic-donors>]

Disclaimer & Data Validity:

The information provided in this document is for Research Use Only (RUO) and is strictly not intended for diagnostic or therapeutic procedures. While BenchChem strives to provide accurate protocols, we make no warranties, express or implied, regarding the fitness of this product for every specific experimental setup.

Technical Support: The protocols provided are for reference purposes. Unsure if this reagent suits your experiment?

Need Industrial/Bulk Grade? [Request Custom Synthesis Quote](#)

BenchChem

Our mission is to be the trusted global source of essential and advanced chemicals, empowering scientists and researchers to drive progress in science and industry.

Contact

Address: 3281 E Guasti Rd

Ontario, CA 91761, United States

Phone: (601) 213-4426

Email: info@benchchem.com

[Contact our Ph.D. Support Team for a compatibility check](#)