

PD173074: Application Notes and Protocols for Cell-Based Assays

Author: BenchChem Technical Support Team. **Date:** April 2026

Compound of Interest

Compound Name:	PD173956
CAS No.:	305820-76-2
Cat. No.:	B1679129

[Get Quote](#)

For Researchers, Scientists, and Drug Development Professionals

Introduction

PD173074 is a potent and selective small-molecule inhibitor of Fibroblast Growth Factor Receptors (FGFRs), primarily targeting FGFR1 and FGFR3.[1] It also exhibits inhibitory activity against Vascular Endothelial Growth Factor Receptor 2 (VEGFR2).[1][2] By acting as an ATP-competitive inhibitor, PD173074 effectively blocks the autophosphorylation of these receptors, thereby inhibiting downstream signaling pathways crucial for cell proliferation, survival, differentiation, and angiogenesis.[2] This document provides detailed application notes and protocols for the use of PD173074 in various cell-based assays.

Mechanism of Action

PD173074 binds to the ATP-binding pocket within the kinase domain of FGFRs and VEGFR2. This competitive inhibition prevents the transfer of phosphate from ATP to tyrosine residues on the receptor, a critical step in receptor activation. The blockade of autophosphorylation abrogates the recruitment and activation of downstream signaling proteins, leading to the suppression of key pathways such as the RAS-RAF-MEK-ERK and PI3K-AKT pathways.[3][4]

This ultimately results in reduced cell proliferation, induction of apoptosis, and cell cycle arrest in cancer cells dependent on FGFR signaling.[3]

Quantitative Data

The effective concentration of PD173074 can vary significantly depending on the cell type, the specific assay, and the expression level of target receptors. The following tables summarize the reported 50% inhibitory concentrations (IC50) and other quantitative data for PD173074 in various contexts.

Table 1: In Vitro Kinase and Autophosphorylation Inhibition

Target Kinase	Assay Type	IC50 (nM)
FGFR1	Cell-free kinase assay	~25[5][6]
FGFR1	Autophosphorylation (Cell-based)	1 - 5[6][7]
FGFR3	Cell-free kinase assay	5[2]
VEGFR2	Cell-free kinase assay	~100 - 200[2][5]
VEGFR2	Autophosphorylation (Cell-based)	100 - 200[5][7]
PDGFR	Cell-free kinase assay	17,600[2]
c-Src	Cell-free kinase assay	19,800[2]
EGFR	Cell-free kinase assay	> 50,000[2]
InsR	Cell-free kinase assay	> 50,000[2]
MEK	Cell-free kinase assay	> 50,000[2]
PKC	Cell-free kinase assay	> 50,000[2]

Table 2: Cell-Based Assay IC50 Values

Cell Line	Cancer Type	Assay Type	IC50
NCI-H1581	Lung Cancer	Growth Inhibition	12.25 nM[5]
KG-1	Leukemia	Growth Inhibition	51.29 nM[5]
MFM-223	Breast Cancer	Growth Inhibition	215.76 nM[5]
KMS11, KMS18	Multiple Myeloma	Cell Viability	< 20 nM[5][7]
TFK-1	Cholangiocarcinoma	Cell Viability	~6.6 μ M[8]
KKU-213	Cholangiocarcinoma	Cell Viability	~8.4 μ M[8]
RBE	Cholangiocarcinoma	Cell Viability	~11 μ M[8]
KKU-100	Cholangiocarcinoma	Cell Viability	~16 μ M[8]

Signaling Pathway and Experimental Workflow

To visually represent the mechanism of action and a typical experimental workflow, the following diagrams have been generated.

FGFR Signaling Pathway Inhibition by PD173074

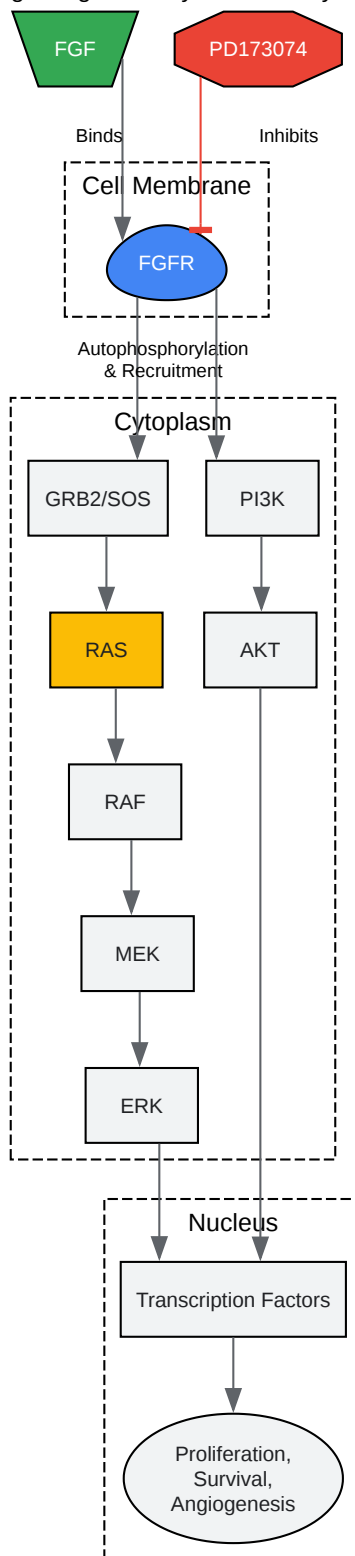

[Click to download full resolution via product page](#)

FGFR Signaling Pathway Inhibition by PD173074.

General Workflow for Cell-Based Assays with PD173074

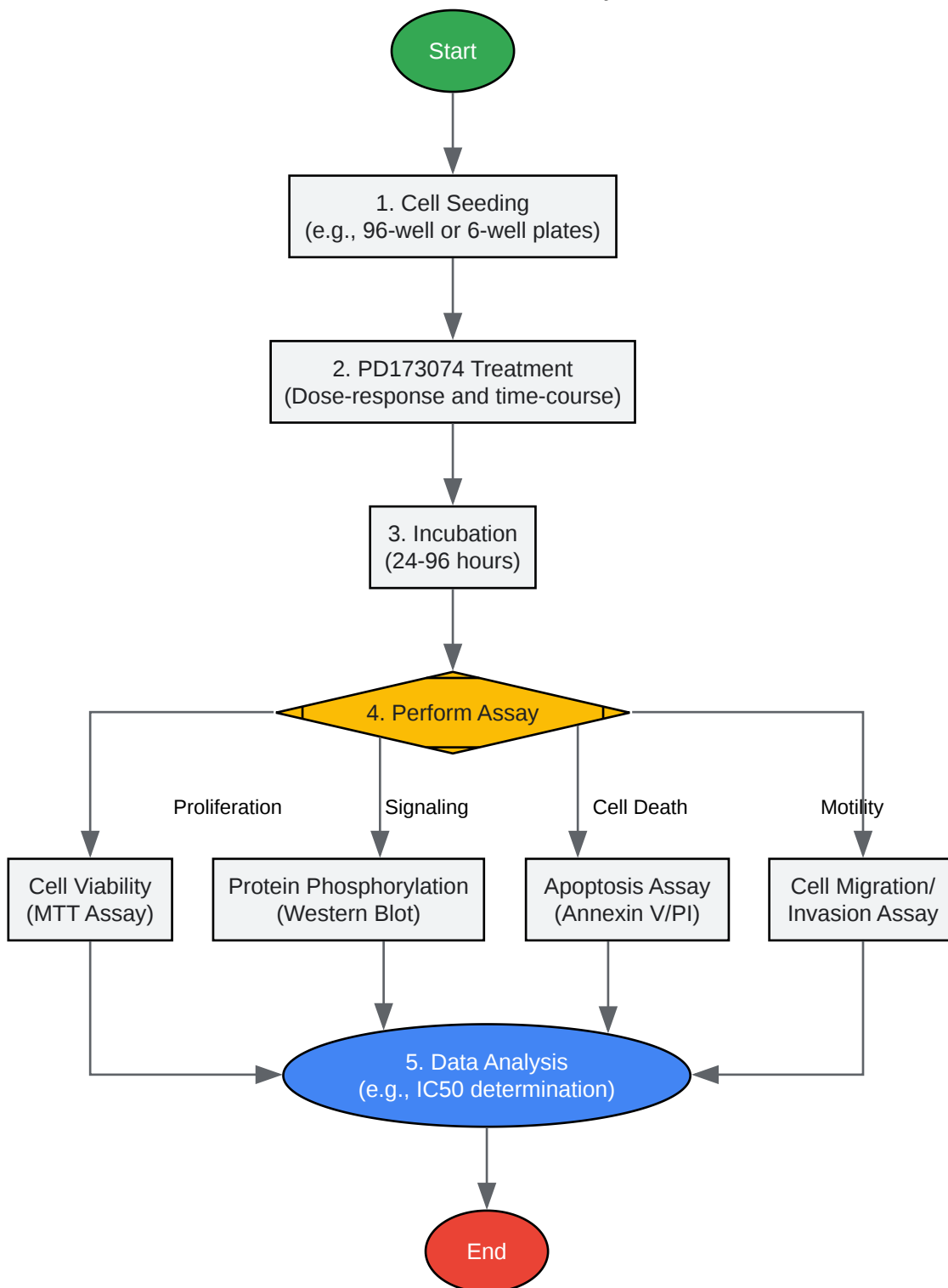

[Click to download full resolution via product page](#)

General Workflow for Cell-Based Assays with PD173074.

Experimental Protocols

Protocol 1: Cell Viability Assay (MTT Assay)

This protocol provides a general guideline for determining the effect of PD173074 on cell viability using an MTT assay.

Materials:

- Cells of interest
- Complete cell culture medium
- PD173074 stock solution (e.g., 10 mM in DMSO)
- 96-well cell culture plates
- MTT (3-(4,5-dimethylthiazol-2-yl)-2,5-diphenyltetrazolium bromide) solution (5 mg/mL in PBS)
- DMSO (Dimethyl sulfoxide)
- Microplate reader

Procedure:

- Seed cells in a 96-well plate at a density of 5,000-10,000 cells per well and allow them to adhere overnight.[8]
- Prepare serial dilutions of PD173074 in a complete culture medium from the stock solution. A common concentration range to test is 0.1 nM to 100 μ M.[9]
- Remove the medium from the wells and replace it with the medium containing the different concentrations of PD173074. Include a vehicle control (DMSO) at the same final concentration.
- Incubate the plate for 24-96 hours at 37°C in a humidified incubator with 5% CO₂.[8]

- After the incubation period, add 10-20 μL of MTT solution to each well and incubate for 2-4 hours at 37°C, allowing for the formation of formazan crystals.[1][9]
- Carefully remove the medium and add 100-150 μL of DMSO to each well to dissolve the formazan crystals.[1][9]
- Measure the absorbance at 540 nm or 570 nm using a microplate reader.[1][9]
- Calculate the percentage of cell viability relative to the vehicle control and plot the results to determine the IC50 value.

Protocol 2: Western Blot Analysis of FGFR Phosphorylation

This protocol is used to assess the effect of PD173074 on the phosphorylation status of FGFR and downstream signaling proteins like ERK.

Materials:

- Cells of interest
- PD173074 stock solution
- 6-well plates
- Ice-cold PBS
- RIPA lysis buffer with protease and phosphatase inhibitors
- BCA protein assay kit
- SDS-PAGE gels and running buffer
- PVDF or nitrocellulose membranes
- Blocking buffer (e.g., 5% non-fat milk or BSA in TBST)

- Primary antibodies (e.g., anti-phospho-FGFR, anti-total-FGFR, anti-phospho-ERK, anti-total-ERK)
- HRP-conjugated secondary antibodies
- Chemiluminescent substrate and imaging system

Procedure:

- Seed cells in 6-well plates and grow to 70-80% confluency.
- Serum-starve the cells overnight if necessary to reduce basal receptor phosphorylation.
- Pre-treat the cells with various concentrations of PD173074 (e.g., 10 nM, 50 nM, 1 μ M) for 1-2 hours.[\[9\]](#)
- Stimulate the cells with an appropriate FGF ligand if required to induce receptor phosphorylation.
- Wash the cells with ice-cold PBS and lyse them on ice with RIPA buffer.[\[1\]](#)
- Determine the protein concentration of the lysates using a BCA protein assay.[\[1\]](#)
- Separate equal amounts of protein (e.g., 20-30 μ g) by SDS-PAGE and transfer them to a PVDF or nitrocellulose membrane.[\[1\]](#)
- Block the membrane with blocking buffer for 1 hour at room temperature.
- Incubate the membrane with the primary antibody overnight at 4°C.[\[1\]](#)
- Wash the membrane and incubate with the HRP-conjugated secondary antibody for 1 hour at room temperature.[\[1\]](#)
- Detect the protein bands using a chemiluminescent substrate and an imaging system.[\[1\]](#)
- Analyze the band intensities to determine the effect of PD173074 on protein phosphorylation relative to the total protein levels.[\[1\]](#)

Protocol 3: Apoptosis Assay (Annexin V/Propidium Iodide Staining)

This flow cytometry-based assay is used to quantify apoptosis induced by PD173074.

Materials:

- Cells of interest
- PD173074 stock solution
- 6-well plates
- Annexin V-FITC Apoptosis Detection Kit
- Flow cytometer

Procedure:

- Seed cells in 6-well plates and treat with various concentrations of PD173074 for a specified time (e.g., 48 hours).[\[1\]](#)
- Harvest both adherent and floating cells and wash them with cold PBS.[\[1\]](#)
- Resuspend the cells in 1X Annexin V binding buffer.[\[1\]](#)
- Add FITC-conjugated Annexin V and Propidium Iodide (PI) staining solution according to the manufacturer's protocol.[\[1\]](#)
- Incubate the cells for 15 minutes at room temperature in the dark.[\[1\]](#)
- Analyze the stained cells by flow cytometry. Annexin V-positive/PI-negative cells are considered early apoptotic, while Annexin V-positive/PI-positive cells are in late apoptosis or necrosis.[\[1\]](#)

Protocol 4: Cell Migration (Wound Healing) Assay

This assay assesses the effect of PD173074 on cell migration.

Materials:

- Cells of interest
- PD173074 stock solution
- 6-well plates or other suitable culture dishes
- Sterile 200 μ L pipette tip or a wound-healing insert
- Microscope with a camera

Procedure:

- Seed cells in a 6-well plate and grow them to a confluent monolayer.
- Create a "scratch" or wound in the monolayer using a sterile pipette tip.
- Wash the wells with PBS to remove detached cells.
- Replace the medium with a fresh medium containing various concentrations of PD173074 or a vehicle control.
- Capture images of the wound at time 0 and at regular intervals (e.g., 12, 24, 48 hours).
- Measure the width of the wound at different points for each condition and time point.
- Calculate the percentage of wound closure to determine the effect of PD173074 on cell migration.

Protocol 5: In Vitro Angiogenesis (Tube Formation)

Assay

This assay models the formation of capillary-like structures by endothelial cells and is used to evaluate the anti-angiogenic potential of PD173074.

Materials:

- Human Umbilical Vein Endothelial Cells (HUVECs)
- PD173074 stock solution
- 96-well plate
- Matrigel
- Endothelial cell basal medium
- Angiogenic stimulus (e.g., bFGF or VEGF)
- Microscope with a camera

Procedure:

- Thaw Matrigel on ice and coat the wells of a 96-well plate. Incubate at 37°C for 30-60 minutes to allow solidification.[6]
- Harvest HUVECs and resuspend them in a basal medium containing the desired concentrations of PD173074 and an angiogenic stimulus.[6]
- Seed the HUVEC suspension onto the solidified Matrigel.[6]
- Incubate for 6-18 hours at 37°C to allow for the formation of tube-like structures.[6]
- Capture images using a microscope.
- Quantify the extent of tube formation by measuring parameters such as the number of junctions, total tube length, and number of loops.

Conclusion

PD173074 is a valuable research tool for investigating the roles of FGFR and VEGFR signaling in various biological processes. The protocols and data presented in this document provide a comprehensive guide for researchers to effectively design and execute cell-based assays using this potent inhibitor. It is crucial to optimize the experimental conditions, including cell type and inhibitor concentration, to achieve reliable and reproducible results.

Need Custom Synthesis?

BenchChem offers custom synthesis for rare earth carbides and specific isotopic labeling.

Email: info@benchchem.com or [Request Quote Online](#).

References

- [1. benchchem.com \[benchchem.com\]](#)
- [2. benchchem.com \[benchchem.com\]](#)
- [3. benchchem.com \[benchchem.com\]](#)
- [4. researchgate.net \[researchgate.net\]](#)
- [5. selleckchem.com \[selleckchem.com\]](#)
- [6. benchchem.com \[benchchem.com\]](#)
- [7. benchchem.com \[benchchem.com\]](#)
- [8. Targeting FGFRs Using PD173074 as a Novel Therapeutic Strategy in Cholangiocarcinoma | MDPI \[mdpi.com\]](#)
- [9. benchchem.com \[benchchem.com\]](#)
- To cite this document: BenchChem. [PD173074: Application Notes and Protocols for Cell-Based Assays]. BenchChem, [2026]. [Online PDF]. Available at: [\[https://www.benchchem.com/product/b1679129/docs#pd173074-application-notes-and-protocols-for-cell-based-assays\]](https://www.benchchem.com/product/b1679129/docs#pd173074-application-notes-and-protocols-for-cell-based-assays)

Disclaimer & Data Validity:

The information provided in this document is for Research Use Only (RUO) and is strictly not intended for diagnostic or therapeutic procedures. While BenchChem strives to provide accurate protocols, we make no warranties, express or implied, regarding the fitness of this product for every specific experimental setup.

Technical Support: The protocols provided are for reference purposes. Unsure if this reagent suits your experiment?

Need Industrial/Bulk Grade? [Request Custom Synthesis Quote](#)

BenchChem

Our mission is to be the trusted global source of essential and advanced chemicals, empowering scientists and researchers to drive progress in science and industry.

Contact

Address: 3281 E Guasti Rd

Ontario, CA 91761, United States

Phone: (601) 213-4426

Email: info@benchchem.com

[Contact our Ph.D. Support Team for a compatibility check](#)