

A Comparative Guide to Analytical Methods for Procyclidine Hydrochloride

Author: BenchChem Technical Support Team. **Date:** April 2026

Compound of Interest

Compound Name: Procyclidine hydrochloride

CAS No.: 32381-60-5

Cat. No.: B1679154

[Get Quote](#)

For researchers, scientists, and drug development professionals, the accurate and precise quantification of **Procyclidine hydrochloride** is paramount for ensuring product quality and therapeutic efficacy. This guide provides a comprehensive cross-validation of various analytical methods, presenting their performance data, detailed experimental protocols, and a visual representation of the validation workflow.

Comparative Performance of Analytical Methods

The selection of an appropriate analytical method for **Procyclidine hydrochloride** depends on the specific requirements of the analysis, such as the nature of the sample (bulk drug, pharmaceutical formulation, or biological matrix), the required sensitivity, and the available instrumentation. The following table summarizes the key performance parameters of commonly employed analytical techniques.

Analytical Method	Linearity Range	Accuracy (% Recovery)	Precision (%RSD)	Limit of Detection (LOD)	Limit of Quantitation (LOQ)	Key Advantages
RP-HPLC	2-200 µg/mL[1][2]	99.20 - 100.66%[1]	< 2%[1][2]	0.6 µg/mL[1]	2.0 µg/mL[1]	Simple, rapid, precise, and suitable for routine quality control.[1]
Derivative UV Spectrometry	Not explicitly stated, but sufficient for quantitative work.[3]	Results are well within the official limits of 90.0 to 110.0%. [3]	Not explicitly stated.	Not explicitly stated.	Not explicitly stated.	Minimizes interference from excipients. [3]
LC-MS/MS	0.5 - 120 ng/mL[4]	Average recovery of 91.118%. [5]	Not explicitly stated.	Not explicitly stated.	0.1 ng/mL[5]	High selectivity and sensitivity, ideal for bioanalytical studies. [4][5]
Gas Chromatography (GC)	Not explicitly stated.	Not explicitly stated.	Not explicitly stated.	Not explicitly stated.	Not explicitly stated.	Suitable for analysis in biological matrices like plasma and urine. [6]

	Not explicitly stated, but used for assay.	Not explicitly stated.	Not explicitly stated.	Not explicitly stated.	Not explicitly stated.	Simple and cost-effective for basic quantification.
--	--	------------------------	------------------------	------------------------	------------------------	---

Experimental Protocols

Detailed methodologies for the key analytical techniques are provided below to facilitate replication and cross-validation in your laboratory.

Reverse-Phase High-Performance Liquid Chromatography (RP-HPLC)

This method is suitable for the quantitative estimation of **Procyclidine hydrochloride** in pharmaceutical dosage forms.[\[1\]](#)

- Instrumentation: A liquid chromatograph equipped with a UV detector.
- Column: Chiral-AGP, 100 x 4.0 mm, 5.0 μm analytical column.[\[1\]](#)[\[2\]](#)
- Mobile Phase: A mixture of 10 mM sodium acetate (pH 4.1, adjusted with acetic acid) and acetonitrile in a ratio of 95:5 (v/v).[\[1\]](#)[\[2\]](#)
- Flow Rate: 1.0 mL/min.[\[1\]](#)[\[2\]](#)
- Column Temperature: 30°C.[\[1\]](#)[\[2\]](#)
- Detection Wavelength: 210 nm.[\[1\]](#)[\[2\]](#)
- Standard Solution Preparation: Dissolve 25 mg of **Procyclidine Hydrochloride** Reference Standard (RS) in water in a 100 mL volumetric flask. Dilute 10.0 mL of this solution to 100 mL with a Bromocresol purple solution to get a concentration of 25 $\mu\text{g/mL}$.[\[1\]](#)
- Sample Preparation (Tablets): Weigh and finely powder 20 tablets. Transfer a portion of the powder equivalent to about 2.5 mg of **Procyclidine hydrochloride** to a 100 mL volumetric

flask, add 10 mL of water, and mix.[1]

Derivative UV Spectrometry

This technique is a rapid alternative to titration methods for the assay of **Procyclidine hydrochloride** in tablets and injections, effectively minimizing interference from excipients.[3]

- Instrumentation: A scanning UV/visible spectrometer.
- Solvent: 0.1 M Hydrochloric acid.[3]
- Spectral Range: 220 to 280 nm for second-derivative spectra.[7]
- Measurement: Measure the amplitude from the largest trough at about 257 nm to the largest peak at about 254 nm.[7]
- Standard Solution Preparation: Prepare a solution containing about 0.025% w/v of **Procyclidine hydrochloride** in 0.1 M hydrochloric acid.[3]
- Sample Preparation (Tablets): Weigh and powder 20 tablets. Transfer an amount of powder equivalent to about 25 mg of **Procyclidine hydrochloride** into a 100 mL volumetric flask. Add about 80 mL of 0.1 M hydrochloric acid, sonicate for 15 minutes, cool, and dilute to volume with the same solvent. Filter the solution.[3][7]

Liquid Chromatography-Tandem Mass Spectrometry (LC-MS/MS)

A highly sensitive and selective method for the quantification of Procyclidine in human plasma, making it ideal for pharmacokinetic studies.[4][5]

- Instrumentation: A liquid chromatograph coupled with a tandem mass spectrometer.
- Column: Zodiac C18 column (50 × 4.6 mm, 5 μm).[4]
- Mobile Phase: A mixture of methanol and 0.1% formic acid in water (70:30, v/v).[4]
- Flow Rate: 1.0 mL/min.[4]

- Detection: Multiple reaction monitoring (MRM) in positive ion mode.[4]
- Sample Preparation: Liquid-liquid extraction of plasma samples with methyl tertiary butyl ether.[4]

Gas Chromatography (GC)

This method is suitable for the analysis of Procyclidine in biological fluids such as plasma and urine.[6] While specific validation parameters were not detailed in the reviewed literature, GC-based methods are well-established for drug analysis. For detection in cases of drug abuse, GC-Mass Spectrometry (GC-MS) is employed, targeting mono-hydroxy metabolites of Procyclidine.[8]

- Instrumentation: Gas chromatograph, potentially coupled with a mass spectrometer (GC-MS).
- Sample Preparation: Typically involves liquid-liquid extraction of the biological sample.[9][10] For urine analysis, extraction is performed under basic pH conditions.[8]

Visualizing the Cross-Validation Workflow

The following diagram illustrates a typical workflow for the cross-validation of analytical methods for **Procyclidine hydrochloride**.

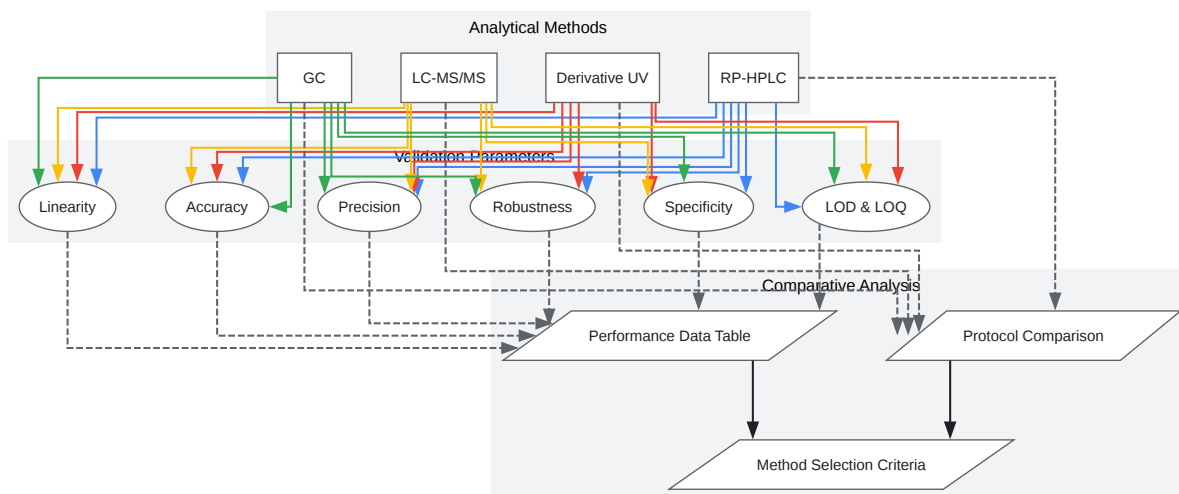

[Click to download full resolution via product page](#)

Caption: Workflow for cross-validation of analytical methods for Procyclidine HCl.

Signaling Pathway of Procyclidine Hydrochloride

Procyclidine hydrochloride exerts its therapeutic effect primarily through its action as an anticholinergic agent, specifically as an antagonist at muscarinic acetylcholine receptors.

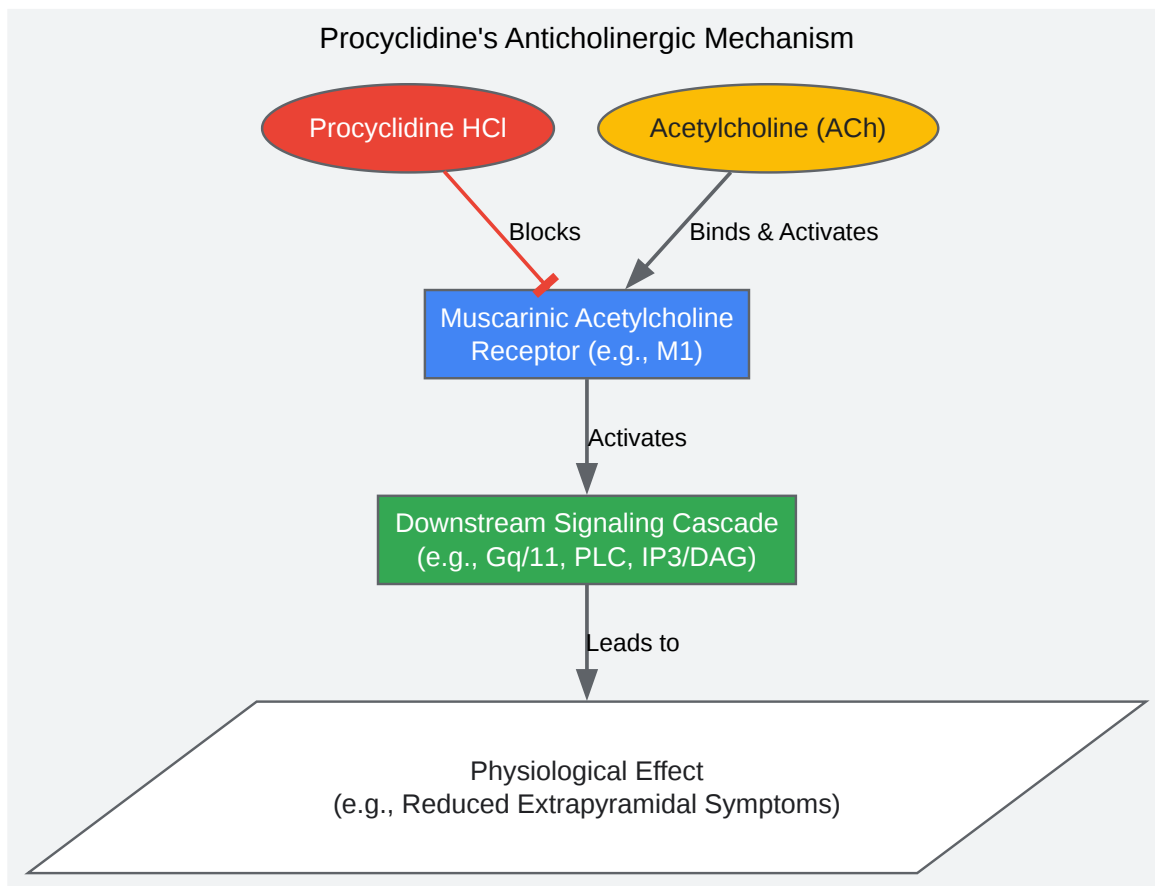

[Click to download full resolution via product page](#)

Caption: Antagonistic action of Procyclidine at muscarinic acetylcholine receptors.

Need Custom Synthesis?

BenchChem offers custom synthesis for rare earth carbides and specific isotopic labeling.

Email: info@benchchem.com or [Request Quote Online](#).

References

- 1. ijbmsp.org [ijbmsp.org]
- 2. ijbmsp.org [ijbmsp.org]

- [3. academic.oup.com \[academic.oup.com\]](https://academic.oup.com)
- [4. Bioanalytical method for estimation of procyclidine in human plasma using liquid chromatography-tandem mass spectrometry: Application to pharmacokinetic study - PubMed \[pubmed.ncbi.nlm.nih.gov\]](#)
- [5. actascientific.com \[actascientific.com\]](https://actascientific.com)
- [6. Analysis of procyclidine in human plasma and urine by gas-liquid chromatography - PubMed \[pubmed.ncbi.nlm.nih.gov\]](#)
- [7. drugfuture.com \[drugfuture.com\]](https://drugfuture.com)
- [8. Target urinary analytes for the gas chromatographic- mass spectrometric detection of procyclidine and benzhexol in drug abuse cases - PubMed \[pubmed.ncbi.nlm.nih.gov\]](#)
- [9. mdpi.com \[mdpi.com\]](https://mdpi.com)
- [10. encyclopedia.pub \[encyclopedia.pub\]](https://encyclopedia.pub)
- To cite this document: BenchChem. [A Comparative Guide to Analytical Methods for Procyclidine Hydrochloride]. BenchChem, [2026]. [Online PDF]. Available at: [\[https://www.benchchem.com/product/b1679154/docs#a-comparative-guide-to-analytical-methods-for-procyclidine-hydrochloride\]](https://www.benchchem.com/product/b1679154/docs#a-comparative-guide-to-analytical-methods-for-procyclidine-hydrochloride)

Disclaimer & Data Validity:

The information provided in this document is for Research Use Only (RUO) and is strictly not intended for diagnostic or therapeutic procedures. While BenchChem strives to provide accurate protocols, we make no warranties, express or implied, regarding the fitness of this product for every specific experimental setup.

Technical Support: The protocols provided are for reference purposes. Unsure if this reagent suits your experiment?

Need Industrial/Bulk Grade? [Request Custom Synthesis Quote](#)

BenchChem

Our mission is to be the trusted global source of essential and advanced chemicals, empowering scientists and researchers to drive progress in science and industry.

Contact

Address: 3281 E Guasti Rd

Ontario, CA 91761, United States

Phone: (601) 213-4426

Email: info@benchchem.com

[Contact our Ph.D. Support Team for a compatibility check](#)