

Application Notes and Protocols for Gene Expression Analysis Following Panduratin A Treatment

Author: BenchChem Technical Support Team. **Date:** April 2026

Compound of Interest

Compound Name:	Panduratin A
CAS No.:	89837-52-5
Cat. No.:	B1678376

[Get Quote](#)

For Researchers, Scientists, and Drug Development Professionals

Introduction

Panduratin A, a natural chalcone isolated from the rhizomes of *Boesenbergia rotunda* (fingerroot), has garnered significant scientific interest due to its diverse pharmacological activities.^[1] Emerging research has highlighted its potent anti-cancer, anti-inflammatory, and antiviral properties.^{[2][3][4]} These effects are largely attributed to its ability to modulate various signaling pathways and, consequently, alter gene expression profiles within treated cells. Understanding the specific genes and pathways affected by **Panduratin A** is crucial for elucidating its mechanism of action and for the development of novel therapeutic strategies.

These application notes provide a comprehensive overview of the effects of **Panduratin A** on gene expression and offer detailed protocols for researchers to conduct their own analyses. The information is intended to guide the design of experiments aimed at identifying and validating molecular targets of **Panduratin A** in various disease models.

Data Presentation: Quantitative Effects of Panduratin A

The following tables summarize the quantitative data on the cytotoxic and gene regulatory effects of **Panduratin A** across different cell lines as reported in the literature.

Table 1: Cytotoxicity of **Panduratin A** (IC50 Values)

Cell Line	Cell Type	IC50 Value	Reference
A549	Non-small cell lung cancer	6.03 ± 0.21 µg/mL	[5]
H1975	Non-small cell lung cancer (EGFR T790M mutant)	5.58 ± 0.15 µg/mL	[5]
MRC5	Normal lung fibroblast	12.96 ± 0.36 µg/mL	[5]
MCF-7	Breast cancer	15 µM (24h), 11.5 µM (48h)	[2]
T47D	Breast cancer	17.5 µM (24h), 14.5 µM (48h)	[2]
PANC-1	Pancreatic cancer (nutrient-deprived)	1.6 µM	[6]
iPSC-CMs	iPSC-derived cardiomyocytes	10.09 µM (CC50)	[4][7]

Table 2: Effects of **Panduratin A** on Gene and Protein Expression

Target Gene/Protein	Cell Line/Model	Effect	Method	Reference
p-EGFR	A549, H1975	Inhibition of phosphorylation	Western Blot	[5]
p-STAT3	A549, H1975	Inhibition of phosphorylation	Western Blot	[5]
p-Akt	A549, H1975	Inhibition of phosphorylation	Western Blot	[5]
NF- κ B	A549	Inhibition of nuclear translocation	High Content Screening	[8]
Caspase-3	A549	Activation	Assay	[1]
MMP-2	A549	Reduction of secretion	Gelatin Zymography	[1]
p53, p21	A549	Elevation	Not specified	[1]
Cyclin D1, CDK4	MCF-7	Downregulation	Immunoblot	[9]
p21WAF1/Cip1, p27Kip1	MCF-7	Induction	Immunoblot	[9]
Bax:Bcl-2 ratio	MCF-7	Increase	Not specified	[9]
IL-6, MCP-1	TNF- α stimulated endothelial cells	Reduction of level	Not specified	[3][10]
ICAM-1, VCAM-1	TNF- α stimulated endothelial cells	Inhibition of expression	Not specified	[3][10]
iNOS, COX-2	LPS-stimulated RAW264.7 macrophages	Suppression of expression	Western Blot	[11]
TNF- α , IL-1 β , IL-6 (mRNA)	LPS-stimulated SIMA9 microglia	Decreased expression	Not specified	[12]

IL-4, IL-10	LPS-stimulated SIMA9 microglia	Increased release	Not specified	[12]
IL-1 β , NF- κ B	LPS-stimulated HGF-1	Reduced expression	Not specified	[13]
MMP-2, MMP-8	LPS-stimulated HGF-1	Inhibition	Not specified	[13]

Signaling Pathways Modulated by Panduratin A

Panduratin A has been shown to interfere with key signaling cascades that are often dysregulated in disease. The following diagrams illustrate the points of intervention by **Panduratin A** in two major pathways.

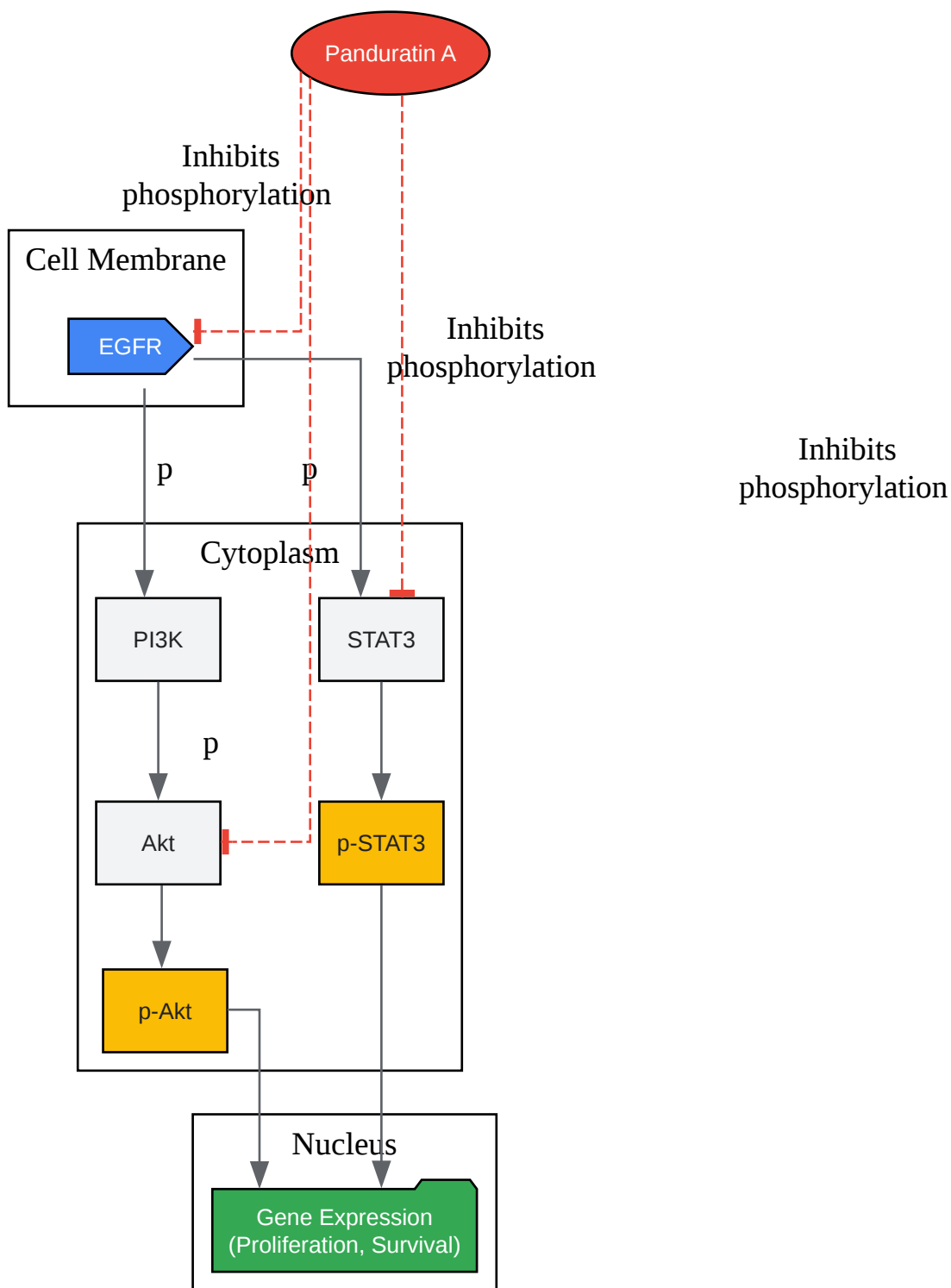

[Click to download full resolution via product page](#)

Caption: EGFR/STAT3/Akt signaling pathway inhibition by **Panduratin A**.

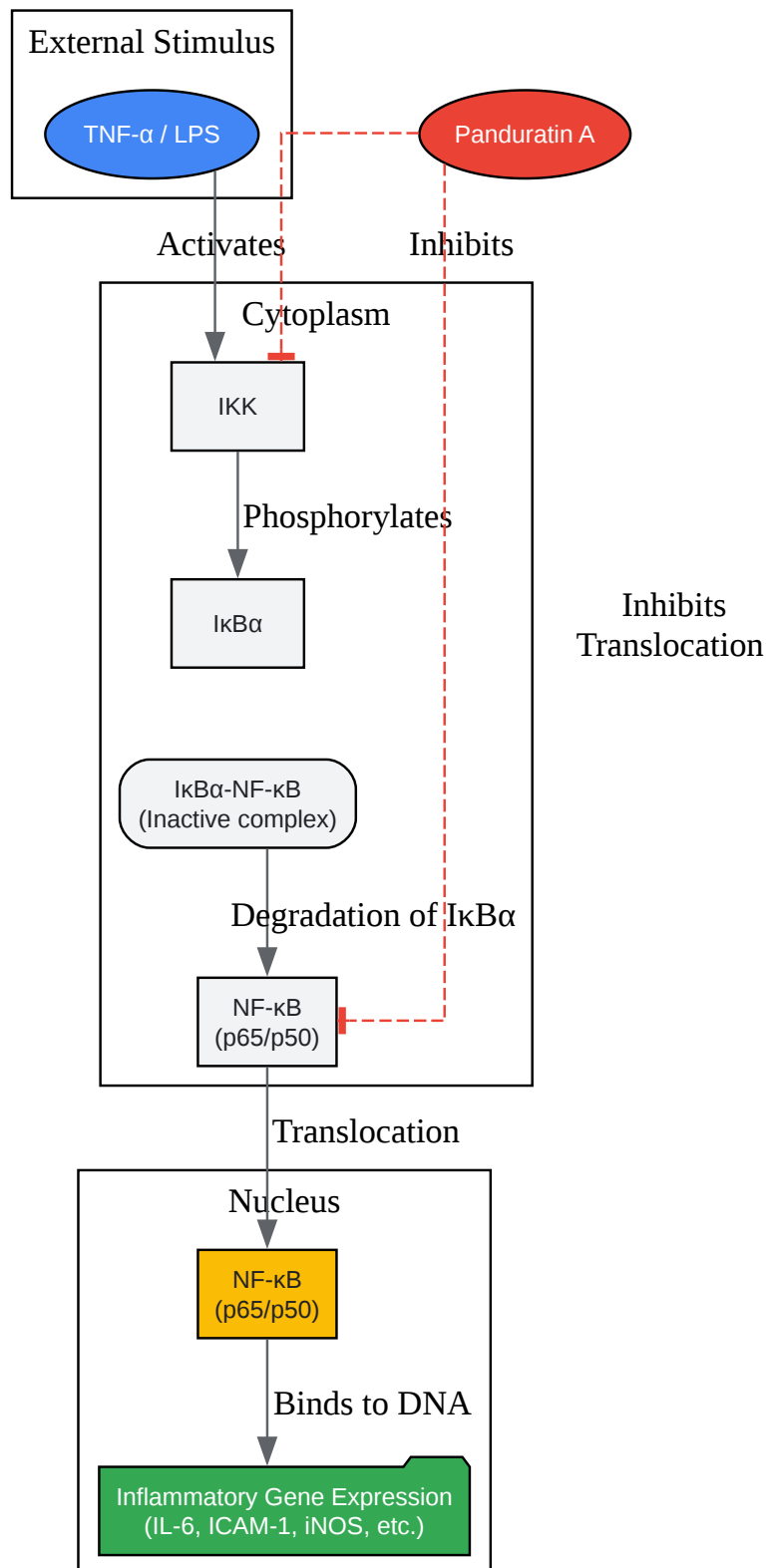

[Click to download full resolution via product page](#)

Caption: NF-κB signaling pathway inhibition by **Panduratin A**.

Experimental Workflow and Protocols

A general workflow for investigating the effects of **Panduratin A** on gene expression is outlined below. This is followed by detailed protocols for key experimental procedures.

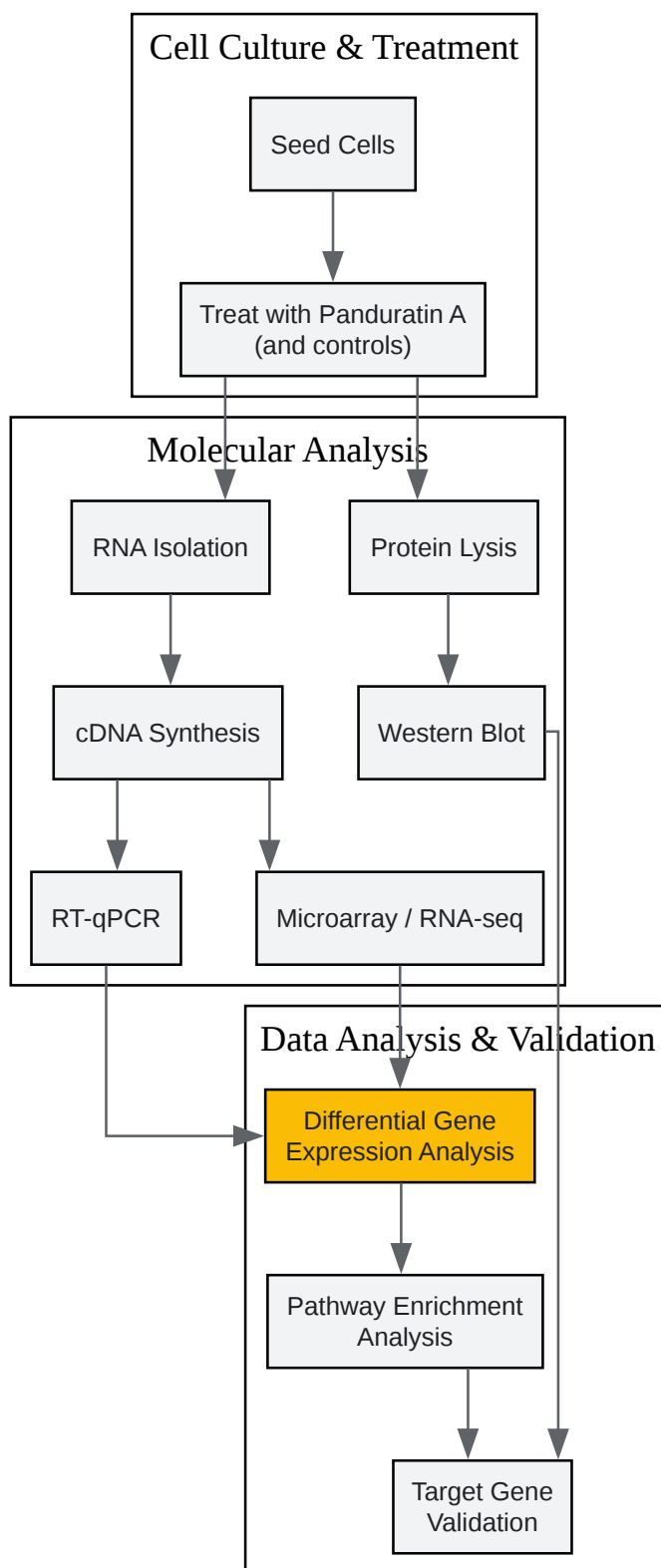

[Click to download full resolution via product page](#)

Caption: General experimental workflow for gene expression analysis.

Protocol 1: Cell Culture and Panduratin A Treatment

- Cell Seeding:
 - Culture selected cell lines (e.g., A549, MCF-7) in appropriate media and conditions as recommended by the supplier (e.g., ATCC).
 - Seed cells in multi-well plates (e.g., 6-well or 96-well) at a density that allows for logarithmic growth during the treatment period. For A549 cells, a density of 2×10^5 cells/well in a 6-well plate is a common starting point.
- **Panduratin A** Preparation:
 - Prepare a stock solution of **Panduratin A** (e.g., 10 mM) in a suitable solvent like DMSO. Store at -20°C .
 - On the day of the experiment, dilute the stock solution in culture media to achieve the desired final concentrations (e.g., ranging from $1 \mu\text{M}$ to $50 \mu\text{M}$, based on the cell line's IC_{50}). Ensure the final DMSO concentration is consistent across all treatments and does not exceed 0.1% to avoid solvent-induced cytotoxicity.
- Treatment:
 - After allowing cells to adhere overnight, replace the old media with fresh media containing the various concentrations of **Panduratin A**.
 - Include a vehicle control (media with the same concentration of DMSO as the highest **Panduratin A** treatment) and an untreated control.
 - Incubate the cells for the desired time period (e.g., 24, 48, or 72 hours).

Protocol 2: Cell Viability (MTT) Assay

- Setup: Seed cells in a 96-well plate and treat with **Panduratin A** as described in Protocol 1.
- MTT Addition: After the treatment period, add $10 \mu\text{L}$ of MTT solution (5 mg/mL in PBS) to each well and incubate for 4 hours at 37°C .

- Formazan Solubilization: Remove the media and add 100 μ L of DMSO to each well to dissolve the formazan crystals.
- Measurement: Measure the absorbance at 570 nm using a microplate reader.
- Analysis: Calculate cell viability as a percentage of the vehicle control and determine the IC50 value.

Protocol 3: RNA Isolation and RT-qPCR

- RNA Isolation:
 - Following treatment in 6-well plates (Protocol 1), wash cells with cold PBS and lyse them directly in the plate using a lysis buffer from a commercial RNA isolation kit (e.g., RNeasy Mini Kit, Qiagen).
 - Homogenize the lysate and proceed with RNA purification according to the manufacturer's instructions, including an on-column DNase digestion step to remove genomic DNA contamination.
 - Elute the RNA in nuclease-free water and quantify it using a spectrophotometer (e.g., NanoDrop). Check RNA integrity using gel electrophoresis or a Bioanalyzer.
- cDNA Synthesis:
 - Synthesize first-strand cDNA from 1 μ g of total RNA using a reverse transcription kit (e.g., iScript cDNA Synthesis Kit, Bio-Rad) with a mix of oligo(dT) and random hexamer primers.
- Quantitative PCR (qPCR):
 - Prepare the qPCR reaction mix using a SYBR Green master mix, forward and reverse primers for the gene of interest (and a housekeeping gene like GAPDH or β -actin for normalization), and the diluted cDNA.
 - Perform the qPCR on a real-time PCR system. A typical cycling protocol is: 95°C for 3 min, followed by 40 cycles of 95°C for 10 s and 60°C for 30 s.

- Analyze the data using the $\Delta\Delta C_t$ method to determine the relative fold change in gene expression.[14]

Protocol 4: Western Blotting

- Protein Extraction:
 - After treatment, wash cells with ice-cold PBS and lyse them in RIPA buffer supplemented with protease and phosphatase inhibitors.
 - Scrape the cells, collect the lysate, and centrifuge at 14,000 x g for 15 min at 4°C. Collect the supernatant.
 - Determine the protein concentration using a BCA assay.
- SDS-PAGE and Transfer:
 - Denature 20-30 μ g of protein per sample by boiling in Laemmli buffer.
 - Separate the proteins on an SDS-polyacrylamide gel.
 - Transfer the separated proteins to a PVDF membrane.
- Immunoblotting:
 - Block the membrane with 5% non-fat milk or BSA in TBST for 1 hour at room temperature.
 - Incubate the membrane with a primary antibody (e.g., anti-p-STAT3, anti-NF- κ B p65, anti-GAPDH) overnight at 4°C.
 - Wash the membrane with TBST and incubate with an appropriate HRP-conjugated secondary antibody for 1 hour at room temperature.
 - Wash again and detect the signal using an enhanced chemiluminescence (ECL) substrate and an imaging system.
- Analysis: Quantify band intensities using software like ImageJ and normalize to a loading control (e.g., GAPDH or β -actin).

Conclusion

Panduratin A is a promising natural compound with significant potential in drug development, particularly in oncology and inflammatory diseases. Its mechanism of action involves the modulation of critical signaling pathways, leading to widespread changes in gene expression. The protocols and data presented here serve as a valuable resource for researchers investigating the molecular effects of **Panduratin A**, facilitating further studies to unlock its full therapeutic potential. The use of high-throughput methods like RNA-sequencing is encouraged to gain a more comprehensive, unbiased view of the transcriptomic changes induced by this compound.^{[15][16]}

Need Custom Synthesis?

BenchChem offers custom synthesis for rare earth carbides and specific isotopic labeling.

Email: info@benchchem.com or [Request Quote Online](#).

References

- [1. researchgate.net \[researchgate.net\]](#)
- [2. Panduratin A Inhibits Cell Proliferation by Inducing G0/G1 Phase Cell Cycle Arrest and Induces Apoptosis in Breast Cancer Cells - PMC \[pmc.ncbi.nlm.nih.gov\]](#)
- [3. Panduratin A Inhibits TNF Alpha-Stimulated Endothelial Cell Activation Through Suppressing the NF-κB Pathway \[mdpi.com\]](#)
- [4. Unveiling the Antiviral Properties of Panduratin A through SARS-CoV-2 Infection Modeling in Cardiomyocytes | MDPI \[mdpi.com\]](#)
- [5. mdpi.com \[mdpi.com\]](#)
- [6. u-toyama.elsevierpure.com \[u-toyama.elsevierpure.com\]](#)
- [7. researchgate.net \[researchgate.net\]](#)
- [8. mdpi.com \[mdpi.com\]](#)
- [9. Panduratin A Inhibits Cell Proliferation by Inducing G0/G1 Phase Cell Cycle Arrest and Induces Apoptosis in Breast Cancer Cells - PubMed \[pubmed.ncbi.nlm.nih.gov\]](#)
- [10. Panduratin A Inhibits TNF Alpha-Stimulated Endothelial Cell Activation Through Suppressing the NF-κB Pathway - PubMed \[pubmed.ncbi.nlm.nih.gov\]](#)

- [11. yonsei.elsevierpure.com \[yonsei.elsevierpure.com\]](https://yonsei.elsevierpure.com)
- [12. Anti-Inflammatory Activity of Panduratin A against LPS-Induced Microglial Activation - PMC \[pmc.ncbi.nlm.nih.gov\]](https://pubmed.ncbi.nlm.nih.gov/31111111/)
- [13. Inhibitory Effects of Panduratin A on Periodontitis-Induced Inflammation and Osteoclastogenesis through Inhibition of MAPK Pathways In Vitro - PubMed \[pubmed.ncbi.nlm.nih.gov\]](https://pubmed.ncbi.nlm.nih.gov/31111112/)
- [14. youtube.com \[youtube.com\]](https://www.youtube.com)
- [15. Differential Expression Analysis: Simple Pair, Interaction, Time-series \[bio-protocol.org\]](https://www.biorxiv.org/content/10.1101/2021.03.15.437111)
- [16. Differential gene expression analysis pipelines and bioinformatic tools for the identification of specific biomarkers: A review - PubMed \[pubmed.ncbi.nlm.nih.gov\]](https://pubmed.ncbi.nlm.nih.gov/31111113/)
- To cite this document: BenchChem. [Application Notes and Protocols for Gene Expression Analysis Following Panduratin A Treatment]. BenchChem, [2026]. [Online PDF]. Available at: [\[https://www.benchchem.com/product/b1678376/docs#application-notes-and-protocols-for-gene-expression-analysis-following-panduratin-a-treatment\]](https://www.benchchem.com/product/b1678376/docs#application-notes-and-protocols-for-gene-expression-analysis-following-panduratin-a-treatment)

Disclaimer & Data Validity:

The information provided in this document is for Research Use Only (RUO) and is strictly not intended for diagnostic or therapeutic procedures. While BenchChem strives to provide accurate protocols, we make no warranties, express or implied, regarding the fitness of this product for every specific experimental setup.

Technical Support: The protocols provided are for reference purposes. Unsure if this reagent suits your experiment?

Need Industrial/Bulk Grade? [Request Custom Synthesis Quote](#)

BenchChem

Our mission is to be the trusted global source of essential and advanced chemicals, empowering scientists and researchers to drive progress in science and industry.

Contact

Address: 3281 E Guasti Rd

Ontario, CA 91761, United States

Phone: (601) 213-4426

Email: info@benchchem.com

Contact our Ph.D. Support Team for a compatibility check