

# Application Notes and Protocols: Assessing Use-Dependent Block of (rel)-RSD 921

**Author:** BenchChem Technical Support Team. **Date:** March 2026

## Compound of Interest

Compound Name: (rel)-RSD 921

CAS No.: 111728-01-9

Cat. No.: B1678590

[Get Quote](#)

For Researchers, Scientists, and Drug Development Professionals

## Introduction

**(rel)-RSD 921** is a novel compound identified as a potent voltage-gated sodium channel blocker. Its therapeutic potential as a local anesthetic and antiarrhythmic agent is linked to its state-dependent interaction with sodium channels, particularly its use-dependent blocking characteristics.[1] Use-dependent (or frequency-dependent) block is a phenomenon where the inhibitory effect of a drug increases with the frequency of channel activation.[2][3] This property is crucial for drugs targeting rapidly firing cells, such as those in epileptic foci or arrhythmic cardiac tissue.[3]

These application notes provide detailed protocols for assessing the use-dependent block of **(rel)-RSD 921** using the two-electrode voltage clamp (TEVC) technique in *Xenopus laevis* oocytes expressing various sodium channel isoforms.

## Mechanism of Use-Dependent Block: The Modulated Receptor Hypothesis

The use-dependent block of sodium channels by local anesthetics like **(rel)-RSD 921** is well explained by the Modulated Receptor Hypothesis.[4] This hypothesis posits that the affinity of the drug for its binding site on the sodium channel is dependent on the conformational state of the channel (resting, open, or inactivated).[4] Local anesthetics typically have a higher affinity for the open and inactivated states than the resting state.[4]

During repetitive stimulation, the channels cycle through these states. With each depolarization, more channels enter the open and inactivated states, providing more high-affinity binding sites for the drug. If the drug dissociates slowly from these states during the resting phase between stimuli, the block accumulates with successive pulses, leading to a more pronounced inhibition at higher stimulation frequencies.



## FULL PROTOCOL TRUNCATED

To view exact molar ratios, purification steps, and HRP optimization data, please view the interactive version.

[Unlock Full Protocol on Website](#)

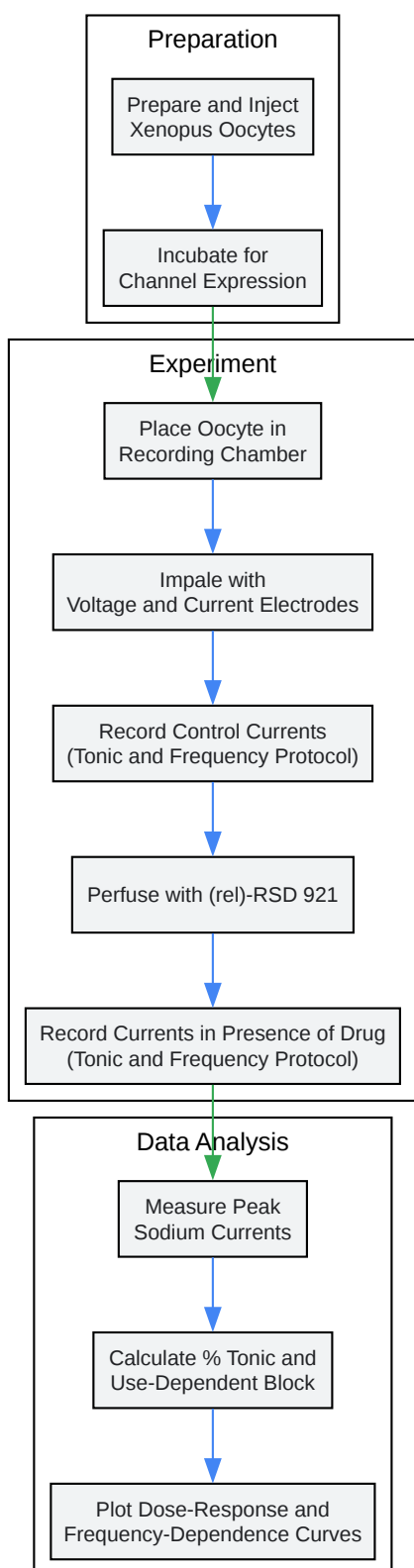

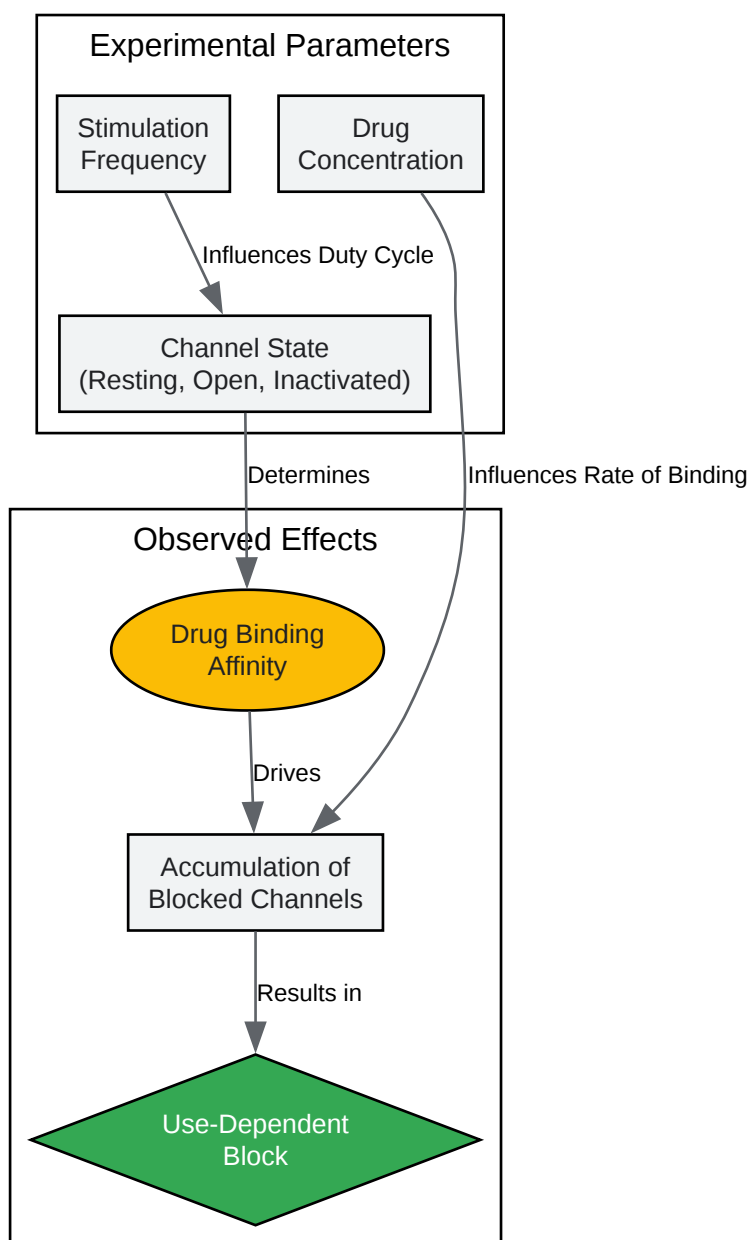

[Click to download full resolution via product page](#)

**Need Custom Synthesis?**

BenchChem offers custom synthesis for rare earth carbides and specific isotopic labeling.

Email: [info@benchchem.com](mailto:info@benchchem.com) or [Request Quote Online](#).

**References**

- [1. Pharmacological and toxicological activity of RSD921, a novel sodium channel blocker - PubMed \[pubmed.ncbi.nlm.nih.gov\]](#)
- [2. Mechanisms of use-dependent block of sodium channels in excitable membranes by local anesthetics - PubMed \[pubmed.ncbi.nlm.nih.gov\]](#)
- [3. Quantification of state-dependent drug interactions with the sodium channel - PMC \[pmc.ncbi.nlm.nih.gov\]](#)
- [4. State-Dependent Inhibition of Sodium Channels by Local Anesthetics: A 40-Year Evolution - PMC \[pmc.ncbi.nlm.nih.gov\]](#)
- To cite this document: BenchChem. [Application Notes and Protocols: Assessing Use-Dependent Block of (rel)-RSD 921]. BenchChem, [2026]. [Online PDF]. Available at: [<https://www.benchchem.com/product/b1678590#techniques-for-assessing-use-dependent-block-of-rel-rsd-921>]

---

#### Disclaimer & Data Validity:

The information provided in this document is for Research Use Only (RUO) and is strictly not intended for diagnostic or therapeutic procedures. While BenchChem strives to provide accurate protocols, we make no warranties, express or implied, regarding the fitness of this product for every specific experimental setup.

**Technical Support:** The protocols provided are for reference purposes. Unsure if this reagent suits your experiment?

**Need Industrial/Bulk Grade?** [Request Custom Synthesis Quote](#)

## BenchChem

Our mission is to be the trusted global source of essential and advanced chemicals, empowering scientists and researchers to drive progress in science and industry.

#### Contact

Address: 3281 E Guasti Rd  
Ontario, CA 91761, United States  
Phone: (601) 213-4426  
Email: [info@benchchem.com](mailto:info@benchchem.com)

Contact our Ph.D. Support Team for a compatibility check