

Revolutionizing Nanomaterial Performance: Surface Modification with m-PEG3-OH

Author: BenchChem Technical Support Team. **Date:** December 2025

Compound of Interest

Compound Name: *m-PEG3-OH*

Cat. No.: *B1677429*

[Get Quote](#)

Application Notes and Protocols for Researchers, Scientists, and Drug Development Professionals

The surface modification of nanoparticles is a critical determinant of their in vivo and in vitro performance. Unmodified nanoparticles are often subject to rapid clearance by the immune system and can exhibit poor colloidal stability in biological media. Surface modification with polyethylene glycol (PEG), a process known as PEGylation, is a widely adopted strategy to overcome these limitations. This document provides detailed application notes and protocols for the use of **m-PEG3-OH** (methoxy-terminated tri(ethylene glycol)), a short-chain PEG derivative, for the surface modification of various nanoparticles.

The use of a discrete, short-chain PEG like **m-PEG3-OH** offers precise control over the nanoparticle's surface chemistry, enhancing stability and biocompatibility. The hydrophilic nature of the PEG chain creates a "stealth" layer that reduces protein adsorption (opsonization), thereby minimizing recognition by the reticuloendothelial system and prolonging circulation time.^[1]

Key Applications of m-PEG3-OH Surface Modification:

- **Enhanced Stability:** Prevents nanoparticle aggregation in high ionic strength solutions and biological fluids.^[1]

- Improved Biocompatibility: Reduces immunogenicity and cytotoxicity of the core nanoparticle material.[2]
- Prolonged Circulation: The "stealth" effect of the PEG layer leads to longer in vivo half-lives, crucial for drug delivery applications.[1]
- Platform for Bioconjugation: While **m-PEG3-OH** itself provides a relatively inert surface, the PEG chain can be synthesized with other terminal functional groups to enable the conjugation of targeting ligands, drugs, or imaging agents.

Experimental Protocols

Protocol 1: Surface Modification of Gold Nanoparticles (AuNPs) with m-PEG3-SH

This protocol details the ligand exchange reaction to replace the citrate capping agent on gold nanoparticles with m-PEG3-SH, a thiol-terminated version of **m-PEG3-OH**, forming a stable gold-sulfur bond.

Materials:

- Citrate-capped gold nanoparticles (AuNPs)
- m-PEG3-SH (methoxy(triethylene glycol) thiol)
- Nuclease-free water
- Phosphate-buffered saline (PBS), pH 7.4
- Centrifuge
- Sonicator

Procedure:

- Prepare m-PEG3-SH Solution: Dissolve m-PEG3-SH in nuclease-free water to a final concentration of 1 mM. It is recommended to prepare this solution fresh to avoid oxidation of the thiol group.[3]

- Incubation: To the AuNP solution, add the m-PEG3-SH solution to achieve a significant molar excess (e.g., 10,000-fold molar excess of m-PEG3-SH to AuNPs).[3]
- Reaction: Gently mix the solution and incubate at room temperature for at least 24 hours with gentle stirring. This allows for the complete displacement of the citrate ions by the thiol-terminated PEG.[3]
- Purification: a. Centrifuge the solution to pellet the functionalized AuNPs. The centrifugation speed and duration will depend on the size of the AuNPs.[3] b. Carefully remove the supernatant containing excess m-PEG3-SH.[1] c. Resuspend the pellet in PBS. Sonication may be required for complete redispersion.[1] d. Repeat the centrifugation and washing steps at least three times to ensure the removal of any unbound linker.[3]
- Final Resuspension: Resuspend the final purified m-PEG3-SH-AuNPs in PBS or another desired buffer for storage at 4°C.[3]

Protocol 2: Surface Modification of Carboxylated Nanoparticles with m-PEG3-NH₂ via EDC/NHS Chemistry

This protocol describes the covalent conjugation of an amine-terminated m-PEG3 derivative (m-PEG3-NH₂) to nanoparticles with surface carboxyl groups using a two-step EDC/NHS coupling reaction.

Materials:

- Carboxylated nanoparticles
- m-PEG3-NH₂ (amine-terminated methoxy(triethylene glycol))
- N-(3-Dimethylaminopropyl)-N'-ethylcarbodiimide hydrochloride (EDC)
- N-hydroxysulfosuccinimide (sulfo-NHS)
- Activation Buffer: 50 mM MES (2-(N-morpholino)ethanesulfonic acid), pH 6.0
- Coupling Buffer: Phosphate-buffered saline (PBS), pH 7.2-8.5

- Quenching Solution: 1 M Ethanolamine or 100 mM Glycine in Coupling Buffer
- Washing Buffer: PBS with 0.05% Tween-20
- Centrifuge or magnetic separator

Procedure:

- Nanoparticle Preparation: a. Disperse the carboxylated nanoparticles in the Activation Buffer. b. Pellet the nanoparticles by centrifugation and discard the supernatant. c. Resuspend the nanoparticles in fresh Activation Buffer. Repeat this washing step twice.
- Activation of Carboxyl Groups: a. Prepare fresh solutions of EDC and sulfo-NHS in the Activation Buffer immediately before use. b. Add the EDC and sulfo-NHS solutions to the nanoparticle suspension. For recommended molar ratios, refer to Table 2. c. Incubate the mixture for 15-30 minutes at room temperature with gentle mixing.[4]
- Washing: Remove excess EDC and sulfo-NHS by washing the nanoparticles 2-3 times with Coupling Buffer.[5]
- Conjugation with m-PEG3-NH₂: a. Dissolve m-PEG3-NH₂ in the Coupling Buffer. b. Add the m-PEG3-NH₂ solution to the activated nanoparticle suspension. c. Incubate the mixture for 2-4 hours at room temperature or overnight at 4°C with gentle mixing.[5]
- Blocking Unreacted Sites: a. Wash the nanoparticles with Coupling Buffer. b. To block any remaining active NHS-ester sites, incubate the nanoparticles with the Quenching Solution for 30 minutes.[5]
- Final Washes and Resuspension: a. Wash the nanoparticles thoroughly with the Washing Buffer to remove non-covalently bound molecules.[5] b. Resuspend the purified PEGylated nanoparticles in the desired buffer for storage.

Data Presentation

Successful surface modification with m-PEG3 derivatives results in predictable changes in the physicochemical properties of the nanoparticles. The following tables summarize key quantitative data for characterization and reaction optimization.

Table 1: Physicochemical Characterization of Nanoparticles Before and After m-PEG3 Surface Modification

Parameter	Before Modification (Typical Values)	After m-PEG3 Modification (Typical Values)	Characterization Technique
Hydrodynamic Diameter	Varies (e.g., 100 nm)	Increase of 5-20 nm	Dynamic Light Scattering (DLS)
Polydispersity Index (PDI)	< 0.2	Maintained or slightly increased	Dynamic Light Scattering (DLS)
Zeta Potential	Highly negative or positive	Shift towards neutral (e.g., -5 to -15 mV)	Electrophoretic Light Scattering
Colloidal Stability in PBS	Prone to aggregation	Stable for extended periods	DLS, Visual Inspection

Table 2: Recommended Molar Ratios for EDC/NHS Coupling of m-PEG3-NH2 to Carboxylated Nanoparticles

Reagent	Molar Ratio (relative to Carboxyl Groups)	Purpose
EDC	2-10 fold excess	Activates carboxyl groups to form a reactive intermediate.
Sulfo-NHS	2-5 fold excess	Stabilizes the reactive intermediate, improving coupling efficiency.
m-PEG3-NH2	10-50 fold excess	Drives the reaction towards efficient surface coverage.

 Table 3: ¹H NMR Characterization of m-PEG3-SH

This table provides characteristic proton NMR chemical shifts for m-PEG3-SH, which can be used for quality control and to confirm the structure of the PEGylating agent.[\[6\]](#)

Functional Group	Proton Assignment	Chemical Shift (δ) in D ₂ O (ppm)
Methoxy	-O-CH ₃	~3.3
PEG Backbone	-O-CH ₂ -CH ₂ -O-	~3.5 - 3.7
Thiol-adjacent Methylene	-CH ₂ -SH	~2.7

Note: Chemical shifts can vary slightly depending on the solvent, concentration, and temperature.[6]

Visualizations

The following diagrams illustrate the experimental workflows and the chemical principles underlying the surface modification processes.

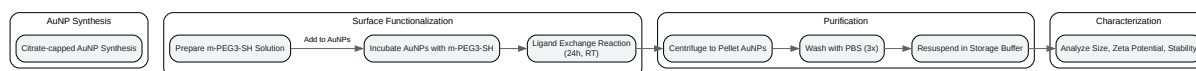

[Click to download full resolution via product page](#)

Caption: Workflow for m-PEG3-SH functionalization of gold nanoparticles.

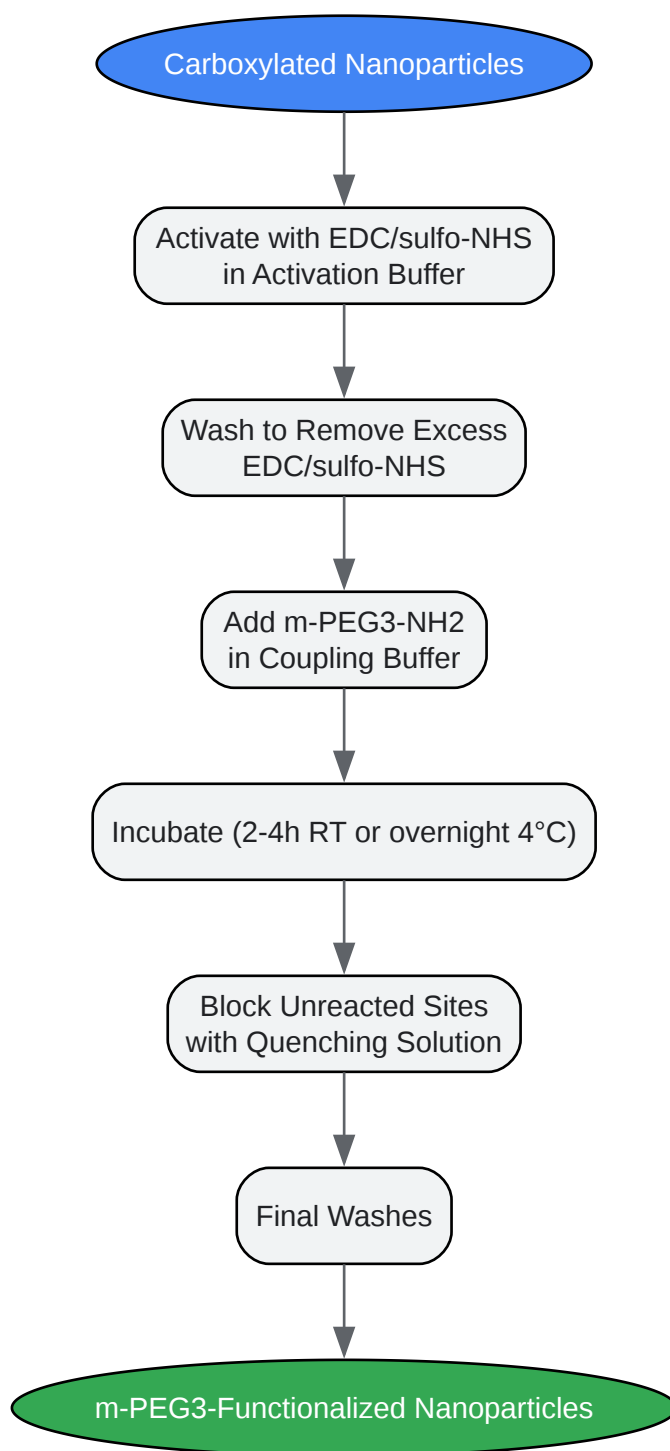

[Click to download full resolution via product page](#)

Caption: Workflow for EDC/NHS-mediated conjugation of m-PEG3-NH2.

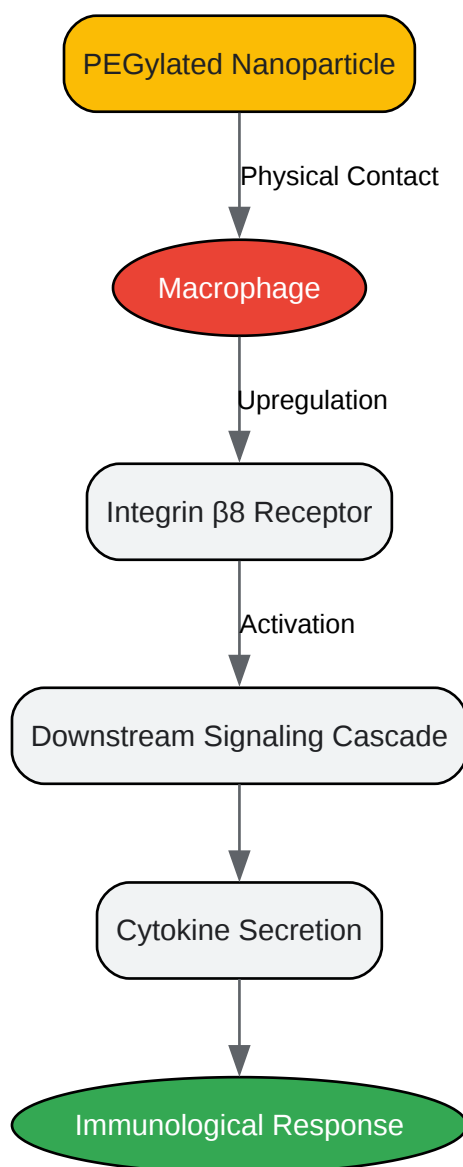

[Click to download full resolution via product page](#)

Caption: Simplified signaling pathway of macrophage activation by PEGylated nanoparticles.

Need Custom Synthesis?

BenchChem offers custom synthesis for rare earth carbides and specific isotopic labeling.

Email: info@benchchem.com or [Request Quote Online](#).

References

- 1. [benchchem.com](#) [[benchchem.com](#)]
- 2. [benchchem.com](#) [[benchchem.com](#)]
- 3. [benchchem.com](#) [[benchchem.com](#)]
- 4. General Protocol for Coupling Biomolecules to Carboxylate Particles using EDC/Sulfo-NHS [[echobiosystems.com](#)]
- 5. [benchchem.com](#) [[benchchem.com](#)]
- 6. [benchchem.com](#) [[benchchem.com](#)]
- To cite this document: BenchChem. [Revolutionizing Nanomaterial Performance: Surface Modification with m-PEG3-OH]. BenchChem, [2025]. [Online PDF]. Available at: [<https://www.benchchem.com/product/b1677429#using-m-peg3-oh-for-surface-modification-of-nanoparticles>]

Disclaimer & Data Validity:

The information provided in this document is for Research Use Only (RUO) and is strictly not intended for diagnostic or therapeutic procedures. While BenchChem strives to provide accurate protocols, we make no warranties, express or implied, regarding the fitness of this product for every specific experimental setup.

Technical Support: The protocols provided are for reference purposes. Unsure if this reagent suits your experiment? [[Contact our Ph.D. Support Team for a compatibility check](#)]

Need Industrial/Bulk Grade? [Request Custom Synthesis Quote](#)

BenchChem

Our mission is to be the trusted global source of essential and advanced chemicals, empowering scientists and researchers to drive progress in science and industry.

Contact

Address: 3281 E Guasti Rd

Ontario, CA 91761, United States

Phone: (601) 213-4426

Email: info@benchchem.com