

# Pifithrin- $\alpha$ : A Specific Inhibitor of p53 Transcriptional Activity? A Comparative Analysis

**Author:** BenchChem Technical Support Team. **Date:** April 2026

## Compound of Interest

Compound Name:	Pifithrin-
CAS No.:	64984-31-2
Cat. No.:	B1677869

[Get Quote](#)

For researchers, scientists, and drug development professionals, understanding the specificity of molecular probes is paramount. **Pifithrin- $\alpha$**  (PFT $\alpha$ ) has been widely utilized as an inhibitor of the tumor suppressor protein p53's transcriptional activity. However, accumulating evidence suggests that its mechanism of action is more complex than initially understood, with significant p53-independent effects. This guide provides a comprehensive comparison of **Pifithrin- $\alpha$**  with other p53 pathway inhibitors, supported by experimental data and detailed methodologies, to aid in the selection of the most appropriate tool for research.

## Is Pifithrin- $\alpha$ a Specific p53 Inhibitor?

**Pifithrin- $\alpha$**  acts by reversibly inhibiting p53-mediated transactivation of its target genes, thereby protecting cells from p53-dependent apoptosis and cell cycle arrest induced by genotoxic stress.[1][2] However, its reputation as a specific p53 inhibitor has been challenged. Multiple studies have revealed that **Pifithrin- $\alpha$**  exhibits off-target activities, the most prominent being its potent agonism of the Aryl Hydrocarbon Receptor (AhR).[3][4] This interaction can lead to the activation of AhR target genes, such as CYP1A1, independently of p53.[3][4] Furthermore, some studies have reported that **Pifithrin- $\alpha$**  can also suppress heat shock and glucocorticoid receptor signaling.[5] This lack of specificity raises concerns about the interpretation of data

generated using **Pifithrin- $\alpha$**  as a sole tool to probe p53 function. Researchers should exercise caution and employ complementary approaches to validate findings attributed to p53 inhibition by **Pifithrin- $\alpha$** .[\[6\]](#)

## Comparison with Alternative p53 Pathway Inhibitors

To provide a clearer perspective on **Pifithrin- $\alpha$** 's performance, this guide compares it with other well-characterized inhibitors of the p53 pathway: **Pifithrin- $\mu$** , Nutlin-3, and Roscovitine. Each of these molecules targets the p53 pathway through distinct mechanisms, offering alternative strategies for its modulation.

Inhibitor	Primary Target & Mechanism	Reported IC50/EC50	Key Off-Target Effects
Pifithrin- $\alpha$	p53 transcriptional activity	Varies by cell line and conditions (often used at 10-30 $\mu$ M)	Potent Aryl Hydrocarbon Receptor (AhR) agonist (EC50 ~13 nM for AhR-dependent gene expression); inhibits heat shock and glucocorticoid receptor signaling. <a href="#">[3]</a> <a href="#">[4]</a> <a href="#">[5]</a> <a href="#">[7]</a>
Pifithrin- $\mu$	p53 mitochondrial localization	Not explicitly defined; used at concentrations around 5-10 $\mu$ M	May inhibit Heat Shock Protein 70 (HSP70). <a href="#">[8]</a> <a href="#">[9]</a>
Nutlin-3	MDM2-p53 interaction	~90 nM for MDM2 binding <a href="#">[10]</a> <a href="#">[11]</a>	Can affect MDM2 interactions with other proteins like p73 and E2F1. <a href="#">[10]</a>
Roscovitine	Cyclin-dependent kinases (CDKs)	CDK1/cyclin B: ~0.65 $\mu$ M, CDK2/cyclin A: ~0.7 $\mu$ M, CDK5/p25: ~0.16 $\mu$ M. <a href="#">[1]</a> <a href="#">[3]</a>	Broad-spectrum kinase inhibitor; can inhibit RNA synthesis. <a href="#">[1]</a> <a href="#">[12]</a>

## Experimental Protocols

### p53 Transcriptional Activity Assay (Dual-Luciferase Reporter Assay)

This assay is a common method to quantify the effect of inhibitors on p53's ability to activate gene expression.

**Principle:** A reporter plasmid containing a p53-responsive element (p53RE) upstream of a luciferase gene is introduced into cells. A second plasmid with a constitutively expressed Renilla luciferase is co-transfected as an internal control for transfection efficiency and cell viability. Activation of p53 leads to the expression of firefly luciferase, and the resulting luminescence is measured. The ratio of firefly to Renilla luciferase activity indicates the level of p53 transcriptional activity.

Protocol Outline:

- **Cell Culture and Transfection:** Plate cells (e.g., HCT116 or U2OS) in a 96-well plate. Co-transfect with the p53-responsive firefly luciferase reporter plasmid (e.g., pGL4.38[luc2P/p53 RE/Hygro]) and a Renilla luciferase control plasmid at a ratio of approximately 10:1.[\[13\]](#)[\[14\]](#)
- **Compound Treatment:** After 24 hours, treat the cells with varying concentrations of the inhibitor (e.g., **Pifithrin- $\alpha$** ) and a p53-activating agent (e.g., doxorubicin or Nutlin-3).
- **Lysis and Luminescence Measurement:** After an appropriate incubation period (e.g., 24 hours), lyse the cells and measure firefly and Renilla luciferase activities using a dual-luciferase assay system and a luminometer.
- **Data Analysis:** Normalize the firefly luciferase signal to the Renilla luciferase signal for each well. Compare the normalized luciferase activity in inhibitor-treated wells to that of the vehicle-treated control to determine the extent of inhibition.

### p53 Mitochondrial Localization Assay (Subcellular Fractionation and Western Blotting)

This method is used to determine if an inhibitor, such as **Pifithrin- $\mu$** , prevents the translocation of p53 to the mitochondria.

Principle: Cells are treated with a stimulus to induce p53 mitochondrial translocation and the inhibitor of interest. The cells are then fractionated to separate the mitochondrial component from the rest of the cellular contents. The presence of p53 in the mitochondrial fraction is then detected by Western blotting.

Protocol Outline:

- Cell Treatment: Treat cells with a p53-activating stimulus (e.g., a DNA-damaging agent) in the presence or absence of the inhibitor (e.g., **Pifithrin- $\mu$** ).
- Cell Homogenization: Harvest the cells and resuspend them in a hypotonic buffer to induce swelling. Homogenize the cells to disrupt the plasma membrane while keeping the organelles intact.
- Subcellular Fractionation:
  - Centrifuge the homogenate at a low speed to pellet the nuclei.
  - Transfer the supernatant to a new tube and centrifuge at a higher speed to pellet the mitochondria.
- Western Blotting:
  - Lyse the mitochondrial pellet and measure the protein concentration.
  - Separate the proteins by SDS-PAGE and transfer them to a membrane.
  - Probe the membrane with antibodies against p53 and a mitochondrial marker (e.g., COX IV or VDAC) to confirm the purity of the mitochondrial fraction.
  - Detect the antibody binding using a suitable secondary antibody and imaging system.
- Data Analysis: Compare the amount of p53 in the mitochondrial fraction of inhibitor-treated cells to that of untreated cells.

## Visualizing the Mechanisms of Action

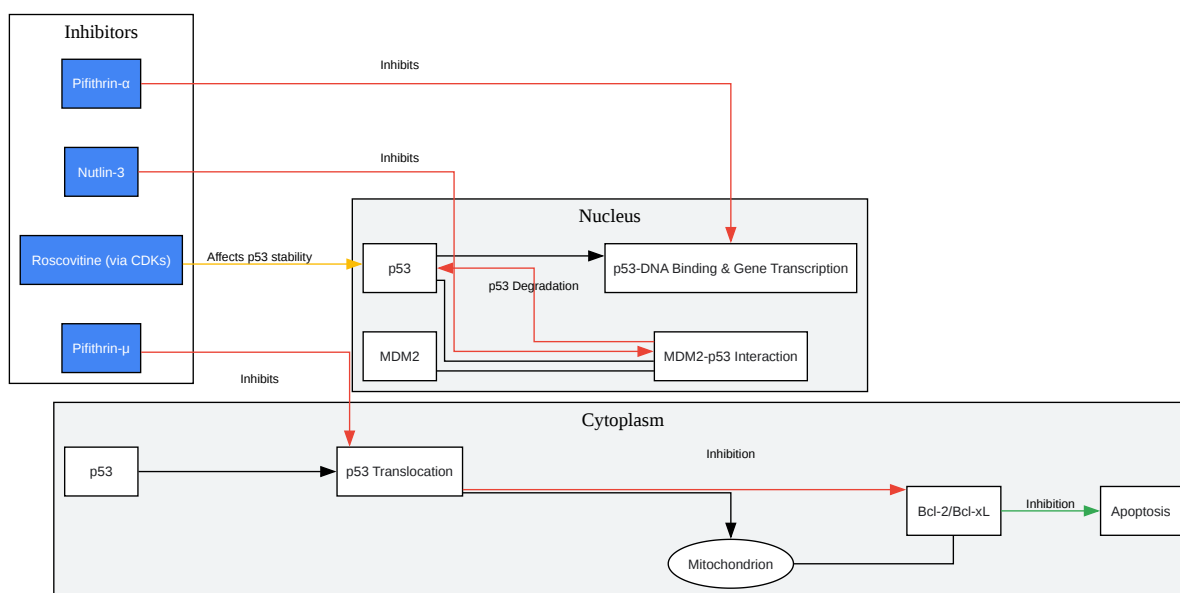

[Click to download full resolution via product page](#)

Caption: Mechanisms of action for various p53 pathway inhibitors.

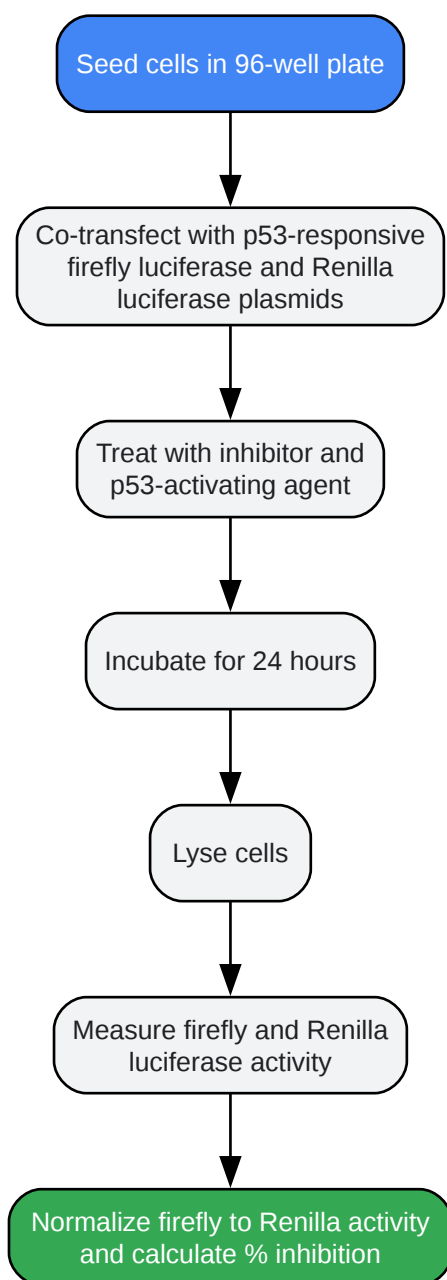

[Click to download full resolution via product page](#)

### ***Need Custom Synthesis?***

*BenchChem offers custom synthesis for rare earth carbides and specific isotopic labeling.*

*Email: [info@benchchem.com](mailto:info@benchchem.com) or [Request Quote Online](#).*

## References

- 1. Roscovitine in cancer and other diseases - PMC [pmc.ncbi.nlm.nih.gov]
- 2. The p53 inactivators pifithrin- $\mu$  and pifithrin- $\alpha$  mitigate TBI-induced neuronal damage through regulation of oxidative stress, neuroinflammation, autophagy and mitophagy - PMC [pmc.ncbi.nlm.nih.gov]
- 3. selleckchem.com [selleckchem.com]
- 4. The p53 inhibitor pifithrin-alpha is a potent agonist of the aryl hydrocarbon receptor - PubMed [pubmed.ncbi.nlm.nih.gov]
- 5. selleckchem.com [selleckchem.com]
- 6. aacrjournals.org [aacrjournals.org]
- 7. medchemexpress.com [medchemexpress.com]
- 8. p53 and Mitochondrial Function in Neurons - PMC [pmc.ncbi.nlm.nih.gov]
- 9. Pifithrin-mu | p53 | Tocris Bioscience [tocris.com]
- 10. Pharmacologic activation of p53 by small-molecule MDM2 antagonists - PMC [pmc.ncbi.nlm.nih.gov]
- 11. Inhibition of MDM2 via Nutlin-3A: A Potential Therapeutic Approach for Pleural Mesotheliomas with MDM2-Induced Inactivation of Wild-Type P53 - PMC [pmc.ncbi.nlm.nih.gov]
- 12. The cyclin-dependent kinase inhibitor roscovitine inhibits RNA synthesis and triggers nuclear accumulation of p53 that is unmodified at Ser15 and Lys382 - PubMed [pubmed.ncbi.nlm.nih.gov]
- 13. benchchem.com [benchchem.com]
- 14. pGL4.38[luc2P/p53 RE/Hygro] Vector Protocol [promega.de]
- To cite this document: BenchChem. [Pifithrin- $\alpha$ : A Specific Inhibitor of p53 Transcriptional Activity? A Comparative Analysis]. BenchChem, [2026]. [Online PDF]. Available at: [https://www.benchchem.com/product/b1677869/docs#pifithrin-a-specific-inhibitor-of-p53-transcriptional-activity-a-comparative-analysis]

---

### Disclaimer & Data Validity:

The information provided in this document is for Research Use Only (RUO) and is strictly not intended for diagnostic or therapeutic procedures. While BenchChem strives to provide accurate protocols, we make no warranties, express or implied, regarding the fitness of this product for every specific experimental setup.

**Technical Support:** The protocols provided are for reference purposes. Unsure if this reagent suits your experiment?

**Need Industrial/Bulk Grade?** [Request Custom Synthesis Quote](#)

## BenchChem

Our mission is to be the trusted global source of essential and advanced chemicals, empowering scientists and researchers to drive progress in science and industry.

### Contact

Address: 3281 E Guasti Rd

Ontario, CA 91761, United States

Phone: (601) 213-4426

Email: [info@benchchem.com](mailto:info@benchchem.com)

[Contact our Ph.D. Support Team for a compatibility check](#)