

# Fonturacetam vs. Piracetam: A Comparative Analysis of Cognitive-Enhancing Properties

**Author:** BenchChem Technical Support Team. **Date:** December 2025

## Compound of Interest

Compound Name: *Fonturacetam*

Cat. No.: *B1677641*

[Get Quote](#)

For Researchers, Scientists, and Drug Development Professionals

This guide provides a detailed, objective comparison of **Fonturacetam** and Piracetam, two synthetic compounds of the racetam family known for their nootropic, or cognitive-enhancing, effects. This analysis is based on available experimental data to assist researchers and drug development professionals in understanding the distinct pharmacological profiles of these molecules.

## Executive Summary

**Fonturacetam**, a phenylated analog of Piracetam, is generally considered to be more potent than its parent compound. The addition of a phenyl group enhances its ability to cross the blood-brain barrier, resulting in a more pronounced and broader range of neuropharmacological effects. While both compounds are reported to modulate neurotransmitter systems and exhibit neuroprotective properties, **Fonturacetam** uniquely demonstrates significant activity as a dopamine reuptake inhibitor. Piracetam, the archetypal nootropic, primarily influences membrane fluidity and modulates AMPA and NMDA glutamate receptors. The following sections provide a detailed breakdown of their comparative pharmacology, supported by experimental data.

## Data Presentation

### Table 1: Comparative Pharmacological Profile

Parameter	Fonturacetam	Piracetam
Receptor Binding Affinity		
Dopamine Transporter (DAT)	K <sub>i</sub> : 14.8 μM ((R)-enantiomer)[1]	Not reported
Nicotinic Acetylcholine Receptor (α4β2)	IC <sub>50</sub> : 5.86 μM[2]	No significant affinity
AMPA Receptor	Positive Allosteric Modulator[3]	Weak Positive Allosteric Modulator[2]
NMDA Receptor	Modulator[4]	Modulator[5][6]
Enzyme Inhibition		
Dopamine Transporter (DAT)	IC <sub>50</sub> : 65.5 μM ((R)-enantiomer)[1]	Not reported
Other Effects	Increases density of D2 and D3 receptors[7]	Increases density of muscarinic acetylcholine, and NMDA receptors[6][8]

## Table 2: Comparative Pharmacokinetic Profile

Parameter	Fonturacetam (Oral Administration)	Piracetam (Oral Administration)
Bioavailability	~100%[9]	~100%[1][10]
Time to Peak Plasma Concentration (T <sub>max</sub> )	< 1 hour[9]	1-1.5 hours[1]
Elimination Half-Life (t <sub>1/2</sub> )	3-5 hours[9]	~5 hours[3]
Metabolism	Not metabolized[9]	Not significantly metabolized[1]
Excretion	~40% via urine, ~60% via bile and sweat[9]	80-100% via urine as unchanged drug[1]

## Mechanisms of Action and Signaling Pathways

**Fonturacetam** exerts its cognitive-enhancing effects through a multi-faceted mechanism. A primary pathway involves the inhibition of the dopamine transporter (DAT), particularly by its (R)-enantiomer, leading to increased extracellular dopamine levels.[1] This action is believed to contribute to its psychostimulant and mood-enhancing properties. Additionally, **Fonturacetam** acts as a positive allosteric modulator of AMPA receptors and interacts with nicotinic acetylcholine receptors, which are crucial for synaptic plasticity and learning.[2][3]

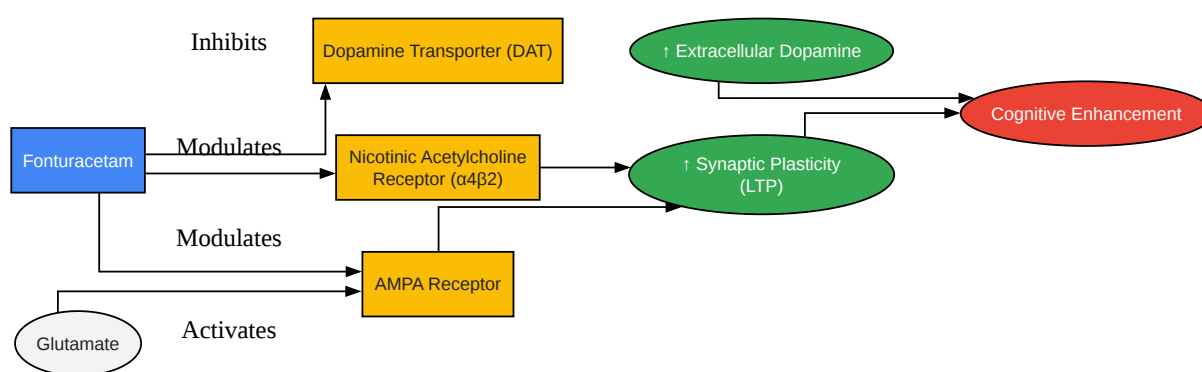

[Click to download full resolution via product page](#)

### Fonturacetam's primary signaling pathways.

Piracetam, in contrast, does not exhibit significant affinity for the dopamine transporter. Its primary mechanism is thought to involve the restoration of cell membrane fluidity, which can improve the function of membrane-bound proteins like receptors and ion channels.[6] Piracetam is a weak positive allosteric modulator of AMPA receptors and has been shown to modulate NMDA receptors, both of which are critical for long-term potentiation (LTP) and memory formation.[2][6] Furthermore, recent studies suggest that Piracetam's neuroprotective effects may be mediated through the activation of the AMPK/SIRT-1/Nrf-2 signaling pathway, which is involved in cellular stress resistance and mitochondrial biogenesis.

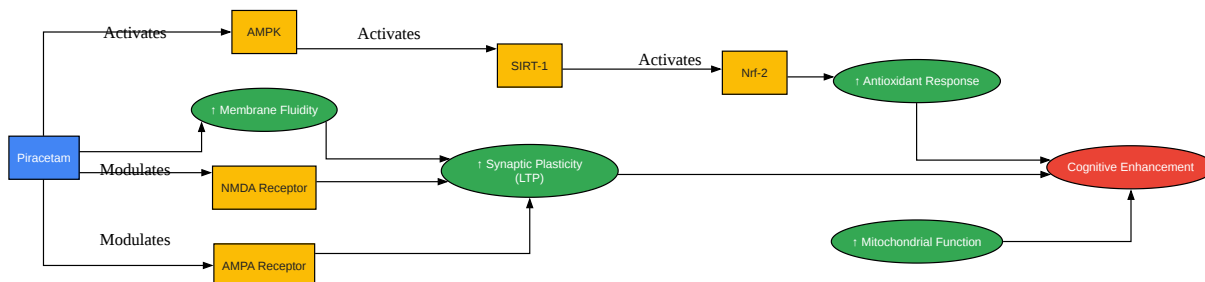

[Click to download full resolution via product page](#)

Piracetam's proposed signaling pathways.

## Experimental Protocols

### Radioligand Binding Assay for Dopamine Transporter (DAT)

This protocol provides a general framework for a competitive radioligand binding assay to determine the affinity of a test compound (e.g., **Fonturacetam**) for the dopamine transporter.

Materials:

- Membrane Preparation: Crude membrane preparations from cell lines expressing the human dopamine transporter (hDAT) or from brain tissue rich in DAT (e.g., striatum).
- Radioligand: A high-affinity radiolabeled DAT ligand, such as [<sup>3</sup>H]WIN 35,428 or [<sup>125</sup>I]RTI-121.
- Non-specific Binding Agent: A high concentration of a known DAT inhibitor (e.g., cocaine or GBR 12909) to determine non-specific binding.
- Test Compound: Serial dilutions of the compound of interest.

- Assay Buffer: Typically a Tris-HCl buffer containing various salts (e.g., NaCl, KCl, MgCl<sub>2</sub>, CaCl<sub>2</sub>).
- Filtration Apparatus: A cell harvester and glass fiber filters (pre-soaked in a solution like polyethyleneimine to reduce non-specific binding).
- Scintillation Counter and Scintillation Fluid.

#### Procedure:

- Incubation: In assay tubes, combine the membrane preparation, radioligand, and either assay buffer (for total binding), the non-specific binding agent, or a concentration of the test compound.
- Equilibration: Incubate the tubes at a specific temperature (e.g., room temperature or 4°C) for a sufficient time to allow binding to reach equilibrium.
- Filtration: Rapidly filter the contents of each tube through the glass fiber filters using the cell harvester. This separates the bound radioligand from the unbound.
- Washing: Wash the filters with ice-cold assay buffer to remove any remaining unbound radioligand.
- Counting: Place the filters in scintillation vials with scintillation fluid and measure the radioactivity using a scintillation counter.
- Data Analysis: Calculate specific binding by subtracting non-specific binding from total binding. Plot the percentage of specific binding against the log concentration of the test compound to generate a competition curve. The IC<sub>50</sub> (the concentration of the test compound that inhibits 50% of specific binding) can be determined from this curve. The K<sub>i</sub> (inhibition constant) can then be calculated using the Cheng-Prusoff equation.

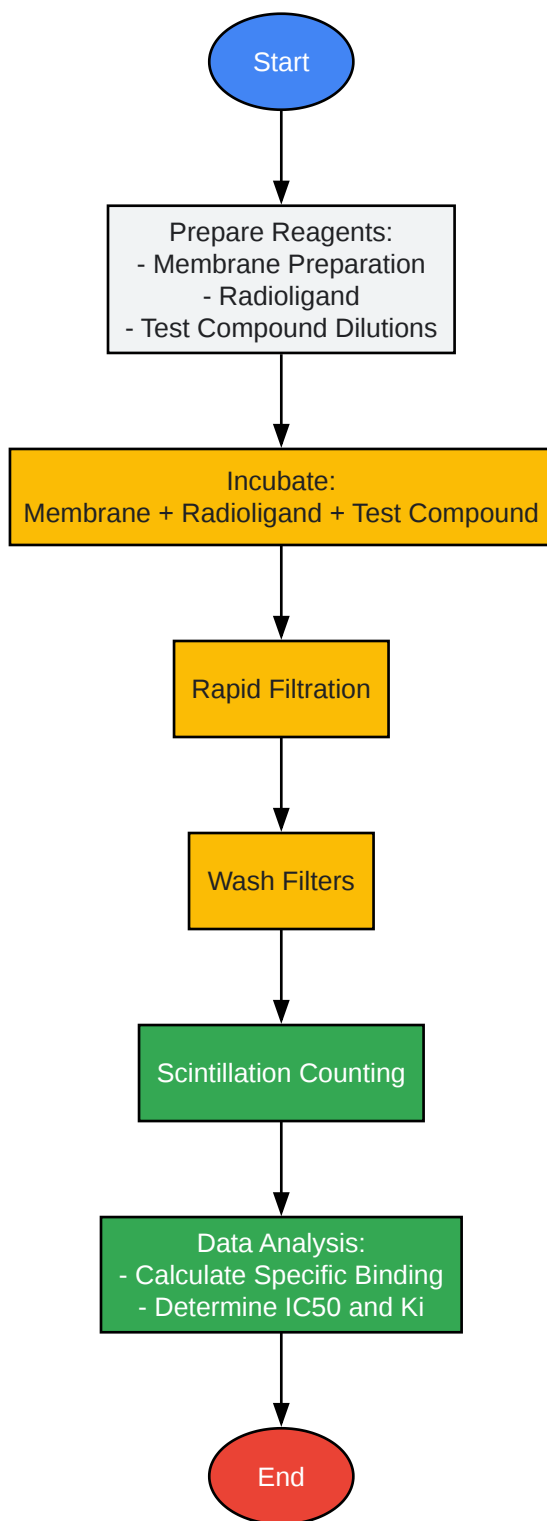

[Click to download full resolution via product page](#)

General workflow for a radioligand binding assay.

## Morris Water Maze for Cognitive Assessment

The Morris water maze is a widely used behavioral test to assess spatial learning and memory in rodents, which are relevant to the study of cognitive-enhancing drugs.

Apparatus:

- A large circular pool filled with opaque water (e.g., using non-toxic white paint or milk powder).
- An escape platform submerged just below the water's surface.
- Visual cues placed around the room, visible from the pool.
- A video tracking system to record the animal's swim path and latency to find the platform.

Procedure:

- Acquisition Phase:
  - The rodent is placed in the pool at one of several predetermined starting locations.
  - The animal swims until it finds the hidden platform. If it fails to find the platform within a set time (e.g., 60 seconds), it is gently guided to it.
  - The animal is allowed to remain on the platform for a short period (e.g., 15-30 seconds) to associate its location with the surrounding visual cues.
  - This is repeated for several trials per day over a number of consecutive days. The latency to find the platform and the swim path length are recorded. A decrease in these measures over time indicates learning.
- Probe Trial:
  - After the acquisition phase, the platform is removed from the pool.
  - The animal is allowed to swim freely for a set duration (e.g., 60 seconds).
  - The time spent in the target quadrant (where the platform was previously located) is measured. A significant preference for the target quadrant indicates spatial memory.

- Reversal Learning (Optional):
  - The platform is moved to a new location, and the acquisition and probe trials are repeated to assess cognitive flexibility.

## Conclusion

**Fonturacetam** and Piracetam, while structurally related, exhibit distinct pharmacological profiles that translate to differences in their cognitive-enhancing effects. **Fonturacetam's** activity as a dopamine reuptake inhibitor provides a clear mechanism for its reported stimulant properties, a feature not shared by Piracetam. Both compounds appear to modulate glutamatergic neurotransmission, a key process in learning and memory, although Piracetam's interaction with AMPA receptors is notably weaker. The enhanced blood-brain barrier penetration of **Fonturacetam** likely contributes to its increased potency. Further head-to-head comparative studies employing standardized experimental protocols are warranted to more definitively delineate the quantitative differences in their receptor binding affinities, pharmacokinetic profiles, and dose-dependent effects on cognitive performance. This guide serves as a foundational resource for researchers and professionals in the field of drug development, providing a structured overview of the current understanding of these two prominent nootropic agents.

### *Need Custom Synthesis?*

*BenchChem offers custom synthesis for rare earth carbides and specific isotopic labeling.*

*Email: [info@benchchem.com](mailto:info@benchchem.com) or [Request Quote Online](#).*

## References

- 1. mims.com [mims.com]
- 2. Piracetam Defines a New Binding Site for Allosteric Modulators of  $\alpha$ -amino-3-hydroxy-5-methyl-4-isoxazole-propionic acid (AMPA) receptors - PMC [pmc.ncbi.nlm.nih.gov]
- 3. assets.hpra.ie [assets.hpra.ie]
- 4. mdpi.com [mdpi.com]
- 5. Pharmacokinetics of piracetam: a study on the bioavailability with special regard to renal and non-renal elimination - PubMed [pubmed.ncbi.nlm.nih.gov]



- 6. Frontiers | Improved mitochondrial function in brain aging and Alzheimer disease - the new mechanism of action of the old metabolic enhancer piracetam [frontiersin.org]
- 7. pdspdb.unc.edu [pdspdb.unc.edu]
- 8. consensus.app [consensus.app]
- 9. Phenylpiracetam - Wikipedia [en.wikipedia.org]
- 10. Piracetam - Wikipedia [en.wikipedia.org]
- To cite this document: BenchChem. [Fonturacetam vs. Piracetam: A Comparative Analysis of Cognitive-Enhancing Properties]. BenchChem, [2025]. [Online PDF]. Available at: [https://www.benchchem.com/product/b1677641#fonturacetam-vs-piracetam-a-comparative-study-on-cognitive-enhancement]

---

### Disclaimer & Data Validity:

The information provided in this document is for Research Use Only (RUO) and is strictly not intended for diagnostic or therapeutic procedures. While BenchChem strives to provide accurate protocols, we make no warranties, express or implied, regarding the fitness of this product for every specific experimental setup.

**Technical Support:** The protocols provided are for reference purposes. Unsure if this reagent suits your experiment? [[Contact our Ph.D. Support Team for a compatibility check](#)]

**Need Industrial/Bulk Grade?** [Request Custom Synthesis Quote](#)

## BenchChem

Our mission is to be the trusted global source of essential and advanced chemicals, empowering scientists and researchers to drive progress in science and industry.

### Contact

Address: 3281 E Guasti Rd

Ontario, CA 91761, United States

Phone: (601) 213-4426

Email: [info@benchchem.com](mailto:info@benchchem.com)