

MRS2603: An In-Depth Technical Guide to its Mechanism of Action

Author: BenchChem Technical Support Team. **Date:** April 2026

Compound of Interest

Compound Name: MRS2603

Cat. No.: B1676840

[Get Quote](#)

For Researchers, Scientists, and Drug Development Professionals

Abstract

MRS2603 is a potent and selective synthetic agonist for the P2Y₁₁ purinergic receptor, a unique G protein-coupled receptor (GPCR) distinguished by its dual coupling to both stimulatory (G_s) and quinone-sensitive (G_q) G protein signaling pathways. This dual functionality allows **MRS2603** to induce a bifurcated signaling cascade, leading to the activation of adenylyl cyclase and a subsequent increase in intracellular cyclic adenosine monophosphate (cAMP), as well as the stimulation of phospholipase C, which results in inositol trisphosphate generation and the mobilization of intracellular calcium. This comprehensive guide elucidates the core mechanism of action of **MRS2603**, presenting key quantitative data, detailed experimental protocols for its characterization, and visual diagrams of its signaling pathways and experimental workflows. The anti-inflammatory properties of **MRS2603**, mediated through the cAMP-dependent arm of its signaling pathway, are also explored, highlighting its therapeutic potential.

Core Mechanism: Dual G Protein-Coupled Signaling

The P2Y₁₁ receptor, the specific molecular target of **MRS2603**, is an atypical member of the P2Y receptor family due to its ability to engage two distinct G protein subtypes.[1][2] This dual coupling is the cornerstone of **MRS2603**'s mechanism of action.

- **Gs-Coupled Pathway (Adenylyl Cyclase Activation):** Upon binding of **MRS2603**, the P2Y₁₁ receptor activates the Gs alpha subunit. This, in turn, stimulates adenylyl cyclase, an enzyme that catalyzes the conversion of ATP to cyclic AMP (cAMP).[3] The accumulation of intracellular cAMP activates protein kinase A (PKA), which then phosphorylates a multitude of downstream targets, leading to various cellular responses, including the modulation of inflammatory processes.[4]
- **Gq-Coupled Pathway (Calcium Mobilization):** Concurrently, **MRS2603**-induced activation of the P2Y₁₁ receptor also engages the Gq alpha subunit.[1] Activated Gq stimulates phospholipase C (PLC), which cleaves phosphatidylinositol 4,5-bisphosphate (PIP₂) into two second messengers: inositol 1,4,5-trisphosphate (IP₃) and diacylglycerol (DAG). IP₃ binds to its receptors on the endoplasmic reticulum, triggering the release of stored calcium ions (Ca²⁺) into the cytoplasm.[5] This transient increase in intracellular calcium concentration mediates a wide array of cellular functions.

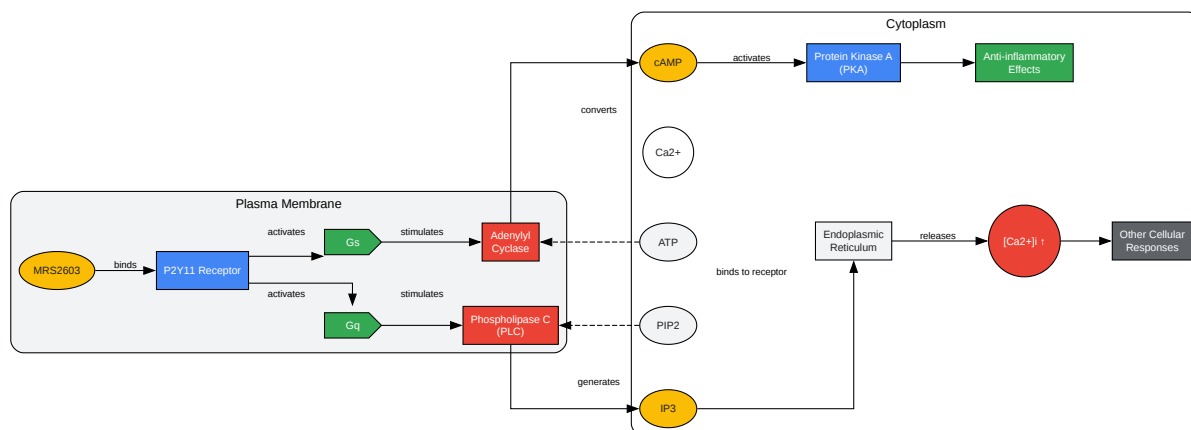

[Click to download full resolution via product page](#)

Caption: Dual signaling pathway of **MRS2603** via the P2Y11 receptor.

Quantitative Data

The potency and efficacy of **MRS2603** are typically quantified by its half-maximal effective concentration (EC50) for inducing cAMP accumulation and intracellular calcium mobilization. While specific EC50 values for **MRS2603** can vary depending on the cell type and experimental conditions, it is characterized as a potent agonist for the P2Y11 receptor. For comparative purposes, the potencies of other P2Y11 agonists are presented below.

Agonist	Signaling Pathway	Cell Type	EC50 (μM)
ATP	cAMP Accumulation	CHO-K1	17.4 ± 6.1
IP3 Production	1321N1 Astrocytoma	72 ± 8	
ATPyS	cAMP Accumulation	CHO-K1	Data not specified
IP3 Production	1321N1 Astrocytoma	Data not specified	
BzATP	cAMP Accumulation	CHO-K1	Data not specified
IP3 Production	1321N1 Astrocytoma	Data not specified	

Note: Data for ATP, ATPyS, and BzATP are derived from studies on recombinant human P2Y11 receptors and are provided for context. Specific EC50 values for **MRS2603** should be determined empirically for the system under investigation.

Anti-inflammatory Mechanism

A significant functional consequence of **MRS2603**-mediated P2Y11 activation is the suppression of pro-inflammatory responses in immune cells. This effect is primarily attributed to the Gs-cAMP-PKA arm of the signaling cascade.

In immune cells such as M2 macrophages, activation of the P2Y11 receptor leads to an increase in intracellular cAMP.[6] Elevated cAMP levels have been shown to inhibit the signaling of Toll-like receptors (TLRs), such as TLR4.[6] Specifically, P2Y11 activation can prevent the secretion of the pro-inflammatory cytokine tumor necrosis factor-alpha (TNF-α) following stimulation with lipopolysaccharide (LPS), a TLR4 ligand.[6] This targeted suppression of a key inflammatory mediator underscores the therapeutic potential of **MRS2603** in inflammatory conditions.

Experimental Protocols

The characterization of **MRS2603**'s mechanism of action involves distinct assays to quantify the activation of its dual signaling pathways.

cAMP Accumulation Assay

This assay quantifies the production of intracellular cAMP following receptor activation. A common method is the Homogeneous Time-Resolved Fluorescence (HTRF) competitive immunoassay.[7]

Principle: Endogenous cAMP produced by cells competes with a labeled cAMP analog (e.g., d2-labeled cAMP) for binding to a specific anti-cAMP antibody coupled to a fluorescent donor (e.g., Europium cryptate). The proximity of the donor and acceptor molecules results in a FRET signal that is inversely proportional to the amount of cAMP produced by the cells.

Protocol Outline:

- Cell Culture: Culture cells expressing the P2Y11 receptor (either endogenously or through transfection) in a suitable plate format (e.g., 96- or 384-well).[8]
- Cell Stimulation: Treat the cells with varying concentrations of **MRS2603** for a defined period to stimulate cAMP production. A phosphodiesterase inhibitor is often included to prevent cAMP degradation.
- Lysis and Detection: Lyse the cells and add the HTRF detection reagents (anti-cAMP-cryptate and cAMP-d2).
- Signal Measurement: After incubation, measure the HTRF signal using a compatible plate reader.
- Data Analysis: Calculate the concentration of cAMP produced based on a standard curve and determine the EC50 value for **MRS2603**.

Intracellular Calcium Mobilization Assay

This assay measures the transient increase in intracellular calcium concentration upon receptor activation. Fluorometric methods using calcium-sensitive dyes and a Fluorometric Imaging Plate Reader (FLIPR) are widely used.[9][10][11]

Principle: Cells are loaded with a fluorescent calcium indicator dye (e.g., Fluo-4 AM) that exhibits a significant increase in fluorescence intensity upon binding to Ca²⁺. The FLIPR system allows for the real-time monitoring of these fluorescence changes in a high-throughput format.

Protocol Outline:

- **Cell Plating:** Seed P2Y11-expressing cells into a microplate (e.g., 96- or 384-well) and allow them to adhere.
- **Dye Loading:** Incubate the cells with a calcium-sensitive fluorescent dye (e.g., Fluo-4 AM) in a physiological buffer. The AM ester form allows the dye to cross the cell membrane, where it is cleaved by intracellular esterases, trapping the active dye inside.
- **Assay Execution:** Place the plate in the FLIPR instrument. The instrument adds varying concentrations of **MRS2603** to the wells while simultaneously measuring the fluorescence intensity over time.
- **Data Analysis:** The change in fluorescence intensity reflects the increase in intracellular calcium. Plot the peak fluorescence response against the concentration of **MRS2603** to determine the EC50 value.

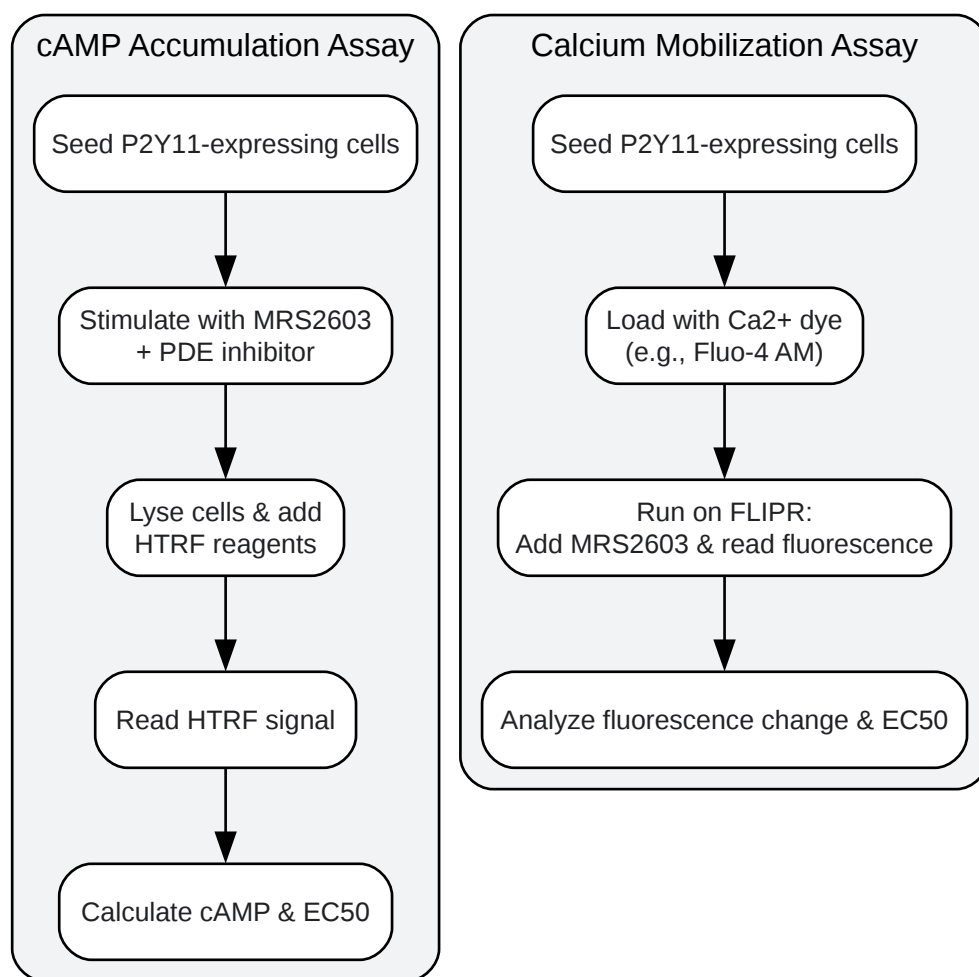

[Click to download full resolution via product page](#)

Caption: Experimental workflows for characterizing **MRS2603** activity.

Conclusion

MRS2603 exerts its biological effects through the selective activation of the P2Y11 receptor, initiating a unique dual signaling cascade involving both G_s- and G_q-coupled pathways. This leads to the concomitant accumulation of intracellular cAMP and mobilization of intracellular calcium. The cAMP-mediated arm of this signaling pathway provides a mechanism for the observed anti-inflammatory effects of **MRS2603**, particularly the suppression of TNF- α production. The quantitative characterization of these dual signaling events through robust in vitro assays is essential for the continued investigation and potential therapeutic development of **MRS2603** and other P2Y11-targeting compounds.

Need Custom Synthesis?

BenchChem offers custom synthesis for rare earth carbides and specific isotopic labeling.

Email: info@benchchem.com or [Request Quote Online](#).

References

- 1. The human G protein-coupled ATP receptor P2Y11 is a target for anti-inflammatory strategies - PMC [[pmc.ncbi.nlm.nih.gov](https://pubmed.ncbi.nlm.nih.gov)]
- 2. Coupling of P2Y receptors to G proteins and other signaling pathways - PMC [[pmc.ncbi.nlm.nih.gov](https://pubmed.ncbi.nlm.nih.gov)]
- 3. P2Y11 receptors activate adenylyl cyclase and contribute to nucleotide-promoted cAMP formation in MDCK-D(1) cells. A mechanism for nucleotide-mediated autocrine-paracrine regulation - PubMed [pubmed.ncbi.nlm.nih.gov]
- 4. Regulation of Ca²⁺ release by cAMP-dependent protein kinase. A mechanism for agonist-specific calcium signaling? - PubMed [pubmed.ncbi.nlm.nih.gov]
- 5. Extracellular NAD⁺ is an agonist of the human P2Y11 purinergic receptor in human granulocytes - PubMed [pubmed.ncbi.nlm.nih.gov]
- 6. The human G protein-coupled ATP receptor P2Y11 is a target for anti-inflammatory strategies - PubMed [pubmed.ncbi.nlm.nih.gov]
- 7. cAMP Accumulation Assay - Creative BioMart [creativebiomart.net]
- 8. revvity.com [revvity.com]
- 9. FLIPR Calcium Mobilization Assays in GPCR Drug Discovery - PubMed [pubmed.ncbi.nlm.nih.gov]
- 10. FLIPR assays of intracellular calcium in GPCR drug discovery - PubMed [pubmed.ncbi.nlm.nih.gov]
- 11. docs.aatbio.com [docs.aatbio.com]
- To cite this document: BenchChem. [MRS2603: An In-Depth Technical Guide to its Mechanism of Action]. BenchChem, [2026]. [Online PDF]. Available at: [<https://www.benchchem.com/product/b1676840/docs#mrs2603-an-in-depth-technical-guide-to-its-mechanism-of-action>]

Disclaimer & Data Validity:

The information provided in this document is for Research Use Only (RUO) and is strictly not intended for diagnostic or therapeutic procedures. While BenchChem strives to provide accurate protocols, we make no warranties, express or implied, regarding the fitness of this product for every specific experimental setup.

Technical Support: The protocols provided are for reference purposes. Unsure if this reagent suits your experiment?

Need Industrial/Bulk Grade? [Request Custom Synthesis Quote](#)

BenchChem

Our mission is to be the trusted global source of essential and advanced chemicals, empowering scientists and researchers to drive progress in science and industry.

Contact

Address: 3281 E Guasti Rd
Ontario, CA 91761, United States
Phone: (601) 213-4426
Email: info@benchchem.com

[Contact our Ph.D. Support Team for a compatibility check](#)