

ML351: A Technical Guide to its Mechanism of Action in Neuronal Cells

Author: BenchChem Technical Support Team. **Date:** April 2026

Compound of Interest

Compound Name:	ML351
CAS No.:	847163-28-4
Cat. No.:	B1676651

[Get Quote](#)

For Researchers, Scientists, and Drug Development Professionals

Abstract

ML351 is a potent and selective small-molecule inhibitor of 15-lipoxygenase-1 (15-LOX-1), also known as 12/15-lipoxygenase (12/15-LOX) in mice. In the context of neuronal cells, **ML351** exhibits significant neuroprotective properties, primarily by mitigating oxidative stress-induced cell death. This technical guide provides an in-depth analysis of the mechanism of action of **ML351** in neuronal cells, summarizing key quantitative data, detailing experimental protocols, and visualizing the implicated signaling pathways. The primary mechanism involves the inhibition of the 12/15-LOX enzyme, which in turn prevents downstream inflammatory and apoptotic cascades, including the suppression of NLRP1 and NLRP3 inflammasome activation.

Core Mechanism of Action: Inhibition of 15-Lipoxygenase-1

ML351 was identified through a quantitative high-throughput screen as a novel and potent inhibitor of human 15-LOX-1.[1][2] Its primary mode of action in neuronal cells is the direct

inhibition of this enzyme, which is implicated in various neurodegenerative conditions and ischemic stroke.[1][2][3] Under conditions of oxidative stress, such as glutamate toxicity or ischemia, 12/15-LOX is upregulated and activated in neurons.[3][4][5] This activation leads to the production of lipid hydroperoxides, which contribute to mitochondrial damage, increased reactive oxygen species (ROS) production, and subsequent neuronal cell death.[4][5] **ML351** effectively blocks this enzymatic activity, thereby conferring neuroprotection.[1][2]

Quantitative Data Summary

The following tables summarize the key quantitative findings related to the activity and efficacy of **ML351**.

Table 1: In Vitro Inhibitory Activity of **ML351**

Target	IC50	Selectivity	Source
Human 15-LOX-1	200 nM	>250-fold vs. 5-LOX, 12-LOX, 15-LOX-2, COX-1, COX-2	[1][2]

Table 2: Neuroprotective Effects of **ML351** in Neuronal Cell Models

Cell Line	Insult	Endpoint	Effective Concentration	Source
HT-22 (mouse hippocampal)	5 mM Glutamate	Increased cell viability	Not specified	[1][2]
HT-22 (mouse hippocampal)	H2O2	Increased cell viability	10, 20, 40 μM	[6]

Table 3: In Vivo Effects of **ML351** in a Mouse Model of Ischemic Stroke

Parameter	Treatment	Outcome	Source
Infarct Volume	ML351 (50 mg/kg, i.p.)	Significantly reduced at 6, 24, and 72 hours	[3]
Neurological Deficit Score	ML351 (50 mg/kg, i.p.)	Significantly attenuated at 6, 24, and 72 hours	[3]
Pro-inflammatory Cytokines (IL-1 β , IL-6, TNF- α)	ML351 (50 mg/kg, i.p.)	Significantly decreased at 6 and/or 24 hours	[3]
Anti-inflammatory Cytokines (IL-10, TGF- β)	ML351 (50 mg/kg, i.p.)	Increased at 24 and/or 72 hours	[3]
NLRP1 and NLRP3 Inflammasome Activation	ML351 (50 mg/kg, i.p.)	Significantly diminished at 6, 24, and 72 hours	[3]

Signaling Pathways

ML351 exerts its neuroprotective effects by intervening in a well-defined signaling cascade initiated by oxidative stress.

Oxidative Stress-Induced 12/15-LOX Activation and Mitochondrial Damage

Under oxidative stress conditions, such as high levels of extracellular glutamate in HT-22 cells, the intracellular antioxidant glutathione is depleted.[5] This leads to the activation of 12/15-LOX, which then targets mitochondria, causing a breakdown of the mitochondrial membrane potential, release of cytochrome c, and a surge in reactive oxygen species (ROS).[4][5]

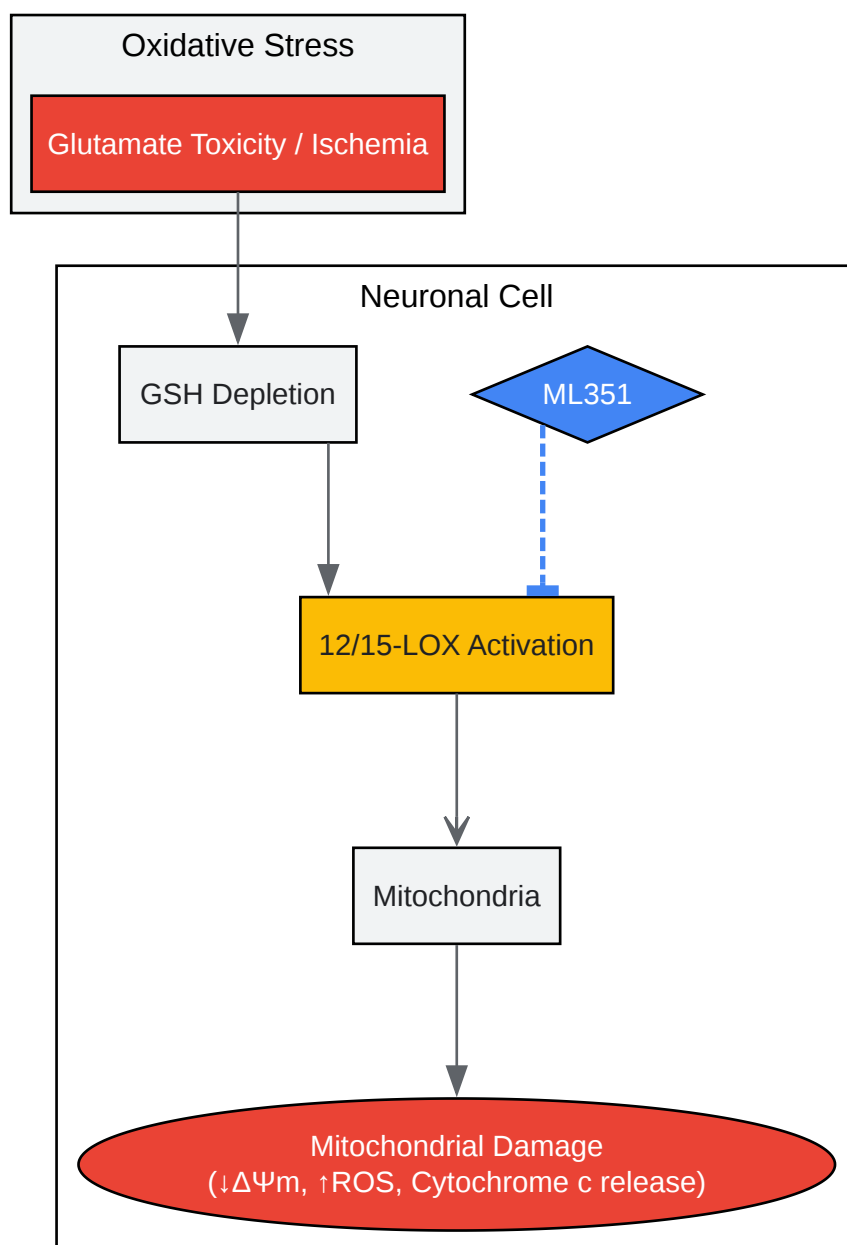

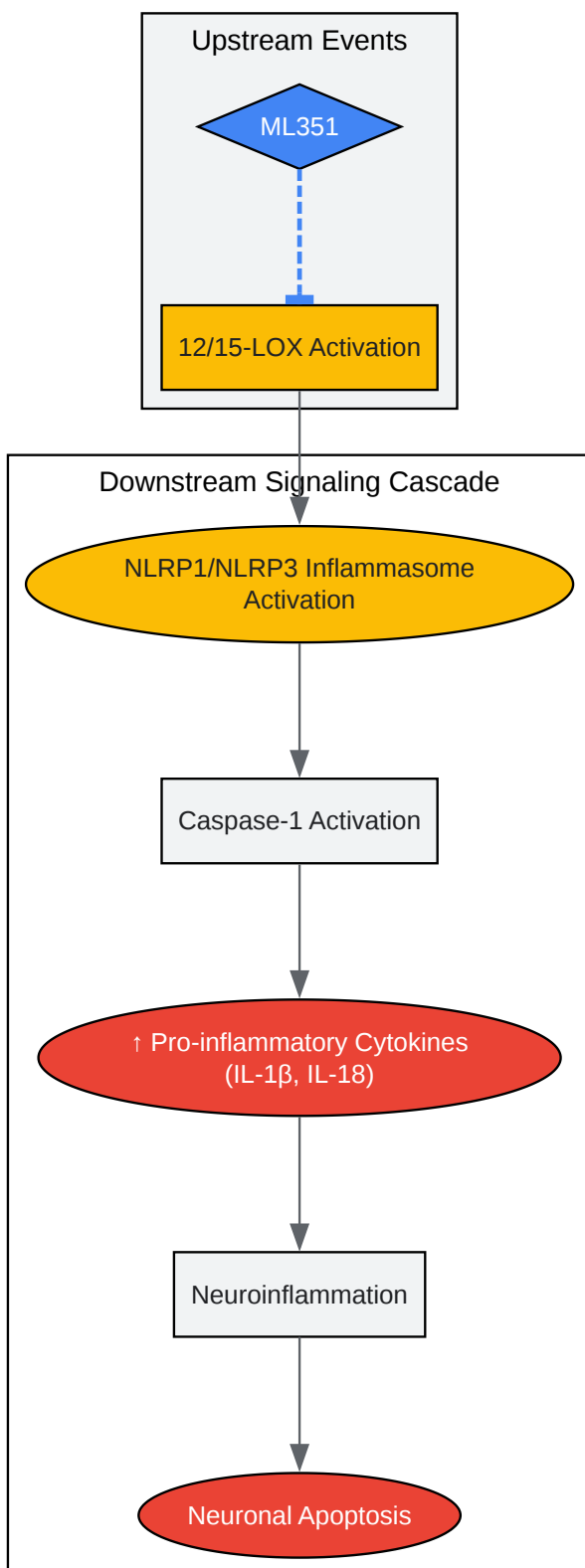

[Click to download full resolution via product page](#)

Need Custom Synthesis?

BenchChem offers custom synthesis for rare earth carbides and specific isotopic labeling.

Email: info@benchchem.com or [Request Quote Online](#).

References

- 1. Discovery of ML351, a Potent and Selective Inhibitor of Human 15-Lipoxygenase-1 - Probe Reports from the NIH Molecular Libraries Program - NCBI Bookshelf [ncbi.nlm.nih.gov]
- 2. Discovery of ML351, a Potent and Selective Inhibitor of Human 15-Lipoxygenase-1 - PubMed [pubmed.ncbi.nlm.nih.gov]
- 3. 12/15-lipoxygenase inhibition attenuates neuroinflammation by suppressing inflammasomes - PMC [pmc.ncbi.nlm.nih.gov]
- 4. 12/15-Lipoxygenase targets neuronal mitochondria under oxidative stress - PubMed [pubmed.ncbi.nlm.nih.gov]
- 5. 12/15-Lipoxygenase targets neuronal mitochondria under oxidative stress - PMC [pmc.ncbi.nlm.nih.gov]
- 6. Inhibition of 12/15-LOX hyperactivation mitigates cognitive decline in a chronic cerebral hypoperfusion mouse model and in H₂O₂-induced HT22 cells: therapeutic effects of brozopine - PMC [pmc.ncbi.nlm.nih.gov]
- To cite this document: BenchChem. [ML351: A Technical Guide to its Mechanism of Action in Neuronal Cells]. BenchChem, [2026]. [Online PDF]. Available at: [<https://www.benchchem.com/product/b1676651/docs#ml351-a-technical-guide-to-its-mechanism-of-action-in-neuronal-cells>]

Disclaimer & Data Validity:

The information provided in this document is for Research Use Only (RUO) and is strictly not intended for diagnostic or therapeutic procedures. While BenchChem strives to provide accurate protocols, we make no warranties, express or implied, regarding the fitness of this product for every specific experimental setup.

Technical Support: The protocols provided are for reference purposes. Unsure if this reagent suits your experiment?

Need Industrial/Bulk Grade? [Request Custom Synthesis Quote](#)

BenchChem

Our mission is to be the trusted global source of essential and advanced chemicals, empowering scientists and researchers to drive progress in science and industry.

Contact

Address: 3281 E Guasti Rd
Ontario, CA 91761, United States
Phone: (601) 213-4426
Email: info@benchchem.com

[Contact our Ph.D. Support Team for a compatibility check](#)