

# An In-depth Technical Guide to the Chemical Structure of Metahexamide

**Author:** BenchChem Technical Support Team. **Date:** May 2026

## Compound of Interest

Compound Name: *Metahexamide*

CAS No.: 565-33-3

Cat. No.: B1676324

[Get Quote](#)

For Researchers, Scientists, and Drug Development Professionals

## Introduction

**Metahexamide** is a first-generation sulfonylurea drug with antihyperglycemic properties.[1][2][3] Historically used in the management of type 2 diabetes mellitus, it functions by stimulating insulin release from pancreatic  $\beta$ -cells. This guide provides a detailed overview of the chemical structure of **Metahexamide**, its physicochemical properties, and the signaling pathway through which it exerts its therapeutic effect. While specific experimental data for **Metahexamide** is limited due to its status as an older drug, this document compiles available information and provides generalized experimental protocols relevant to its synthesis and characterization.

## Chemical and Physical Properties

The fundamental physicochemical properties of **Metahexamide** are summarized in the table below. This data is essential for its handling, formulation, and analysis in a research and development setting.

Property	Value	Reference
IUPAC Name	1-(3-amino-4-methylphenyl)sulfonyl-3-cyclohexylurea	[1]
Alternate IUPAC Name	3-Amino-N-(cyclohexylcarbamoyl)-4-methylbenzene-1-sulfonamide	[2]
Molecular Formula	C <sub>14</sub> H <sub>21</sub> N <sub>3</sub> O <sub>3</sub> S	[1][2]
Molar Mass	311.40 g/mol	[1]
CAS Number	565-33-3	[2]
PubChem CID	11259	[1]
SMILES	<chem>CC1=C(C=C(C=C1)S(=O)(=O)NC(=O)NC2CCCCC2)N</chem>	[1]
Stereochemistry	Achiral	[4]

## Chemical Structure Visualization

The two-dimensional chemical structure of **Metahexamide** is depicted below. The structure was generated using the DOT language and illustrates the connectivity of the atoms, including the characteristic sulfonylurea moiety linked to a substituted benzene ring and a cyclohexyl group.

**Figure 1:** Chemical structure of **Metahexamide**.

## Experimental Protocols

Detailed experimental protocols for the synthesis and characterization of **Metahexamide** are not readily available in recent literature. The following sections provide generalized methodologies for the synthesis of related sulfonylureas and standard characterization techniques that would be applicable to **Metahexamide**.

## General Synthesis of a Sulfonylurea

The synthesis of a sulfonylurea, such as **Metahexamide**, typically involves a multi-step process. A plausible, though generalized, synthetic route is outlined below.

#### Workflow for Generalized Sulfonylurea Synthesis

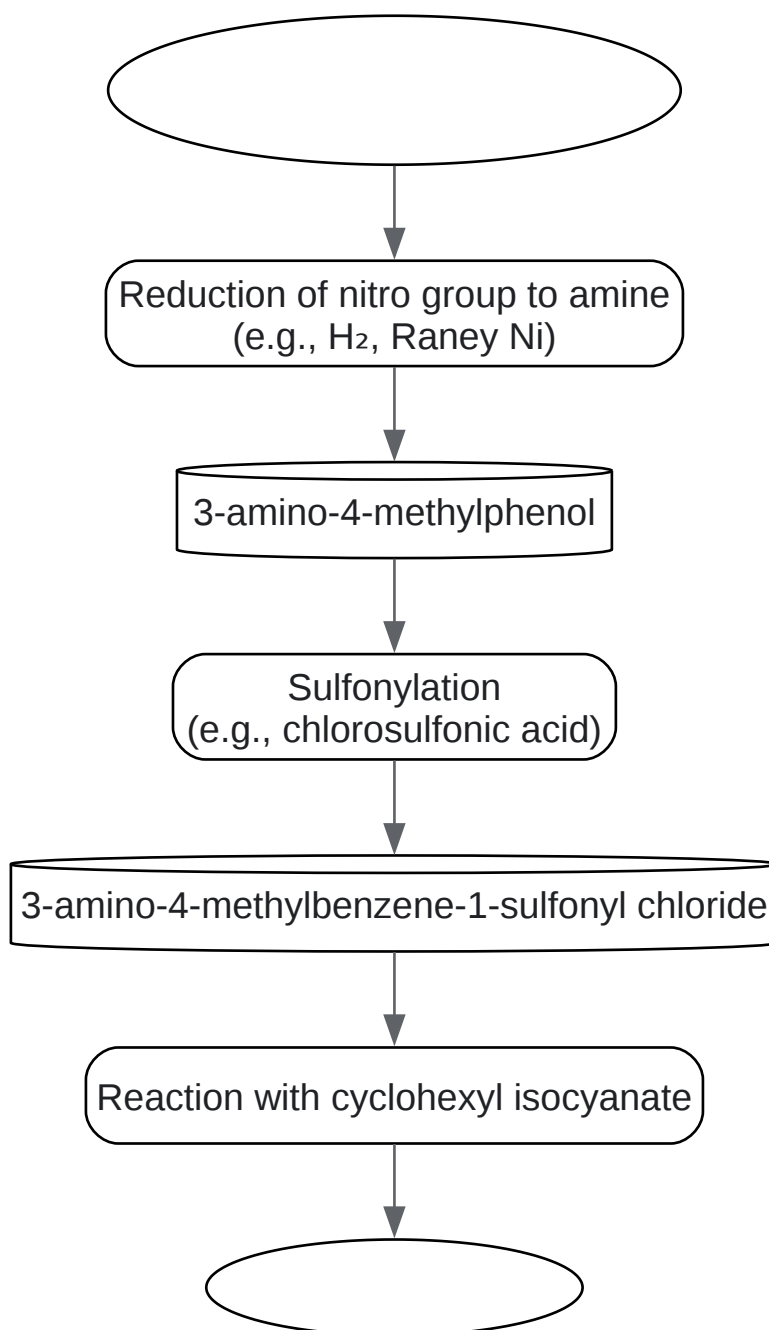

[Click to download full resolution via product page](#)

**Figure 2:** A generalized synthetic workflow for **Metahexamide**.

#### Methodology:

- **Reduction of the Nitro Group:** The starting material, 3-nitro-4-methylphenol, is reduced to form 3-amino-4-methylphenol. A common method for this transformation is catalytic hydrogenation using a catalyst such as Raney nickel under a hydrogen atmosphere. The reaction progress can be monitored by Thin Layer Chromatography (TLC).
- **Sulfonylation:** The resulting 3-amino-4-methylphenol is then reacted with a sulfonating agent, such as chlorosulfonic acid, to introduce the sulfonyl chloride group, yielding 3-amino-4-methylbenzene-1-sulfonyl chloride. This reaction is typically performed at low temperatures to control its reactivity.
- **Urea Formation:** The final step involves the reaction of the sulfonyl chloride intermediate with cyclohexyl isocyanate. This reaction forms the urea linkage, resulting in the final product, **Metahexamide**. The product would then be purified, for example, by recrystallization.

## Characterization Protocols

The synthesized **Metahexamide** would be characterized using standard analytical techniques to confirm its structure and purity.

### 4.2.1. Nuclear Magnetic Resonance (NMR) Spectroscopy

- **Objective:** To elucidate the carbon-hydrogen framework of the molecule.
- **Methodology:**
  - A sample of **Metahexamide** (typically 5-10 mg) is dissolved in a deuterated solvent (e.g., DMSO- $d_6$  or  $CDCl_3$ ) in an NMR tube.
  - $^1H$  NMR and  $^{13}C$  NMR spectra are acquired on a high-field NMR spectrometer (e.g., 400 MHz or higher).
  - The chemical shifts ( $\delta$ ), multiplicity, and integration of the peaks in the  $^1H$  NMR spectrum, and the chemical shifts of the peaks in the  $^{13}C$  NMR spectrum, would be analyzed to confirm the presence of the aromatic, cyclohexyl, methyl, and amine protons and carbons,

consistent with the structure of **Metahexamide**. 2D NMR experiments like COSY and HSQC could be used for more detailed structural assignment.

#### 4.2.2. Infrared (IR) Spectroscopy

- Objective: To identify the functional groups present in the molecule.
- Methodology:
  - An IR spectrum of solid **Metahexamide** is obtained using an FTIR spectrometer, typically employing the KBr pellet or Attenuated Total Reflectance (ATR) technique.
  - The spectrum would be analyzed for characteristic absorption bands corresponding to the functional groups in **Metahexamide**. Expected key peaks would include N-H stretching vibrations for the amine and urea groups, C=O stretching for the urea carbonyl, and S=O stretching for the sulfonyl group.

#### 4.2.3. Mass Spectrometry (MS)

- Objective: To determine the molecular weight and fragmentation pattern of the molecule.
- Methodology:
  - A dilute solution of **Metahexamide** is introduced into a mass spectrometer, often using techniques like Electrospray Ionization (ESI) or Atmospheric Pressure Chemical Ionization (APCI).
  - A full scan mass spectrum is acquired to determine the mass-to-charge ratio ( $m/z$ ) of the molecular ion ( $[M+H]^+$  or  $[M-H]^-$ ), which should correspond to the calculated molecular weight of **Metahexamide**.
  - Tandem mass spectrometry (MS/MS) could be performed to induce fragmentation of the molecular ion, providing further structural information based on the observed fragment ions.

## Mechanism of Action and Signaling Pathway

**Metahexamide**, like other first-generation sulfonylureas, stimulates insulin secretion from pancreatic  $\beta$ -cells by interacting with the ATP-sensitive potassium (K-ATP) channel.

The signaling pathway is initiated by the binding of **Metahexamide** to the sulfonylurea receptor 1 (SUR1) subunit of the K-ATP channel. This binding event leads to the closure of the channel, which in turn depolarizes the cell membrane. The depolarization activates voltage-gated calcium channels, causing an influx of calcium ions into the cell. The elevated intracellular calcium concentration triggers the exocytosis of insulin-containing granules, resulting in the release of insulin into the bloodstream.

Signaling Pathway of **Metahexamide** in Pancreatic  $\beta$ -Cells

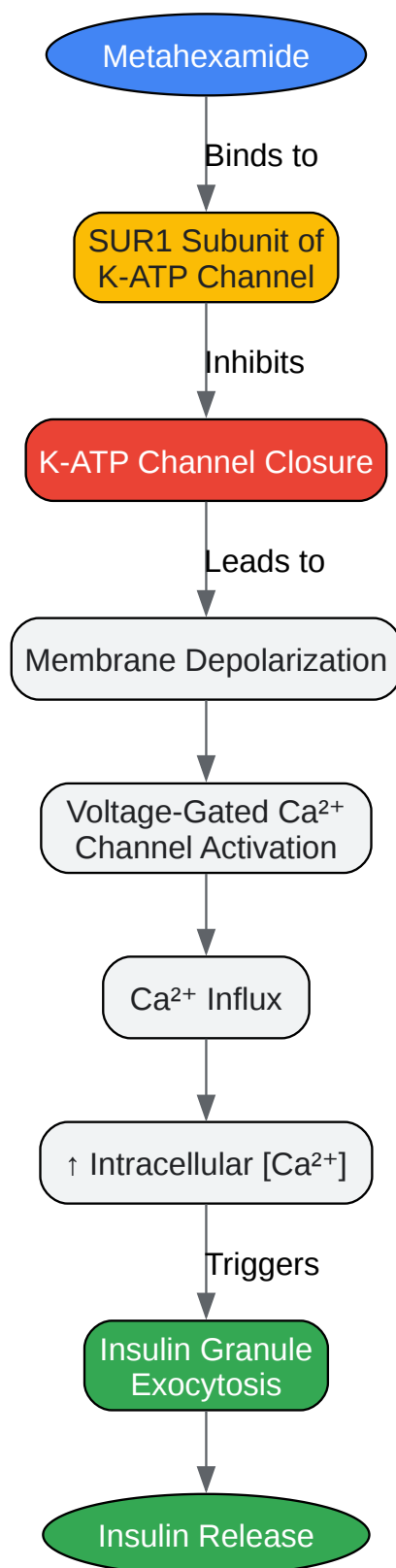

[Click to download full resolution via product page](#)

**Figure 3:** Signaling pathway of **Metahexamide** in pancreatic β-cells.

## Conclusion

**Metahexamide** is a well-characterized first-generation sulfonylurea in terms of its fundamental chemical structure and mechanism of action. While specific, modern experimental data on its synthesis and detailed characterization are not abundant in readily accessible literature, its properties can be reliably predicted and analyzed using standard organic chemistry principles and analytical techniques. This guide provides a foundational understanding of **Metahexamide** for professionals in the field of drug development and research.

### Need Custom Synthesis?

BenchChem offers custom synthesis for rare earth carbides and specific isotopic labeling.

Email: [info@benchchem.com](mailto:info@benchchem.com) or [Request Quote Online](#).

## References

- [1. Metahexamide | C14H21N3O3S | CID 11259 - PubChem \[pubchem.ncbi.nlm.nih.gov\]](#)
- [2. Metahexamide - Wikipedia \[en.wikipedia.org\]](#)
- [3. Facebook \[cancer.gov\]](#)
- [4. GSRS \[precision.fda.gov\]](#)
- To cite this document: BenchChem. [An In-depth Technical Guide to the Chemical Structure of Metahexamide]. BenchChem, [2026]. [Online PDF]. Available at: [\[https://www.benchchem.com/product/b1676324/docs#an-in-depth-technical-guide-to-the-chemical-structure-of-metahexamide\]](https://www.benchchem.com/product/b1676324/docs#an-in-depth-technical-guide-to-the-chemical-structure-of-metahexamide)

---

### Disclaimer & Data Validity:

The information provided in this document is for Research Use Only (RUO) and is strictly not intended for diagnostic or therapeutic procedures. While BenchChem strives to provide accurate protocols, we make no warranties, express or implied, regarding the fitness of this product for every specific experimental setup.

**Technical Support:** The protocols provided are for reference purposes. Unsure if this reagent suits your experiment?

**Need Industrial/Bulk Grade?** [Request Custom Synthesis Quote](#)

## BenchChem

Our mission is to be the trusted global source of essential and advanced chemicals, empowering scientists and researchers to drive progress in science and industry.

### Contact

Address: 3281 E Guasti Rd  
Ontario, CA 91761, United States  
Phone: (601) 213-4426  
Email: [info@benchchem.com](mailto:info@benchchem.com)

[Contact our Ph.D. Support Team for a compatibility check](#)