

Validating the On-Target Effects of LY233053 in Knockout Models: A Comparative Guide

Author: BenchChem Technical Support Team. **Date:** April 2026

Compound of Interest

Compound Name: LY135305
CAS No.: 123199-75-7
Cat. No.: B1675572

[Get Quote](#)

For Researchers, Scientists, and Drug Development Professionals

This guide provides a comprehensive comparison of methodologies for validating the on-target effects of the competitive N-methyl-D-aspartate (NMDA) receptor antagonist, LY233053, with a focus on the use of knockout animal models. The content herein is intended to furnish researchers with the necessary information to design and interpret experiments aimed at confirming the specific molecular target of this and similar compounds.

Introduction to LY233053 and On-Target Validation

LY233053 is a potent and selective competitive antagonist of the NMDA receptor, a crucial ionotropic glutamate receptor involved in synaptic plasticity, learning, and memory.^{[1][2][3]} Exaggerated activation of NMDA receptors is implicated in a variety of neurological disorders, making antagonists like LY233053 valuable research tools and potential therapeutic agents.

"On-target" effects are the physiological or pharmacological consequences of a drug binding to its intended molecular target.^{[4][5]} Validating these effects is a critical step in drug development to ensure efficacy and minimize off-target toxicities. The use of knockout (KO) animal models,

in which the gene encoding the drug's target is deleted, represents a gold-standard approach for such validation.

Comparative Analysis: LY233053 and Alternatives in Knockout Models

While specific studies validating LY233053 in NMDA receptor subunit knockout mice are not readily available in the public domain, the established use of these models for other NMDA receptor antagonists provides a clear framework for comparison. This section outlines the expected outcomes when testing LY233053 and compares them to findings with other well-characterized antagonists.

Table 1: Comparison of Expected and Known On-Target Validation Data in Knockout Models

Compound	Target	Mechanism of Action	Knockout Model	Expected/Known Effect in Wild-Type (WT)	Expected/Known Effect in Knockout (KO)
LY233053	NMDA Receptor	Competitive Antagonist	NMDA Receptor Subunit (e.g., GluN1) KO	- Reduction in NMDA-induced currents- Neuroprotection against excitotoxicity- Anticonvulsant effects	- Abolished or significantly reduced antagonist effect- Lack of neuroprotection by the compound- Absence of anticonvulsant activity
PCP/Ketamine	NMDA Receptor	Non-competitive Channel Blocker	GluN2D KO	- Hyperlocomotion- Disruption of prepulse inhibition	- Blunted hyperlocomotion or response

Experimental Protocols for On-Target Validation

The following are detailed methodologies for key experiments designed to validate the on-target effects of LY233053 using NMDA receptor knockout models.

Electrophysiology in Brain Slices

Objective: To determine if the inhibitory effect of LY233053 on NMDA receptor-mediated synaptic currents is absent in knockout mice.

Protocol:

- Prepare acute brain slices (e.g., from the hippocampus) from both wild-type (WT) and NMDA receptor subunit (e.g., GluN1) knockout (KO) mice.
- Perform whole-cell patch-clamp recordings from pyramidal neurons.
- Isolate NMDA receptor-mediated excitatory postsynaptic currents (EPSCs) by holding the membrane potential at a depolarized level (e.g., +40 mV) in the presence of an AMPA receptor antagonist.
- Evoke EPSCs by stimulating afferent fibers.
- Establish a stable baseline of NMDA receptor-mediated EPSCs.
- Bath-apply LY233053 at a relevant concentration (e.g., 10 μ M) and record the effect on the EPSC amplitude.
- Wash out the drug to observe recovery.
- Compare the percentage of inhibition of the NMDA receptor-mediated EPSC by LY233053 in WT and KO neurons.

In Vivo Neuroprotection Assay

Objective: To assess whether the neuroprotective effects of LY233053 against excitotoxic insults are dependent on the presence of the NMDA receptor.

Protocol:

- Administer a neurotoxic dose of an NMDA receptor agonist (e.g., quinolinic acid) via intrastriatal injection to both WT and NMDA receptor subunit KO mice.
- Treat a subset of animals from both genotypes with a systemic administration of LY233053 prior to the neurotoxin injection.
- After a set period (e.g., 24-48 hours), sacrifice the animals and prepare brain sections.
- Perform histological staining (e.g., Nissl or Fluoro-Jade) to quantify the extent of neuronal damage in the striatum.

- Compare the lesion volumes between vehicle- and LY233053-treated animals in both WT and KO groups.

Visualizing the Validation Workflow and Signaling Pathway

The following diagrams illustrate the conceptual framework for on-target validation and the signaling pathway affected by LY233053.

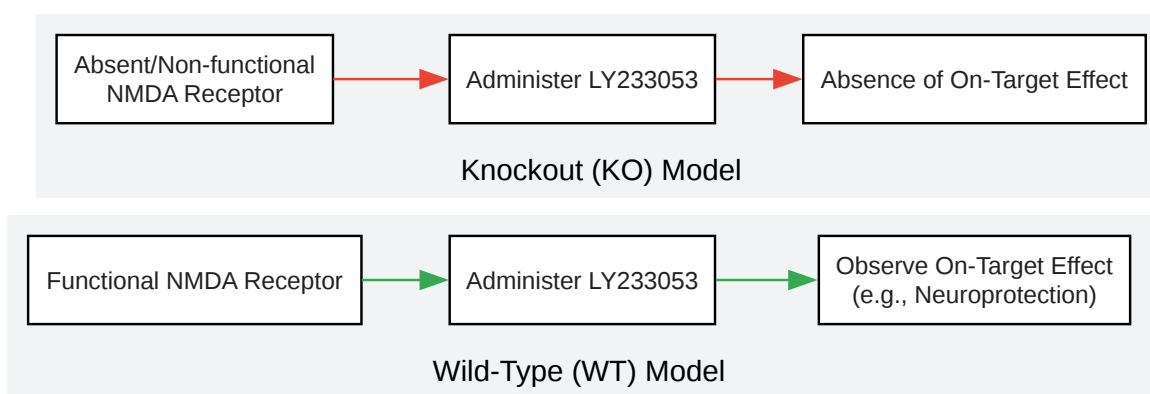

Figure 1. Experimental Workflow for On-Target Validation

[Click to download full resolution via product page](#)

Caption: Workflow comparing the effect of LY233053 in WT and KO models.

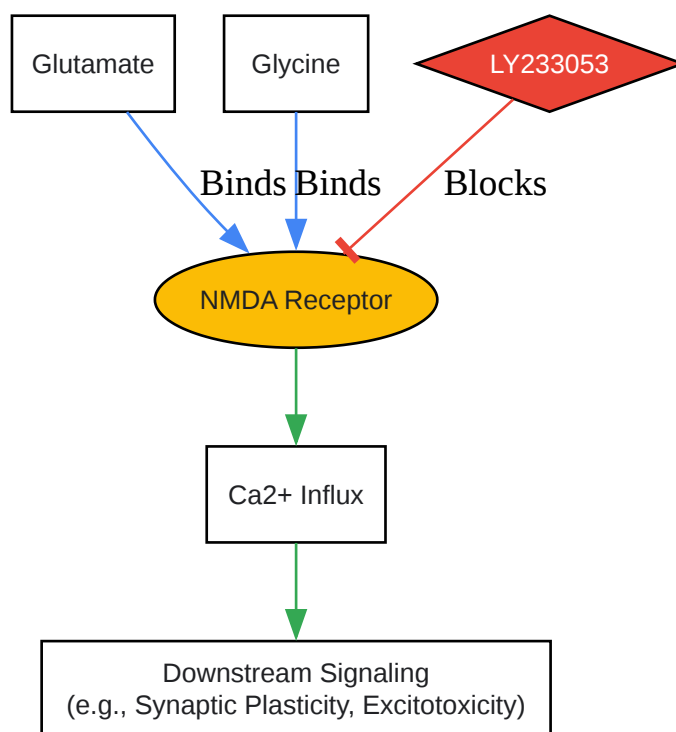

Figure 2. NMDA Receptor Signaling and Point of Intervention

[Click to download full resolution via product page](#)

Caption: Simplified NMDA receptor signaling pathway showing LY233053's action.

Conclusion

The use of knockout models provides an unequivocal method for validating the on-target effects of pharmacological agents. For LY233053, a competitive NMDA receptor antagonist, experiments in NMDA receptor subunit knockout mice are essential to definitively attribute its neuroprotective and anticonvulsant activities to the intended molecular target. The experimental frameworks outlined in this guide offer robust approaches for conducting such validation studies, thereby strengthening the preclinical data package for this and other NMDA receptor-targeting compounds.

Need Custom Synthesis?

BenchChem offers custom synthesis for rare earth carbides and specific isotopic labeling.

Email: info@benchchem.com or [Request Quote Online](#).

References

- 1. [Knockout mouse--its characteristics and application (1): NMDA receptor subunit knockout mouse] - PubMed [pubmed.ncbi.nlm.nih.gov]
- 2. Regulatory roles of the NMDA receptor GluN3A subunit in locomotion, pain perception and cognitive functions in adult mice - PMC [pmc.ncbi.nlm.nih.gov]
- 3. Understanding the role of the NMDA receptor subunit, GluN2D, in mediating NMDA receptor antagonist-induced behavioral disruptions in male and female mice - PMC [pmc.ncbi.nlm.nih.gov]
- 4. Subchronic Pharmacological and Chronic Genetic NMDA Receptor Hypofunction Differentially Regulate the Akt signaling pathway and Arc Expression in Juvenile and Adult mice - PMC [pmc.ncbi.nlm.nih.gov]
- 5. Pharmacophore-driven identification of N-methyl-D-receptor antagonists as potent neuroprotective agents validated using in vivo studies - PMC [pmc.ncbi.nlm.nih.gov]
- To cite this document: BenchChem. [Validating the On-Target Effects of LY233053 in Knockout Models: A Comparative Guide]. BenchChem, [2026]. [Online PDF]. Available at: [<https://www.benchchem.com/product/b1675572/docs#validating-the-on-target-effects-of-ly233053-in-knockout-models-a-comparative-guide>]

Disclaimer & Data Validity:

The information provided in this document is for Research Use Only (RUO) and is strictly not intended for diagnostic or therapeutic procedures. While BenchChem strives to provide accurate protocols, we make no warranties, express or implied, regarding the fitness of this product for every specific experimental setup.

Technical Support: The protocols provided are for reference purposes. Unsure if this reagent suits your experiment?

Need Industrial/Bulk Grade? [Request Custom Synthesis Quote](#)

BenchChem

Our mission is to be the trusted global source of essential and advanced chemicals, empowering scientists and researchers to drive progress in science and industry.

Contact

Address: 3281 E Guasti Rd

Ontario, CA 91761, United States

Phone: (601) 213-4426

Email: info@benchchem.com

[Contact our Ph.D. Support Team for a compatibility check](#)