

Techniques for Assessing LY345899 Target Engagement with MTHFD1 and MTHFD2

Author: BenchChem Technical Support Team. **Date:** December 2025

Compound of Interest

Compound Name: LY 345899

Cat. No.: B1675677

[Get Quote](#)

A Correction on the Molecular Target of LY345899: Initial information suggested an inquiry into LY345899's engagement with the metabotropic glutamate receptors 2 and 3 (mGluR2/3). However, current scientific literature identifies LY345899 as a potent inhibitor of Methylenetetrahydrofolate Dehydrogenase 1 (MTHFD1) and Methylenetetrahydrofolate Dehydrogenase 2 (MTHFD2)[1][2]. This document will therefore focus on the techniques for assessing the target engagement of LY345899 with MTHFD1 and MTHFD2.

These application notes provide detailed protocols for researchers, scientists, and drug development professionals to assess the interaction of LY345899 with its molecular targets, MTHFD1 and MTHFD2.

I. Overview of LY345899 and its Targets

LY345899 is a folate analog that acts as a competitive inhibitor of MTHFD1 and MTHFD2, enzymes crucial for one-carbon metabolism[1][3]. This pathway is vital for the synthesis of nucleotides and other essential biomolecules, and its upregulation is a common feature in various cancers[3]. By inhibiting these enzymes, LY345899 disrupts the production of one-carbon units, leading to cell cycle arrest and apoptosis in cancer cells. MTHFD1 is a cytosolic enzyme, while MTHFD2 is located in the mitochondria.

II. Quantitative Data Summary

The following table summarizes the key quantitative data for LY345899's interaction with its targets.

Parameter	Target	Value	Reference
IC50	MTHFD1	96 nM	
	MTHFD2	663 nM	
Ki	MTHFD1	18 nM	

III. Experimental Protocols

This section details the methodologies for key experiments to assess LY345899 target engagement.

A. Biochemical Enzyme Inhibition Assay

This protocol determines the in vitro potency of LY345899 against recombinant MTHFD1 and MTHFD2.

Principle: The enzymatic activity of MTHFD1/2 is measured by monitoring the production of a detectable product in the presence of varying concentrations of the inhibitor.

Materials:

- Recombinant human MTHFD1 and MTHFD2 proteins
- Substrate (e.g., 5,10-methylenetetrahydrofolate)
- Cofactor (NAD⁺ for MTHFD2, NADP⁺ for MTHFD1)
- Assay buffer (e.g., Tris-HCl, pH 7.5)
- LY345899
- 96-well microplate
- Microplate reader

Procedure:

- Prepare a serial dilution of LY345899 in the assay buffer.
- In a 96-well plate, add the assay buffer, recombinant MTHFD1 or MTHFD2 enzyme, and the diluted LY345899.
- Initiate the reaction by adding the substrate and cofactor.
- Incubate the plate at a controlled temperature (e.g., 37°C) for a specific time.
- Stop the reaction and measure the product formation using a microplate reader (e.g., by monitoring changes in absorbance or fluorescence).
- Plot the enzyme activity against the logarithm of the inhibitor concentration to determine the IC50 value.

B. Cellular Thermal Shift Assay (CETSA)

CETSA is a method to verify direct binding of a compound to its target protein in a cellular context.

Principle: The binding of a ligand (LY345899) to its target protein (MTHFD1/2) can increase the thermal stability of the protein.

Materials:

- Cancer cell line expressing MTHFD1 and MTHFD2 (e.g., HL-60)
- LY345899
- Cell lysis buffer
- PBS
- PCR tubes or strips
- Thermal cycler
- SDS-PAGE and Western blotting reagents

- Antibodies against MTHFD1 and MTHFD2

Procedure:

- Treat cultured cells with either vehicle or LY345899 for a specified time.
- Harvest and wash the cells with PBS.
- Resuspend the cells in PBS and divide them into aliquots in PCR tubes.
- Heat the cell suspensions at a range of temperatures in a thermal cycler for a few minutes.
- Lyse the cells by freeze-thaw cycles.
- Separate the soluble fraction (containing stabilized protein) from the precipitated fraction by centrifugation.
- Analyze the soluble fractions by SDS-PAGE and Western blotting using antibodies specific for MTHFD1 and MTHFD2.
- A shift in the melting curve to higher temperatures in the LY345899-treated samples compared to the vehicle control indicates target engagement.

C. Drug Affinity Responsive Target Stability (DARTS)

DARTS is another technique to identify and validate drug-protein interactions in a native cellular environment.

Principle: Ligand binding can protect a target protein from proteolysis.

Materials:

- Cancer cell line expressing MTHFD1 and MTHFD2
- LY345899
- M-PER or similar cell lysis buffer
- Protease (e.g., thermolysin or pronase)

- SDS-PAGE and Western blotting reagents
- Antibodies against MTHFD1 and MTHFD2

Procedure:

- Lyse the cultured cells to obtain a native protein lysate.
- Divide the lysate into aliquots and treat with either vehicle or varying concentrations of LY345899.
- Incubate the mixtures to allow for binding.
- Add a protease to each aliquot and incubate for a specific time to allow for digestion.
- Stop the digestion by adding a protease inhibitor or by heat inactivation.
- Analyze the samples by SDS-PAGE and Western blotting using antibodies for MTHFD1 and MTHFD2.
- Increased band intensity for MTHFD1/2 in the LY345899-treated samples compared to the vehicle control indicates protection from proteolysis and thus, target engagement.

IV. Visualizations

Signaling Pathway

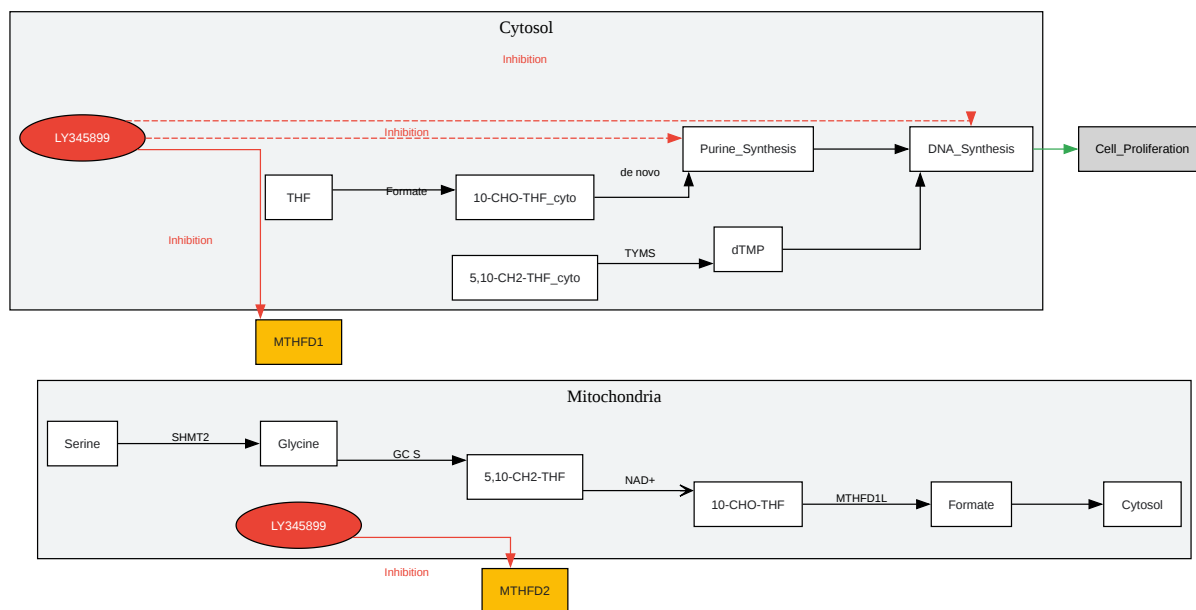

[Click to download full resolution via product page](#)

Caption: LY345899 inhibits MTHFD1/2 in one-carbon metabolism.

Experimental Workflow: Cellular Thermal Shift Assay (CETSA)

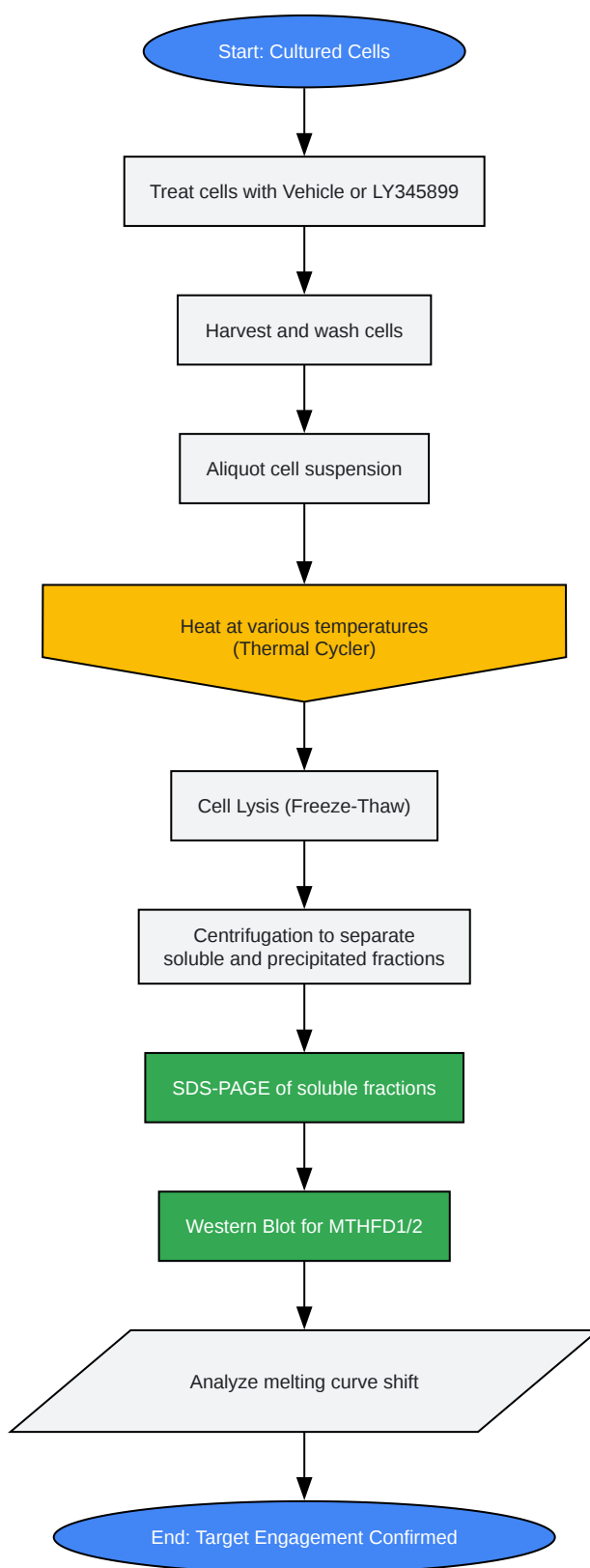

[Click to download full resolution via product page](#)

Caption: Workflow for assessing target engagement using CETSA.

Experimental Workflow: Drug Affinity Responsive Target Stability (DARTS)

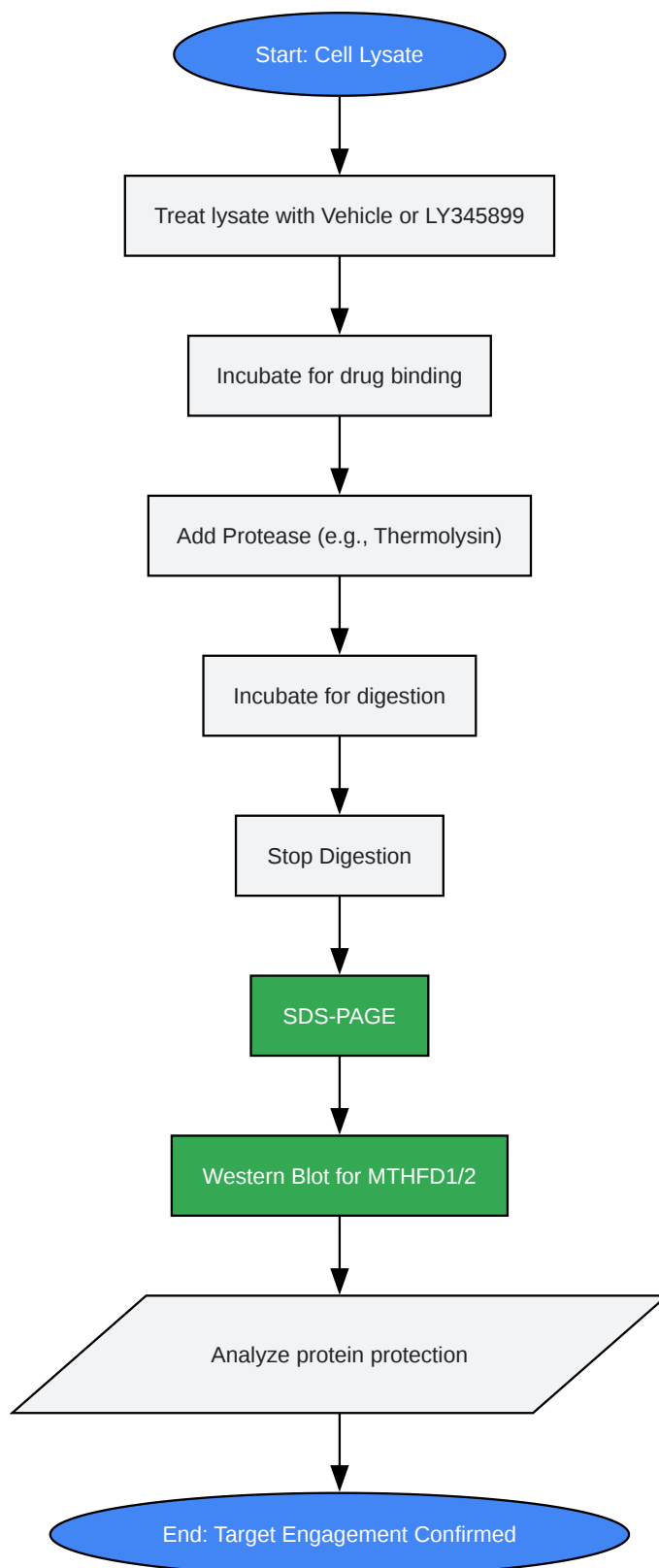

[Click to download full resolution via product page](#)

Caption: Workflow for assessing target engagement using DARTS.

Need Custom Synthesis?

BenchChem offers custom synthesis for rare earth carbides and specific isotopic labeling.

Email: info@benchchem.com or [Request Quote Online](#).

References

- 1. medchemexpress.com [medchemexpress.com]
- 2. aacrjournals.org [aacrjournals.org]
- 3. benchchem.com [benchchem.com]
- To cite this document: BenchChem. [Techniques for Assessing LY345899 Target Engagement with MTHFD1 and MTHFD2]. BenchChem, [2025]. [Online PDF]. Available at: [https://www.benchchem.com/product/b1675677#techniques-for-assessing-ly-345899-target-engagement]

Disclaimer & Data Validity:

The information provided in this document is for Research Use Only (RUO) and is strictly not intended for diagnostic or therapeutic procedures. While BenchChem strives to provide accurate protocols, we make no warranties, express or implied, regarding the fitness of this product for every specific experimental setup.

Technical Support: The protocols provided are for reference purposes. Unsure if this reagent suits your experiment? [[Contact our Ph.D. Support Team for a compatibility check](#)]

Need Industrial/Bulk Grade? [Request Custom Synthesis Quote](#)

BenchChem

Our mission is to be the trusted global source of essential and advanced chemicals, empowering scientists and researchers to drive progress in science and industry.

Contact

Address: 3281 E Guasti Rd
Ontario, CA 91761, United States
Phone: (601) 213-4426
Email: info@benchchem.com