

Technical Support Center: (S)-Lorazepam Acetate Dose-Response Optimization

Author: BenchChem Technical Support Team. **Date:** April 2026

Compound of Interest

Compound Name: (S)-Lorazepam acetate

CAS No.: 84799-34-8

Cat. No.: B1675126

[Get Quote](#)

Welcome to the Technical Support Center for **(S)-Lorazepam acetate** (CAS: 84799-34-8)[1]. This guide is designed for researchers and drug development professionals conducting in vitro pharmacological profiling, electrophysiology, and binding assays. It provides field-proven troubleshooting strategies, mechanistic insights, and validated protocols to ensure high-fidelity dose-response data.

I. Frequently Asked Questions (FAQs) & Troubleshooting

Q1: Why does my (S)-lorazepam acetate dose-response curve exhibit a biphasic profile (potentiation followed by inhibition)?

Causality: **(S)-Lorazepam acetate** is a positive allosteric modulator (PAM) that binds with high affinity to the cleft between the α and γ subunits of the pentameric GABA A receptor[2]. At nanomolar to low-micromolar concentrations, it increases the binding affinity of GABA, thereby increasing the frequency of chloride channel opening. However, at higher concentrations (>10–

30 μM), benzodiazepines can interact with low-affinity inhibitory sites within the ion channel pore or cause non-specific lipid bilayer disruptions, leading to receptor desensitization or direct channel block. Resolution:

- Cap the Concentration: Limit the upper bound of your dose-response curve to 10 μM .
- Vehicle Control: Ensure the DMSO concentration remains strictly constant ($\leq 0.1\%$ v/v) across all dilutions. DMSO itself can independently modulate GABA A receptor currents at higher concentrations, artificially skewing the upper asymptote of your curve.

Q2: The calculated K_i and EC_{50} values for (S)-lorazepam acetate are highly variable between biological replicates. How can I stabilize these metrics?

Causality: **(S)-Lorazepam acetate** exhibits potent and stereoselective allosteric binding to carrier proteins like Human Serum Albumin (HSA). It has been shown to allosterically alter the binding kinetics of other ligands (e.g., warfarin, ibuprofen) at Sudlow's sites[3],[4]. If your assay buffer contains Bovine Serum Albumin (BSA) as a blocking agent, or if your membrane preparations are insufficiently washed, the drug will partition into these proteins, drastically reducing the free aqueous concentration available to bind the GABA A receptor. Resolution:

- Eliminate BSA: Remove BSA from all assay and wash buffers. Use low-protein-binding plastics (e.g., polypropylene) to prevent non-specific adsorption.
- Membrane Washing: Incorporate at least three ultracentrifugation wash steps during crude membrane preparation to remove endogenous plasma proteins[5].

Q3: My stock solutions seem to lose functional potency over time. What is the optimal handling procedure?

Causality: The acetate ester at the C3 position of the diazepam ring is susceptible to spontaneous hydrolysis in aqueous environments, converting the prodrug back to (S)-lorazepam[6]. Furthermore, the chiral center at C3 can undergo racemization to the (R)-enantiomer in polar protic solvents at physiological pH, diluting the stereospecific activity. Resolution:

- Anhydrous Storage: Reconstitute the lyophilized powder exclusively in 100% anhydrous DMSO.
- Aliquoting: Store in single-use aliquots at -80°C. Never subject the stock to freeze-thaw cycles.
- Just-in-Time Dilution: Dilute into aqueous extracellular recording solutions (e.g., ACSF or Ringer's) immediately (<15 minutes) prior to perfusion[7].

II. Quantitative Data & Reference Parameters

To benchmark your assay's performance, compare your empirical data against these established pharmacological parameters for lorazepam derivatives.

Table 1: Expected Pharmacological Parameters for Lorazepam Analogues

Compound	Target / Subtype	Affinity (Ki)	Functional Potency (EC50)	Notes
(S)-Lorazepam acetate	GABA A($\alpha 1\beta 2\gamma 2$)	1.5 – 5.0 nM	15 – 40 nM	Requires strict DMSO control (<0.1%)
Lorazepam (Racemic)	GABA A(Non-selective)	~1 – 10 nM[7]	11.3 – 39.8 ng/mL	In vivo plasma effective concentration[8]
Diazepam (Reference)	GABA A(Non-selective)	10 – 20 nM	50 – 100 nM	Use as an internal assay calibrator

III. Experimental Workflows & Methodologies

Protocol 1: Two-Electrode Voltage Clamp (TEVC)

Functional Assay

This protocol measures the functional potentiation of GABA-evoked chloride currents by **(S)-lorazepam acetate** using *Xenopus laevis* oocytes expressing recombinant human GABA A receptors[7].

Step-by-Step Methodology:

- **Oocyte Preparation:** Inject defolliculated *Xenopus* oocytes with a cRNA mixture encoding the desired GABA A receptor subunits (e.g., $\alpha 1$, $\beta 2$, $\gamma 2$ in a 1:1:2 ratio to ensure $\gamma 2$ incorporation). Incubate at 18°C for 2–7 days[7].
- **Electrophysiological Setup:** Place a single oocyte in the recording chamber and perfuse continuously with standard frog Ringer's solution. Impale with two KCl-filled microelectrodes (0.5–2 M Ω resistance).
- **Voltage Clamp:** Clamp the membrane potential at a holding potential of -70 mV[7].
- **Baseline Establishment (EC₁₀GABA):** Apply a sub-maximal concentration of GABA (typically EC₅ to EC₁₀, ~0.5 μ M for $\alpha 1$ -containing receptors) for 3–5 seconds to elicit a stable baseline inward chloride current[9].
- **Compound Co-application:** Co-apply the baseline GABA concentration alongside **(S)-lorazepam acetate** (ranging from 0.1 nM to 10 μ M).
- **Washout & Recovery:** Wash with Ringer's solution for 3–5 minutes between applications to prevent receptor desensitization (rundown).
- **Self-Validation Step:** The maximum potentiation (efficacy) should plateau. If the current fails to return to baseline during washout, discard the oocyte due to irreversible membrane destabilization.

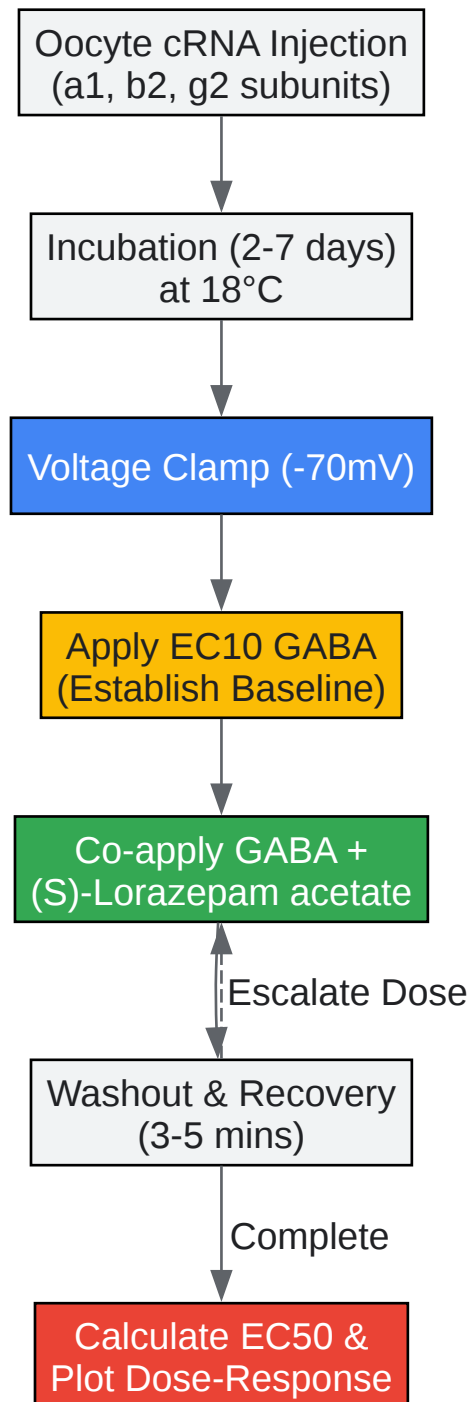

[Click to download full resolution via product page](#)

TEVC experimental workflow for GABA_A PAM dose-response curve generation.

Protocol 2: Radioligand Binding Displacement Assay

This protocol determines the binding affinity (K_i) of **(S)-lorazepam acetate** by measuring its ability to displace the competitive radioligand [^3H]-flumazenil[7],[9].

Step-by-Step Methodology:

- Membrane Preparation: Homogenize rat cerebral cortex (or transfected HEK293 cells) in cold 50 mM Tris-HCl buffer (pH 7.4). Centrifuge at 40,000 x g for 20 minutes. Wash the pellet three times to remove endogenous GABA and plasma proteins[5],[7].
- Assay Assembly: In a 96-well plate, combine:
 - 50 μL of [^3H]-flumazenil (final concentration $\sim 1\text{ nM}$).
 - 50 μL of **(S)-lorazepam acetate** at varying concentrations (10^{-11} to 10^{-5} M).
 - 100 μL of membrane suspension (approx. 50 μg protein/well)[9].
- Incubation: Incubate the mixture at 4°C for 60 minutes to reach equilibrium.
- Termination: Terminate the reaction by rapid vacuum filtration through GF/B glass fiber filters (pre-soaked in 0.3% polyethylenimine to reduce non-specific binding). Wash filters rapidly with 3 x 3 mL of ice-cold Tris-HCl buffer[9].
- Quantification: Add scintillation cocktail to the filters and count radioactivity using a liquid scintillation counter[7].
- Data Analysis: Determine the IC_{50} using non-linear regression. Calculate the K_i using the Cheng-Prusoff equation: $K_i = \text{IC}_{50} / (1 + [L] / K_d)$ [7].
- Self-Validation Step: Include a well with 10 μM diazepam to define Non-Specific Binding (NSB). NSB should be $< 10\%$ of total binding.

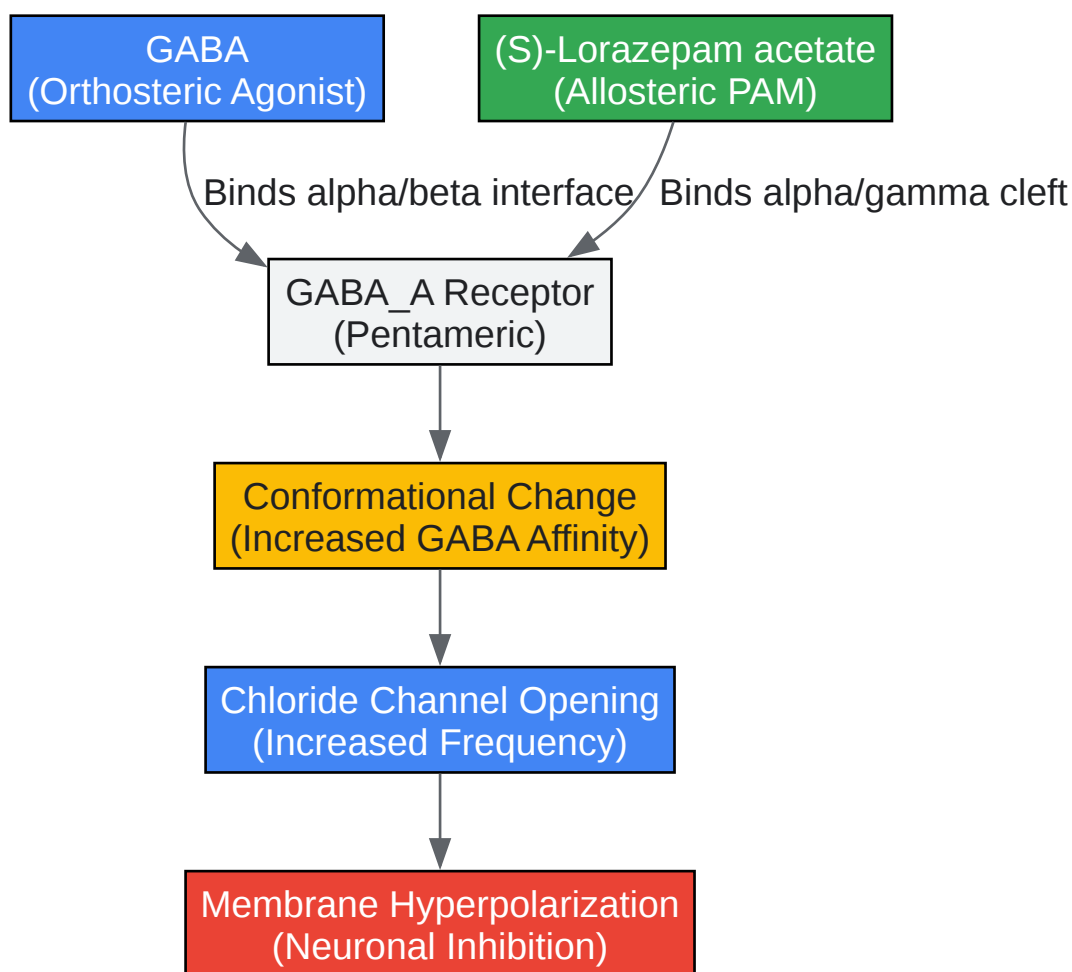

[Click to download full resolution via product page](#)

GABA_A receptor allosteric modulation pathway by **(S)-Lorazepam acetate**.

V. References

- ClinPGx. "Lorazepam Pharmacodynamics and Pharmacogenetics." Clinical Pharmacogenetics Knowledgebase. Available at: [\[Link\]](#)
- Fitos, I., et al. "Effect of (S)-LoAc on the kinetics of the interactions between warfarin enantiomers and HSA." ResearchGate. Available at: [\[Link\]](#)
- Hage, D. S., et al. "Quantitative analysis of allosteric drug-protein binding by biointeraction chromatography." PubMed / NIH. Available at: [\[Link\]](#)

- Nickolls, S. A., et al. "Pharmacology in translation: the preclinical and early clinical profile of the novel α 2/3 functionally selective GABAA receptor positive allosteric modulator PF-06372865." PMC / NIH. Available at: [\[Link\]](#)
- Benke, D., & Mohler, H. "Benzodiazepine binding to GABA(A) receptors." ResearchGate. Available at: [\[Link\]](#)
- Schiwy, W., et al. "Pharmacokinetic and Pharmacodynamic Analysis of Sedative and Amnesic Effects of Lorazepam in Healthy Volunteers." ResearchGate. Available at: [\[Link\]](#)

Need Custom Synthesis?

BenchChem offers custom synthesis for rare earth carbides and specific isotopic labeling.

Email: info@benchchem.com or [Request Quote Online](#).

Sources

- 1. (S)-Lorazepam acetate | 84799-34-8 [m.chemicalbook.com]
- 2. ClinPGx [clinpgx.org]
- 3. researchgate.net [researchgate.net]
- 4. Quantitative analysis of allosteric drug-protein binding by biointeraction chromatography - PubMed [pubmed.ncbi.nlm.nih.gov]
- 5. researchgate.net [researchgate.net]
- 6. CAS 2848-96-6: Lorazepam acetate | CymitQuimica [cymitquimica.com]
- 7. pdf.benchchem.com [pdf.benchchem.com]
- 8. researchgate.net [researchgate.net]
- 9. Pharmacology in translation: the preclinical and early clinical profile of the novel α 2/3 functionally selective GABAA receptor positive allosteric modulator PF-06372865 - PMC [pmc.ncbi.nlm.nih.gov]
- To cite this document: BenchChem. [Technical Support Center: (S)-Lorazepam Acetate Dose-Response Optimization]. BenchChem, [2026]. [Online PDF]. Available at: [<https://www.benchchem.com/product/b1675126/docs#technical-support-center-s-lorazepam-acetate-dose-response-optimization>]

Disclaimer & Data Validity:

The information provided in this document is for Research Use Only (RUO) and is strictly not intended for diagnostic or therapeutic procedures. While BenchChem strives to provide accurate protocols, we make no warranties, express or implied, regarding the fitness of this product for every specific experimental setup.

Technical Support: The protocols provided are for reference purposes. Unsure if this reagent suits your experiment?

Need Industrial/Bulk Grade? [Request Custom Synthesis Quote](#)

BenchChem

Our mission is to be the trusted global source of essential and advanced chemicals, empowering scientists and researchers to drive progress in science and industry.

Contact

Address: 3281 E Guasti Rd
Ontario, CA 91761, United States
Phone: (601) 213-4426
Email: info@benchchem.com

[Contact our Ph.D. Support Team for a compatibility check](#)