

# An In-depth Technical Guide to the Biological Activities of Loureirin B

**Author:** BenchChem Technical Support Team. **Date:** December 2025

## Compound of Interest

Compound Name: Loureirin B

Cat. No.: B1675249

[Get Quote](#)

Authored for Researchers, Scientists, and Drug Development Professionals

## Abstract

**Loureirin B**, a flavonoid and a primary bioactive constituent of Resina Draconis (Dragon's Blood), has garnered significant scientific interest for its diverse pharmacological properties. This technical guide provides a comprehensive review of the biological activities of **Loureirin B**, with a focus on its anti-cancer, anti-inflammatory, neuroprotective, and metabolic regulatory effects. This document synthesizes quantitative data from multiple studies, outlines key experimental methodologies, and presents visual representations of the underlying signaling pathways to facilitate a deeper understanding of its therapeutic potential.

## Introduction

**Loureirin B**, with the chemical formula  $C_{18}H_{20}O_5$ , is a dihydrochalcone that has been traditionally used in Chinese medicine.<sup>[1]</sup> Modern pharmacological studies have begun to elucidate the molecular mechanisms underpinning its therapeutic effects. This guide serves as a technical resource for researchers and professionals in the field of drug discovery and development, providing a consolidated overview of the current state of knowledge regarding **Loureirin B**'s biological functions.

## Anti-Cancer Activities

**Loureirin B** has demonstrated significant anti-cancer activity across various cancer cell lines. Its mechanisms of action primarily involve the induction of apoptosis, cell cycle arrest, and inhibition of cell proliferation, invasion, and migration.

## Signaling Pathways in Anti-Cancer Activity

A key pathway implicated in **Loureirin B**'s anti-cancer effects is the PI3K/AKT signaling cascade. In cervical cancer cells (HeLa), **Loureirin B** has been shown to suppress this pathway, leading to reduced cell viability and proliferation.[2] Furthermore, studies on colorectal cancer have indicated that **Loureirin B** analogues can regulate the cell cycle and the Fas death receptor pathway.[3]

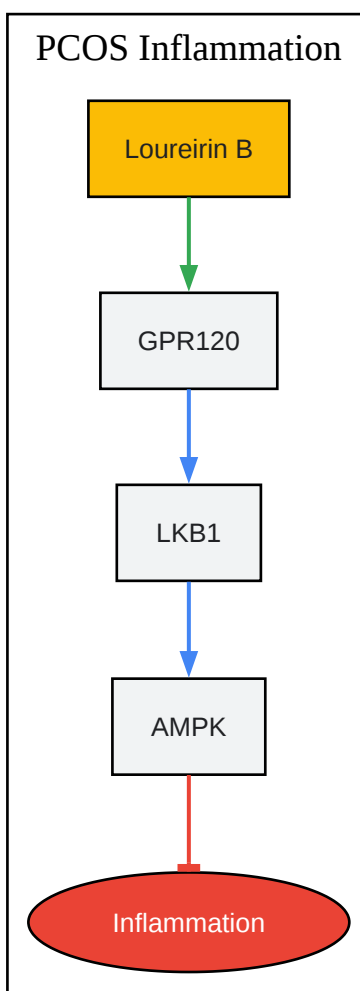
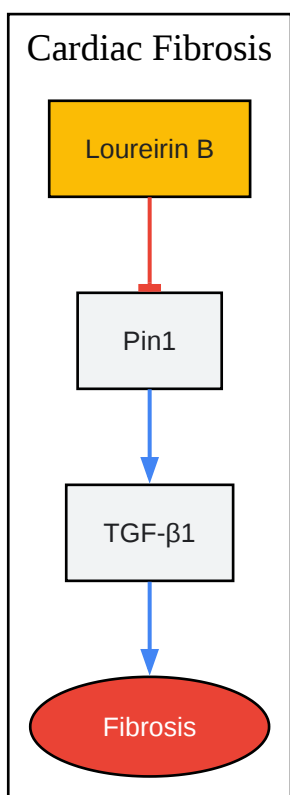
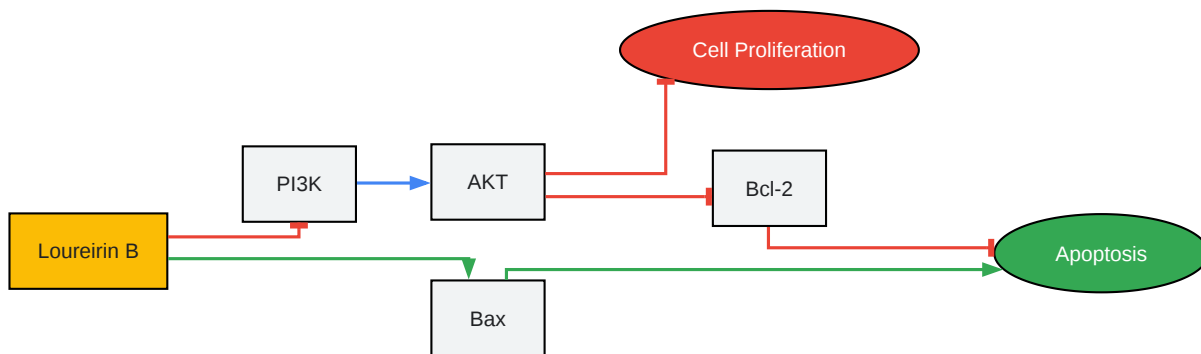

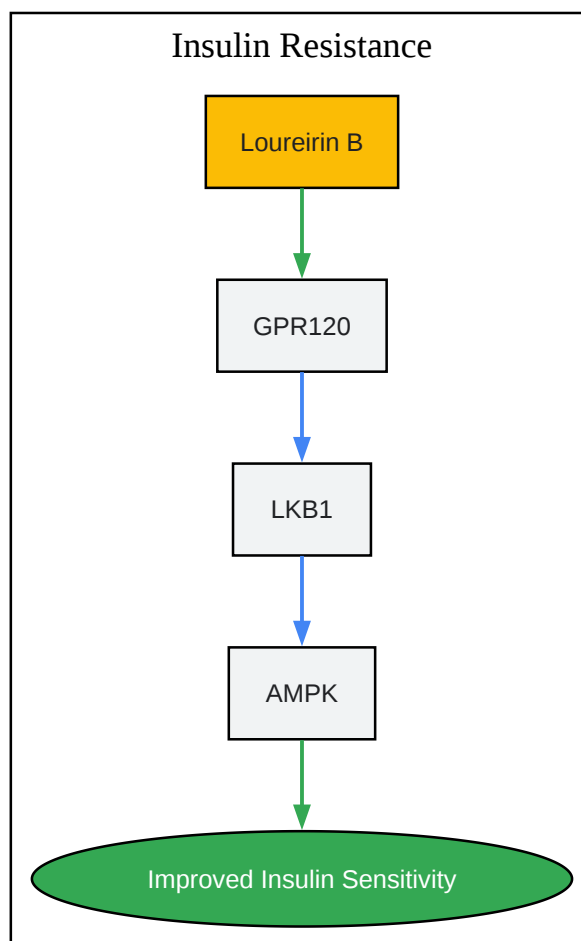
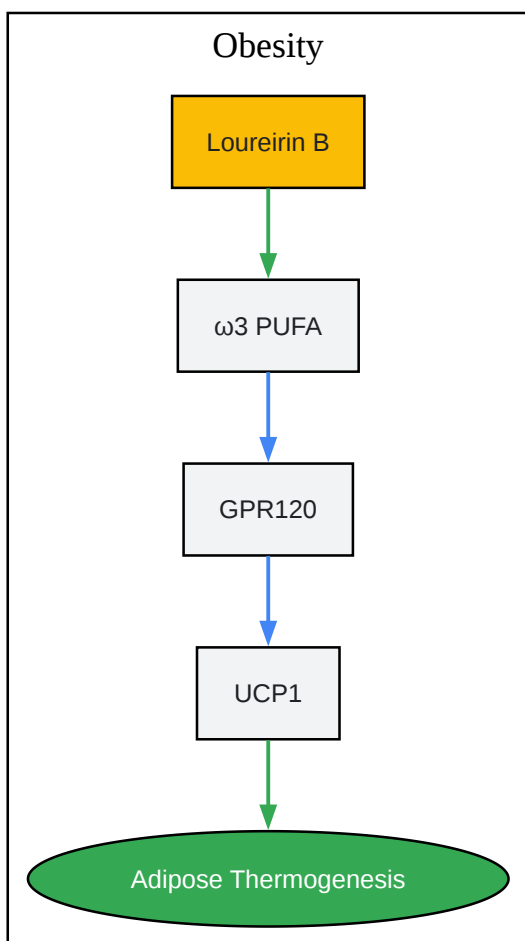
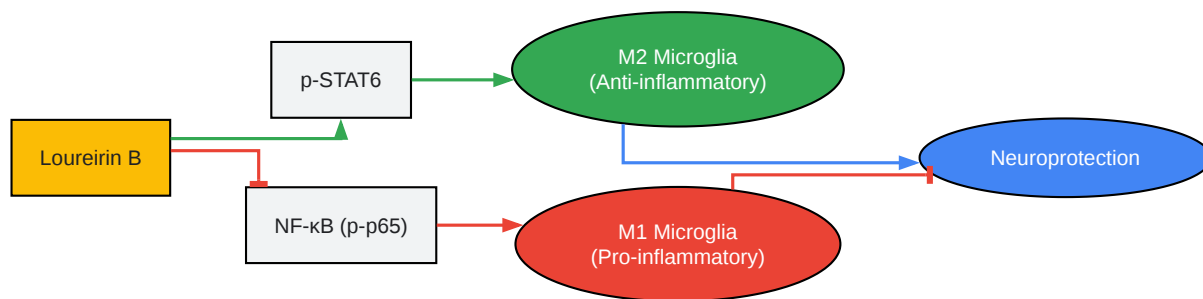

[Click to download full resolution via product page](#)

**Need Custom Synthesis?**

BenchChem offers custom synthesis for rare earth carbides and specific isotopic labeling.

Email: [info@benchchem.com](mailto:info@benchchem.com) or [Request Quote Online](#).

## References

- 1. Loureirin B | C18H20O5 | CID 189670 - PubChem [pubchem.ncbi.nlm.nih.gov]
- 2. researchgate.net [researchgate.net]
- 3. Discovery of Loureirin analogues with colorectal cancer suppressive activity via regulating cell cycle and Fas death receptor - PMC [pmc.ncbi.nlm.nih.gov]
- To cite this document: BenchChem. [An In-depth Technical Guide to the Biological Activities of Loureirin B]. BenchChem, [2025]. [Online PDF]. Available at: [https://www.benchchem.com/product/b1675249#review-of-loureirin-b-biological-activities]

---

### Disclaimer & Data Validity:

The information provided in this document is for Research Use Only (RUO) and is strictly not intended for diagnostic or therapeutic procedures. While BenchChem strives to provide accurate protocols, we make no warranties, express or implied, regarding the fitness of this product for every specific experimental setup.

**Technical Support:** The protocols provided are for reference purposes. Unsure if this reagent suits your experiment? [[Contact our Ph.D. Support Team for a compatibility check](#)]

**Need Industrial/Bulk Grade?** [Request Custom Synthesis Quote](#)

## BenchChem

Our mission is to be the trusted global source of essential and advanced chemicals, empowering scientists and researchers to drive progress in science and industry.

### Contact

Address: 3281 E Guasti Rd  
Ontario, CA 91761, United States  
Phone: (601) 213-4426  
Email: [info@benchchem.com](mailto:info@benchchem.com)