

Technical Guide: Cross-Validation of L-Leucyl-L-alanine Quantification

Author: BenchChem Technical Support Team. **Date:** May 2026

Compound of Interest

Compound Name: *L-Leucyl-L-alanine*

CAS No.: 7298-84-2

Cat. No.: B1674815

[Get Quote](#)

Executive Summary

L-Leucyl-L-alanine (Leu-Ala) is a critical dipeptide often utilized as a physicochemical standard for peptide transport studies, a degradation marker in proteolytic assays, and a stability indicator in parenteral nutrition formulations. Its quantification presents a classic analytical dichotomy: the molecule lacks a strong chromophore, making standard UV detection non-specific, yet it is highly polar, challenging standard Reversed-Phase (RP) retention.

This guide provides a rigorous cross-validation framework comparing the two industry-standard approaches: HILIC-MS/MS (Method A), representing the gold standard for sensitivity and specificity in biological matrices, and Ion-Pairing RP-HPLC-UV (Method B), the accessible, robust alternative for QC and stability testing.

Part 1: Analytical Strategy & Causality

As senior scientists, we do not simply "run samples"; we interrogate the chemistry to select the correct tool.

Method A: HILIC-MS/MS (The Bioanalytical Gold Standard)

Context: Required for plasma, cell lysate, or complex media where sensitivity (<10 ng/mL) is paramount.

- Mechanism: Hydrophilic Interaction Liquid Chromatography (HILIC) retains the polar zwitterionic dipeptide without derivatization.
- Detection: Positive Electrospray Ionization (ESI+) in Multiple Reaction Monitoring (MRM) mode.
- Causality: We use HILIC because Leu-Ala elutes in the void volume of C18 columns. We use MS/MS because the peptide bond absorption (210 nm) is indistinguishable from matrix noise in plasma.

Method B: Ion-Pairing RP-HPLC-UV (The QC Workhorse)

Context: Ideal for formulation stability, purity analysis, and degradation studies in simple buffers.

- Mechanism: Use of an ion-pairing reagent (e.g., Hexanesulfonic acid) or perfluorinated acid (TFA/HFBA) to neutralize the N-terminus charge, inducing hydrophobicity and retention on a C18 stationary phase.
- Detection: UV at 210–215 nm (peptide bond).
- Causality: We accept lower specificity for higher precision (RSD < 0.5%) and lower cost. This method fails in plasma due to interference but excels in defined aqueous solutions.

Part 2: Experimental Protocols

Materials & Reagents

- Analyte: **L-Leucyl-L-alanine** (CAS: 7298-84-2), >99% purity.
- Internal Standard (IS): **L-Leucyl-L-alanine-d3** (Leucine-d3) or Gly-Phe (structural analog if isotope unavailable).

- Matrices: Spiked Human Plasma (Bioanalysis) and Phosphate Buffer pH 7.4 (Stability).

Method A: HILIC-MS/MS Protocol

System: Triple Quadrupole MS coupled to UHPLC.

- Column: Amide or Zwitterionic HILIC (e.g., 2.1 x 100 mm, 1.7 μ m).
- Mobile Phase A: 10 mM Ammonium Formate in Water, pH 3.0 (Buffers ionization).
- Mobile Phase B: Acetonitrile (ACN).
- Gradient: 90% B to 50% B over 5 min. (High organic start is critical for HILIC retention).
- MS Transitions:
 - Quantifier: m/z 203.1
86.1 (Leu immonium ion).
 - Qualifier: m/z 203.1
132.1.
- Self-Validating Step: Monitor the IS area stability. If IS variation >15% between injections, trigger a system re-equilibration check.

Method B: Ion-Pairing HPLC-UV Protocol

System: HPLC with DAD/VWD.

- Column: C18 End-capped (4.6 x 150 mm, 3.5 or 5 μ m).
- Mobile Phase: Isocratic 20% ACN / 80% Water containing 0.1% Trifluoroacetic Acid (TFA) or 5 mM Sodium Hexanesulfonate (pH 2.5).
- Flow Rate: 1.0 mL/min.
- Detection: 210 nm.

- Self-Validating Step: Resolution check () between Leu-Ala and its hydrolysis products (Leucine and Alanine). must be > 2.0.

Part 3: Cross-Validation Workflow (The "Bridge" Study)

To validate Method B against Method A, we employ a Bland-Altman analysis rather than simple correlation (

), which can hide systematic bias.

Experimental Design

- Sample Set: Prepare 30 samples spanning the concentration range 10 μM – 1 mM (QC High, Mid, Low).
- Split Analysis: Aliquot each sample into two vials. Run on System A and System B within 24 hours to negate stability issues.
- Data Treatment: Calculate the % Difference and Absolute Difference for each pair.

Visualizing the Logic

The following diagram illustrates the decision matrix and validation flow for selecting and comparing these methods.

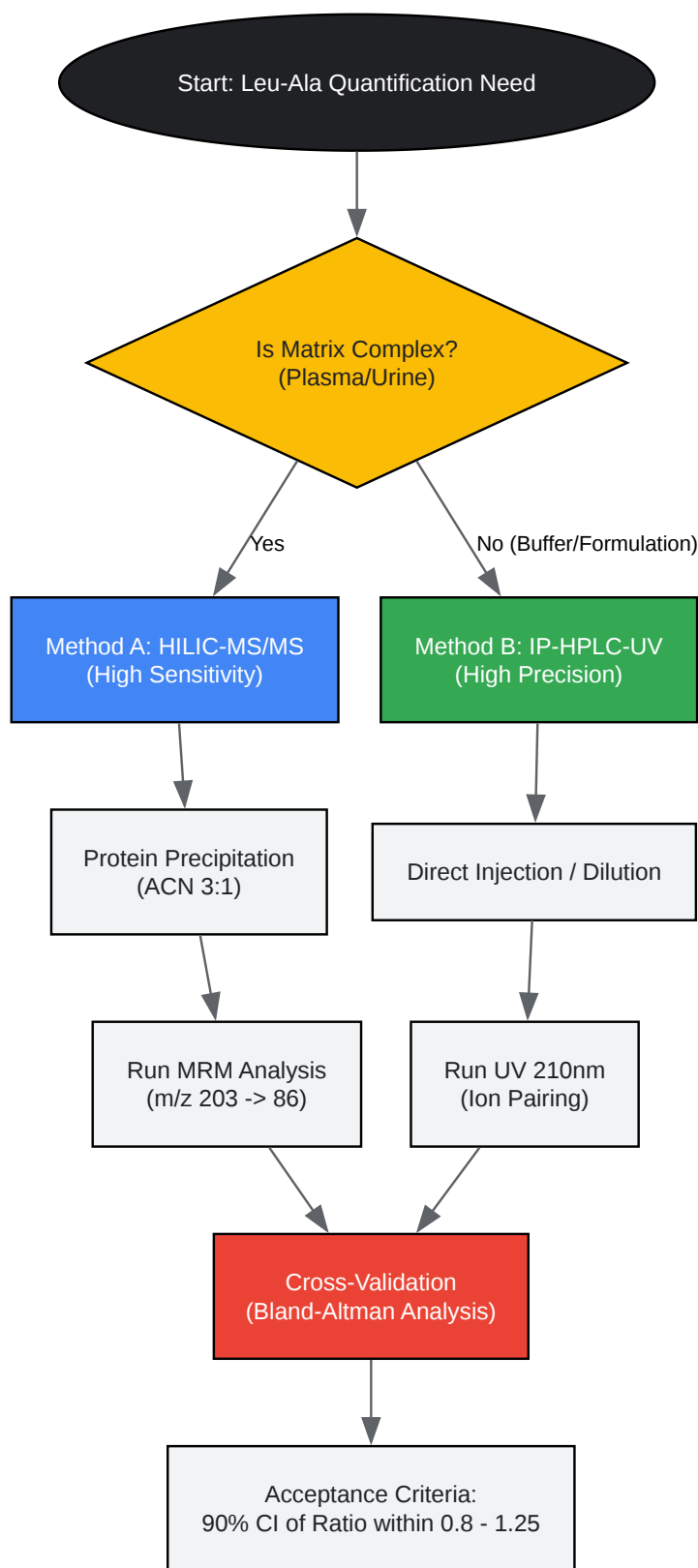

[Click to download full resolution via product page](#)

Figure 1: Decision tree and cross-validation workflow for **L-Leucyl-L-alanine** analysis.

Part 4: Data Presentation & Acceptance Criteria

When publishing your comparison, organize data to highlight the range of applicability rather than just "pass/fail".

Comparative Performance Table

Parameter	Method A: HILIC-MS/MS	Method B: IP-HPLC-UV
Linearity Range	1 ng/mL – 1000 ng/mL	1 µg/mL – 1000 µg/mL
Specificity	High (Mass-selective)	Low (Interference prone at 210nm)
Precision (RSD)	2.0% – 5.0%	< 0.5%
Matrix Effect	Susceptible (Ion Suppression)	Susceptible (Baseline Noise)
Throughput	5 min / sample	15-20 min / sample

Statistical Validation (Bland-Altman)

To prove Method B is a valid surrogate for Method A in QC settings:

- Plot

vs.

.

- Bias Calculation: The mean difference should not be significantly different from zero ($p > 0.05$).
- Limits of Agreement: 95% of data points must fall within
of the difference.

Part 5: Troubleshooting & Mechanism

Understanding the fragmentation of Leu-Ala is critical for MS optimization. The loss of the C-terminal alanine or the immonium ion formation drives the sensitivity.

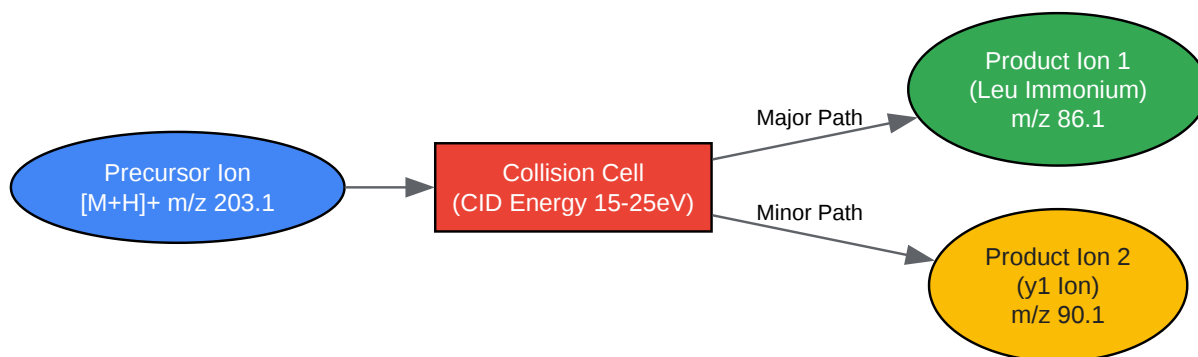

[Click to download full resolution via product page](#)

Figure 2: MS/MS Fragmentation pathway for **L-Leucyl-L-alanine** (Precursor m/z 203.1).

References

- ICH Harmonised Tripartite Guideline. (2005). Validation of Analytical Procedures: Text and Methodology Q2(R1). International Council for Harmonisation.[1] [\[Link\]](#)
- Bland, J. M., & Altman, D. G. (1986). Statistical methods for assessing agreement between two methods of clinical measurement.[2] *The Lancet*, 327(8476), 307-310. [\[Link\]](#)
- Vig, B. S., et al. (2003). Stability of **L-leucyl-L-alanine** in aqueous solution. *Journal of Pharmaceutical and Biomedical Analysis*, 33(5), 1051-1061. [\[Link\]](#)
- Food and Drug Administration (FDA). (2018). Bioanalytical Method Validation Guidance for Industry.[3][\[Link\]](#)
- Tolle, S., et al. (2013). HILIC-MS/MS for the determination of dipeptides in cell culture media. *Analytical and Bioanalytical Chemistry*, 405, 7949–7956. [\[Link\]](#)

Need Custom Synthesis?

BenchChem offers custom synthesis for rare earth carbides and specific isotopic labeling.

Email: info@benchchem.com or [Request Quote Online](#).

Sources

- [1. fda.gov \[fda.gov\]](https://www.fda.gov)
- [2. Cross validation of pharmacokinetic bioanalytical methods: Experimental and statistical design - PubMed \[pubmed.ncbi.nlm.nih.gov\]](https://pubmed.ncbi.nlm.nih.gov)
- [3. chromatographyonline.com \[chromatographyonline.com\]](https://www.chromatographyonline.com)
- To cite this document: BenchChem. [Technical Guide: Cross-Validation of L-Leucyl-L-alanine Quantification]. BenchChem, [2026]. [Online PDF]. Available at: [<https://www.benchchem.com/product/b1674815/docs#technical-guide-cross-validation-of-l-leucyl-l-alanine-quantification>]

Disclaimer & Data Validity:

The information provided in this document is for Research Use Only (RUO) and is strictly not intended for diagnostic or therapeutic procedures. While BenchChem strives to provide accurate protocols, we make no warranties, express or implied, regarding the fitness of this product for every specific experimental setup.

Technical Support: The protocols provided are for reference purposes. Unsure if this reagent suits your experiment?

Need Industrial/Bulk Grade? [Request Custom Synthesis Quote](#)

BenchChem

Our mission is to be the trusted global source of essential and advanced chemicals, empowering scientists and researchers to drive progress in science and industry.

Contact

Address: 3281 E Guasti Rd
Ontario, CA 91761, United States
Phone: (601) 213-4426
Email: info@benchchem.com

[Contact our Ph.D. Support Team for a compatibility check](#)

