

Pharmacological Activities of Fraxinellone: An In-depth Technical Guide

Author: BenchChem Technical Support Team. **Date:** December 2025

Compound of Interest

Compound Name: *Fraxinellone*

Cat. No.: *B1674054*

[Get Quote](#)

For Researchers, Scientists, and Drug Development Professionals

Introduction

Fraxinellone, a limonoid-type natural product isolated from the root bark of *Dictamnus dasycarpus*, has garnered significant attention in the scientific community for its diverse and potent pharmacological activities. This technical guide provides a comprehensive overview of the current state of research on **Fraxinellone**, focusing on its anti-inflammatory, anti-cancer, neuroprotective, cardioprotective, hepatoprotective, and insecticidal properties. Detailed experimental protocols, quantitative data, and visualizations of key signaling pathways are presented to facilitate further investigation and drug development efforts.

Anti-inflammatory Activity

Fraxinellone has demonstrated significant anti-inflammatory effects in various preclinical models, primarily through the modulation of key inflammatory pathways.

Quantitative Data: Anti-inflammatory Effects

Model	Parameter Measured	Fraxinellone Concentration/ Dose	Observed Effect	Reference
Human CD4+ T cells	IL-17 Production	40 µM	Suppression of IL-17 production	[1]
Collagen-Induced Arthritis (CIA) in mice	Arthritis Severity (clinical and histological)	7.5 mg/kg (injected)	Attenuation of clinical and histological features of inflammatory arthritis	
LPS-stimulated HaCaT cells	iNOS and COX-2 Production	Not specified	Inhibition of iNOS and COX-2 production	
LPS-stimulated HaCaT cells	IL-31, IL-31RA, TRPV1, TRPA1 Protein Levels	Not specified	Inhibition of protein levels	
2,4-dinitrofluorobenzene (DNFB)-induced atopic dermatitis-like mouse model	IL-31 Levels (serum and lesioned skin)	Not specified	Inhibition of IL-31 levels	

Experimental Protocol: Inhibition of IL-17 Production in Human T Cells

This protocol describes the in vitro assessment of **Fraxinellone's** effect on IL-17 production by human CD4+ T cells.

1. Cell Isolation and Culture:

- Isolate peripheral blood mononuclear cells (PBMCs) from healthy human donors using Ficoll-Paque density gradient centrifugation.

- Purify CD4+ T cells from PBMCs using magnetic-activated cell sorting (MACS) with CD4 microbeads.
- Culture the purified CD4+ T cells in RPMI-1640 medium supplemented with 10% fetal bovine serum (FBS), 100 U/mL penicillin, and 100 µg/mL streptomycin.

2. Th17 Differentiation:

- Induce Th17 differentiation by culturing the CD4+ T cells in the presence of anti-CD3 (plate-bound), anti-CD28, IL-6, IL-23, IL-1β, and anti-IFN-γ and anti-IL-4 neutralizing antibodies.

3. Fraxinellone Treatment:

- Treat the differentiating T cells with **Fraxinellone** (e.g., at a concentration of 40 µM) or vehicle control (DMSO).

4. Measurement of IL-17 Production:

- After a specified incubation period (e.g., 72 hours), collect the cell culture supernatants.
- Quantify the concentration of IL-17 in the supernatants using a human IL-17A ELISA kit according to the manufacturer's instructions.^{[2][3]}

5. Data Analysis:

- Compare the IL-17 concentrations in the **Fraxinellone**-treated group to the vehicle control group to determine the percentage of inhibition.

Signaling Pathway: Fraxinellone's Anti-inflammatory Mechanism

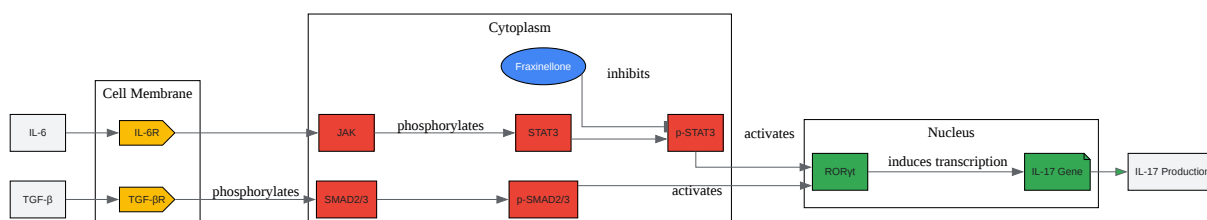

[Click to download full resolution via product page](#)

Caption: **Fraxinellone** inhibits IL-17 production by suppressing STAT3 phosphorylation.

Anti-cancer Activity

Fraxinellone exhibits potent anti-cancer activity by targeting multiple signaling pathways involved in cell proliferation, angiogenesis, and immune evasion.

Quantitative Data: Anti-cancer Effects

Cell Line	Cancer Type	Assay	Fraxinellone Concentration	IC50 Value	Reference
A549	Lung Adenocarcinoma	MTT Assay	Not specified	Not explicitly stated for Fraxinellone, but its inhibitory effect on proliferation is noted.[4]	
HOS	Osteosarcoma	CCK8 Assay	24 hours	78.3 μ M	
HOS	Osteosarcoma	CCK8 Assay	48 hours	72.1 μ M	
MG63	Osteosarcoma	CCK8 Assay	24 hours	62.9 μ M	
MG63	Osteosarcoma	CCK8 Assay	48 hours	45.3 μ M	

Experimental Protocol: MTT Assay for Cell Viability

This protocol details the use of an MTT assay to determine the cytotoxic effects of **Fraxinellone** on cancer cells (e.g., A549).[5]

1. Cell Seeding:

- Culture A549 cells in a 96-well plate at a density of 5×10^3 to 1×10^4 cells per well in 100 μ L of complete medium.
- Incubate overnight at 37°C in a humidified 5% CO₂ atmosphere to allow cell attachment.

2. Fraxinellone Treatment:

- Prepare a series of dilutions of **Fraxinellone** in culture medium.
- Replace the medium in the wells with 100 μ L of the **Fraxinellone** dilutions or vehicle control.
- Incubate for the desired time period (e.g., 24, 48, or 72 hours).

3. MTT Addition:

- Add 10 μ L of MTT solution (5 mg/mL in PBS) to each well.
- Incubate for 3-4 hours at 37°C until a purple formazan precipitate is visible.

4. Formazan Solubilization:

- Carefully remove the medium and add 100 μ L of DMSO to each well to dissolve the formazan crystals.
- Gently shake the plate for 5-10 minutes to ensure complete dissolution.

5. Absorbance Measurement:

- Measure the absorbance at 570 nm using a microplate reader.

6. Data Analysis:

- Calculate the percentage of cell viability for each concentration relative to the vehicle control.
- Determine the IC₅₀ value (the concentration of **Fraxinellone** that inhibits cell growth by 50%) by plotting a dose-response curve.

Signaling Pathway: Fraxinellone's Anti-cancer Mechanism

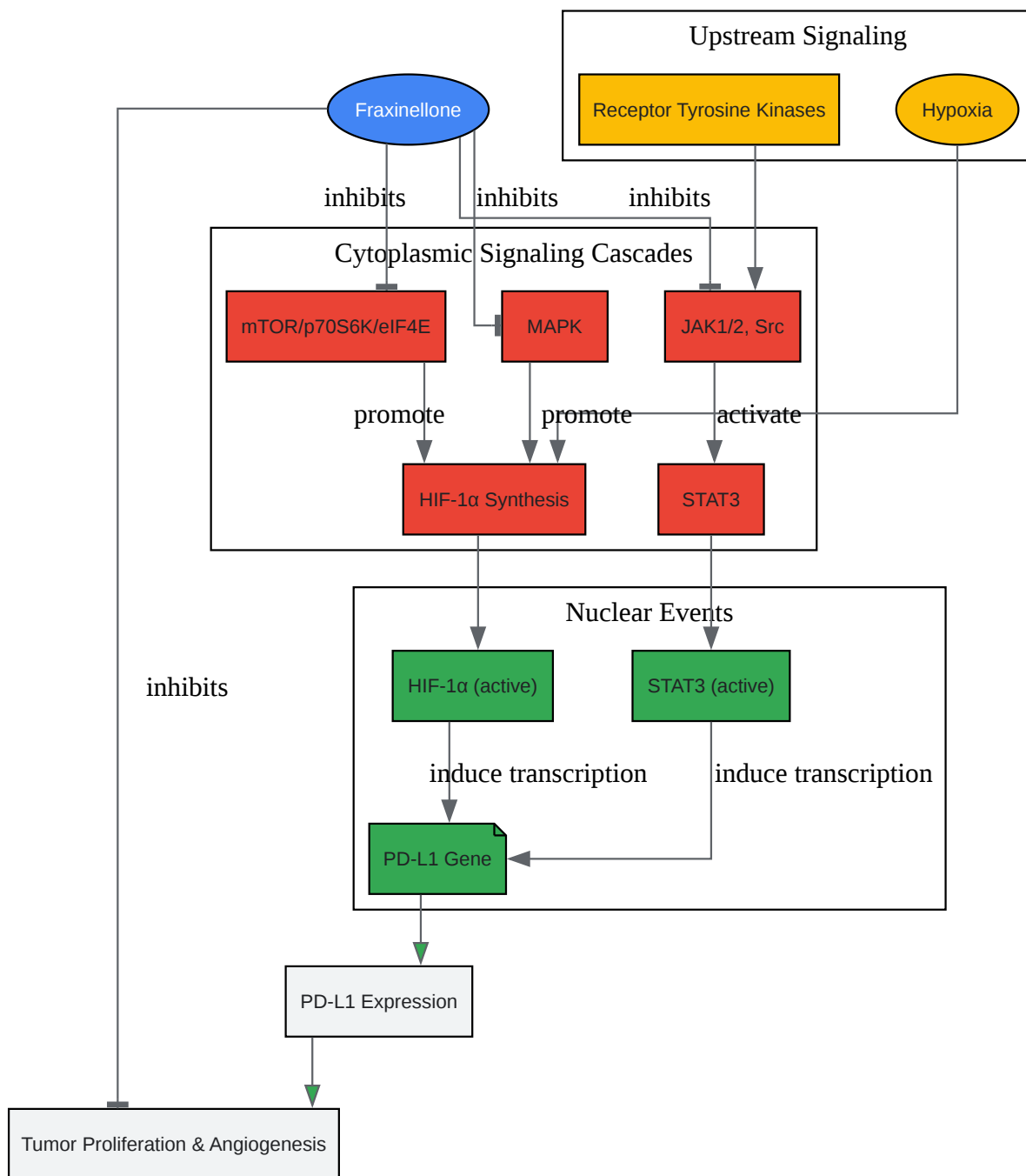

[Click to download full resolution via product page](#)

Caption: **Fraxinellone** inhibits cancer by downregulating STAT3 and HIF-1α pathways.[6]

Neuroprotective Activity

Fraxinellone and its analogs have shown promise in protecting neuronal cells from excitotoxicity and oxidative stress, key contributors to neurodegenerative diseases.

Quantitative Data: Neuroprotective Effects

Compound	Cell Line	Insult	Assay	EC50 Value	Reference
Fraxinellone Analog 2	PC12	Glutamate-mediated excitotoxicity	Cell Viability	44 nM	[1]
Fraxinellone Analog 2	SH-SY5Y	Glutamate-mediated excitotoxicity	Cell Viability	39 nM	[1]

Experimental Protocol: Glutamate-Induced Excitotoxicity Assay

This protocol describes an in vitro model to assess the neuroprotective effects of **Fraxinellone** against glutamate-induced neuronal cell death.[1]

1. Cell Culture:

- Culture neuronal cells (e.g., PC12 or SH-SY5Y) in appropriate medium in 96-well plates until they reach a desired confluency.

2. Pre-treatment with **Fraxinellone**:

- Treat the cells with various concentrations of **Fraxinellone** or its analogs for a specified period (e.g., 30 minutes).

3. Glutamate Exposure:

- After the pre-treatment period, wash the cells to remove the compound.
- Expose the cells to a neurotoxic concentration of glutamate (e.g., 100 μ M) for 24 hours.[1]

4. Cell Viability Assessment:

- Measure cell viability using a standard method such as the MTT assay or by quantifying ATP levels using a commercial kit (e.g., CellTiter-Glo).

5. Data Analysis:

- Calculate the percentage of cell viability relative to untreated control cells.
- Determine the EC50 value, which is the concentration of **Fraxinellone** that provides 50% protection against glutamate-induced cell death.

Signaling Pathway: Neuroprotective Mechanism of Fraxinellone Analog

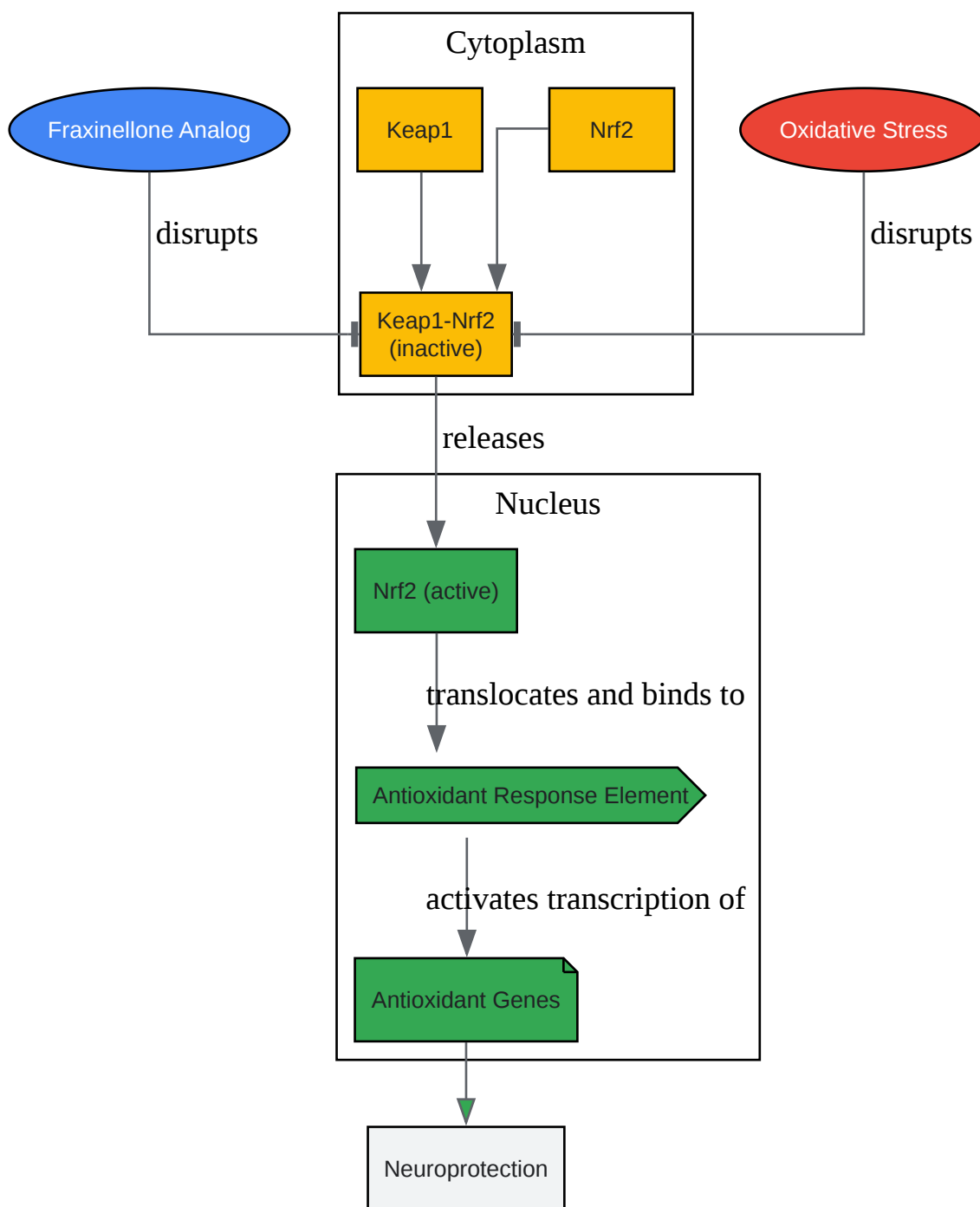

[Click to download full resolution via product page](#)

Caption: A **Fraxinellone** analog promotes neuroprotection via the Nrf2/Keap1 pathway.

Cardioprotective Activity

Fraxinellone has been shown to protect the heart from ischemia-reperfusion injury by reducing inflammation, oxidative stress, and apoptosis.

Quantitative Data: Cardioprotective Effects

Model	Parameter Measured	Fraxinellone Treatment	Observed Effect	Reference
Rat model of myocardial ischemia-reperfusion injury	Ventricular fibrillation (VF) induction rate	Pretreatment with Fraxinellone	Attenuation of VF induction rate	[7]
Rat model of myocardial ischemia-reperfusion injury	Myocardial fibrosis	Pretreatment with Fraxinellone	Amelioration of myocardial fibrosis	[7]

Experimental Workflow: In Vivo Cardioprotection Study

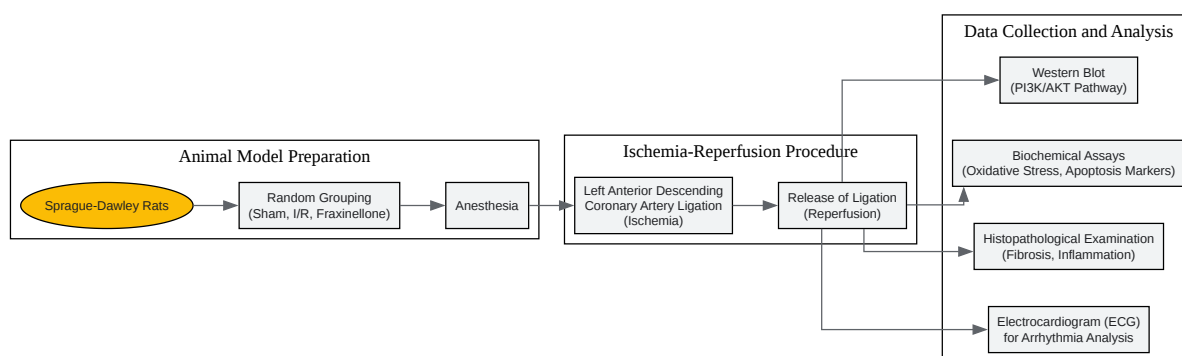

[Click to download full resolution via product page](#)

Caption: Workflow for assessing the cardioprotective effects of **Fraxinellone** in vivo.

Signaling Pathway: Proposed Cardioprotective Mechanism

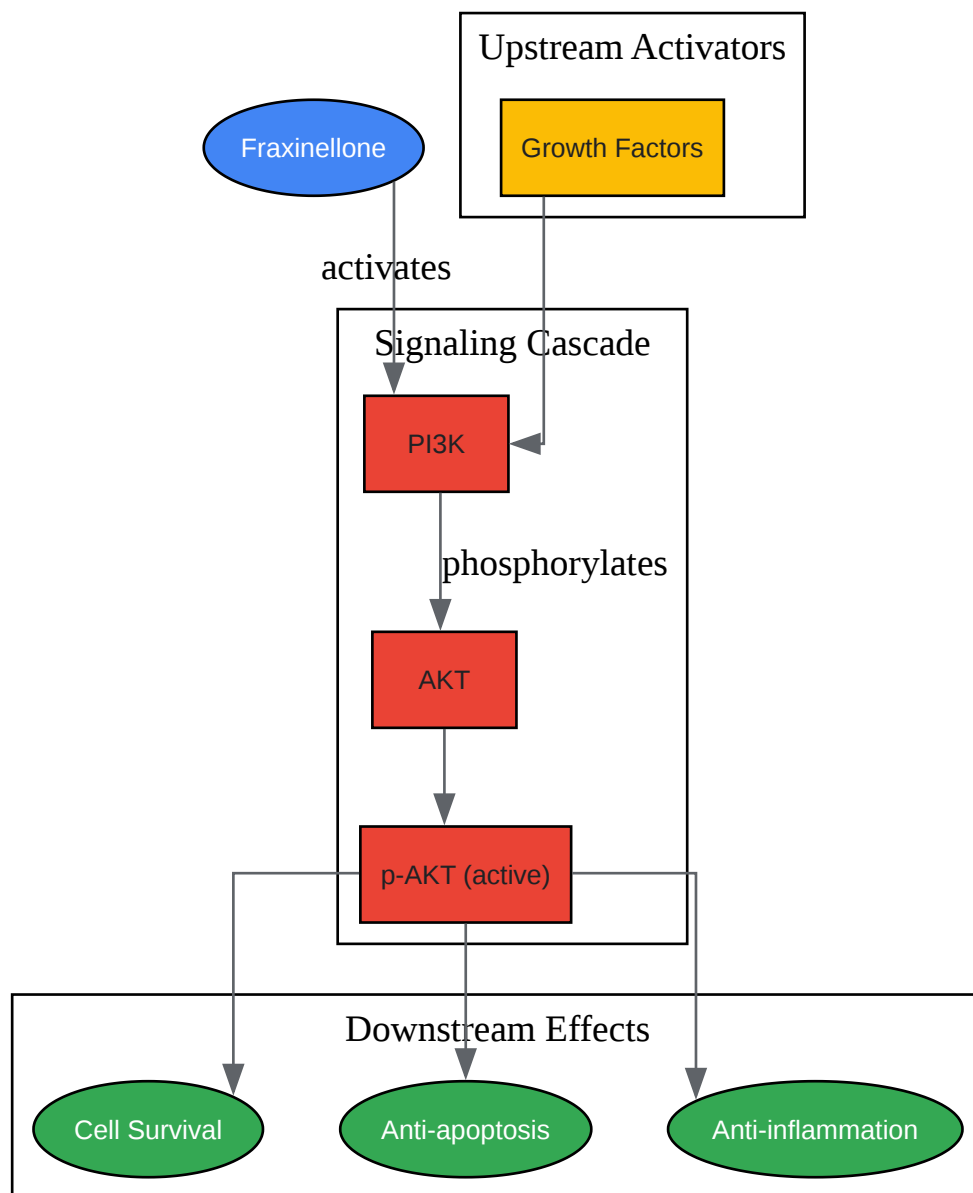

[Click to download full resolution via product page](#)

Caption: **Fraxinellone** may exert cardioprotective effects via the PI3K/AKT pathway.[7]

Hepatoprotective Activity

Fraxinellone has shown protective effects against liver injury in animal models.

Quantitative Data: Hepatoprotective Effects

Model	Parameter Measured	Fraxinellone Formulation	Observed Effect	Reference
CCI4-induced acute liver injury in mice	Alanine aminotransferase (ALT) enzyme activity increase	Fraxinellone in 20% HP-β-CD solution	59% inhibition	[8]
CCI4-induced acute liver injury in mice	Alanine aminotransferase (ALT) enzyme activity increase	Fraxinellone solution without HP-β-CD	20% inhibition	[8]
CCI4-induced liver injury in rats	Aspartate aminotransferase (AST) and Alanine aminotransferase (ALT) levels	Aqueous extract of Cortex Dictamni (containing Fraxinellone)	Significant prevention of CCI4-induced elevations	

Experimental Protocol: CCI4-Induced Hepatotoxicity Model

This protocol outlines the induction of acute liver injury in mice using carbon tetrachloride (CCI4) to evaluate the hepatoprotective effect of **Fraxinellone**.

1. Animal Model:

- Use male Kunming mice (or a similar strain).
- Acclimatize the animals for at least one week before the experiment.

2. Grouping and Treatment:

- Divide the mice into several groups: a normal control group, a CCl₄ model group, a positive control group (e.g., silymarin), and **Fraxinellone** treatment groups at different doses.
- Administer **Fraxinellone** (dissolved in a suitable vehicle, e.g., 20% HP- β -CD solution) or vehicle to the respective groups orally for a set period (e.g., 7 consecutive days).

3. Induction of Hepatotoxicity:

- On the last day of treatment, induce liver injury by intraperitoneal injection of a single dose of CCl₄ (e.g., 0.1% CCl₄ in olive oil).

4. Sample Collection:

- After a specific time post-CCl₄ injection (e.g., 24 hours), collect blood samples via retro-orbital puncture.
- Euthanize the animals and collect liver tissues.

5. Biochemical Analysis:

- Separate the serum from the blood samples.
- Measure the serum levels of liver injury markers, such as alanine aminotransferase (ALT) and aspartate aminotransferase (AST), using commercial assay kits.

6. Histopathological Examination:

- Fix the liver tissues in 10% neutral buffered formalin, embed in paraffin, section, and stain with hematoxylin and eosin (H&E) for microscopic evaluation of liver damage.

Insecticidal Activity

Fraxinellone exhibits significant insecticidal properties against various agricultural pests.

Quantitative Data: Insecticidal Effects

Pest Species	Larval Stage	Assay	LC50 Value	Reference
Mythimna separata (Oriental armyworm)	3rd instar	Larvicidal activity	15.95×10^{-2} mg/mL	
Plutella xylostella (Diamondback moth)	2nd instar	Larvicidal activity	6.43×10^{-2} mg/mL	
Culex pipiens pallens (Northern house mosquito)	4th instar	Larvicidal activity	3.60×10^{-2} mg/mL	
Mythimna separata	5th instar	Antifeedant activity (AFC50)	10.73 mg/mL	
Plutella xylostella	2nd instar	Antifeedant activity (AFC50)	7.93 mg/mL	
Agrotis ypsilon (Black cutworm)	2nd instar	Antifeedant activity (AFC50)	12.58 mg/mL	

Antiviral Activity

Currently, there is limited direct evidence in the public domain specifically detailing the antiviral activity of **Fraxinellone** against common human viruses such as influenza or herpes simplex virus. However, many natural products with anti-inflammatory and immunomodulatory properties, like **Fraxinellone**, are being investigated for their potential antiviral effects.[9][10][11][12][13][14][15][16][17][18][19] Further research is warranted to explore this pharmacological aspect of **Fraxinellone**.

Conclusion

Fraxinellone is a promising natural compound with a wide spectrum of pharmacological activities. Its demonstrated efficacy in preclinical models of inflammation, cancer, neurodegeneration, and cardiac and hepatic injury highlights its potential for the development of novel therapeutics. The detailed mechanisms of action, particularly the modulation of key

signaling pathways such as STAT3, HIF-1 α , and Nrf2, provide a solid foundation for targeted drug design and optimization. Further research, including comprehensive in vivo efficacy studies, pharmacokinetic and pharmacodynamic profiling, and safety assessments, is crucial to translate the therapeutic potential of **Fraxinellone** into clinical applications. The information compiled in this technical guide aims to serve as a valuable resource for researchers dedicated to advancing the field of natural product-based drug discovery.

Need Custom Synthesis?

BenchChem offers custom synthesis for rare earth carbides and specific isotopic labeling.

Email: info@benchchem.com or [Request Quote Online](#).

References

- 1. Fraxinellone protects against cardiac injury and decreases ventricular fibrillation susceptibility during myocardial ischemia-reperfusion - PubMed [pubmed.ncbi.nlm.nih.gov]
- 2. Human IL-17 ELISA - Quantikine D1700: R&D Systems [rndsystems.com]
- 3. biogot.com [biogot.com]
- 4. researchgate.net [researchgate.net]
- 5. MTT assay protocol | Abcam [abcam.com]
- 6. Hepatoprotective effects of blue honeysuckle on CCl₄-induced acute liver damaged mice - PMC [pmc.ncbi.nlm.nih.gov]
- 7. researchgate.net [researchgate.net]
- 8. mdpi.com [mdpi.com]
- 9. Cytotoxicity against A549 Human Lung Cancer Cell Line via the Mitochondrial Membrane Potential and Nuclear Condensation Effects of Nepeta paulesenii Briq., a Perennial Herb - PMC [pmc.ncbi.nlm.nih.gov]
- 10. researchgate.net [researchgate.net]
- 11. In vitro Cytotoxicity and Anti-herpes Simplex Virus Type 1 Activity of Hydroethanolic Extract, Fractions, and Isolated Compounds from Stem Bark of Schinus terebinthifolius Raddi - PMC [pmc.ncbi.nlm.nih.gov]
- 12. Compounds with anti-influenza activity: present and future of strategies for the optimal treatment and management of influenza Part II: Future compounds against influenza virus -

PMC [pmc.ncbi.nlm.nih.gov]

- 13. significant hepatoprotective activity: Topics by Science.gov [science.gov]
- 14. In vitro assessment of the cytotoxicity and anti-inflammatory properties of a novel dietary supplement - PMC [pmc.ncbi.nlm.nih.gov]
- 15. Screening and verification of antiviral compounds against HSV-1 using a method based on a plaque inhibition assay - PMC [pmc.ncbi.nlm.nih.gov]
- 16. Antiviral Activity of Isoimperatorin Against Influenza A Virus in vitro and its Inhibition of Neuraminidase - PMC [pmc.ncbi.nlm.nih.gov]
- 17. researchgate.net [researchgate.net]
- 18. mdpi.com [mdpi.com]
- 19. In vitro inhibition of herpes simplex virus type 1 replication by Mentha suaveolens essential oil and its main component piperitenone oxide - PubMed [pubmed.ncbi.nlm.nih.gov]
- To cite this document: BenchChem. [Pharmacological Activities of Fraxinellone: An In-depth Technical Guide]. BenchChem, [2025]. [Online PDF]. Available at: [https://www.benchchem.com/product/b1674054#pharmacological-activities-of-fraxinellone]

Disclaimer & Data Validity:

The information provided in this document is for Research Use Only (RUO) and is strictly not intended for diagnostic or therapeutic procedures. While BenchChem strives to provide accurate protocols, we make no warranties, express or implied, regarding the fitness of this product for every specific experimental setup.

Technical Support: The protocols provided are for reference purposes. Unsure if this reagent suits your experiment? [[Contact our Ph.D. Support Team for a compatibility check](#)]

Need Industrial/Bulk Grade? [Request Custom Synthesis Quote](#)

BenchChem

Our mission is to be the trusted global source of essential and advanced chemicals, empowering scientists and researchers to drive progress in science and industry.

Contact

Address: 3281 E Guasti Rd

Ontario, CA 91761, United States

Phone: (601) 213-4426

Email: info@benchchem.com