

# In Vitro Profile of ICI D1542 (ZD1542): A Dual-Action Thromboxane Modulator

**Author:** BenchChem Technical Support Team. **Date:** December 2025

## Compound of Interest

Compound Name: ICI D1542

Cat. No.: B1674353

[Get Quote](#)

An in-depth analysis of the preclinical in vitro data for **ICI D1542** (also known as ZD1542), a potent molecule with a dual mechanism of action targeting the thromboxane A2 pathway. This technical guide provides a comprehensive overview of its inhibitory and antagonistic activities, supported by quantitative data, detailed experimental protocols, and visual representations of its mechanism and experimental workflows.

## Quantitative In Vitro Pharmacology Data

The following tables summarize the key quantitative data from in vitro studies of **ICI D1542**, demonstrating its potency as both a thromboxane A2 synthase inhibitor and a thromboxane A2 receptor antagonist.

Table 1: Thromboxane A2 Synthase Inhibition

Species	Preparation	Parameter	Value ( $\mu\text{M}$ )
Human	Platelet Microsomes	IC50 (TXB2 production)	0.016
Human	Whole Blood	IC50 (Collagen-stimulated TXS)	0.018
Rat	Whole Blood	IC50 (Collagen-stimulated TXS)	0.009
Dog	Whole Blood	IC50 (Collagen-stimulated TXS)	0.049

Table 2: Thromboxane A2 (TP) Receptor Antagonism

Species	Preparation	Agonist	Parameter	Value (pA2)
Human	Platelets	U46619	Apparent pA2	8.3
Rat	Platelets	U46619	Apparent pA2	8.5
Dog	Platelets	U46619	Apparent pA2	9.1
Rat	Thoracic Aorta	U46619	Apparent pA2	8.6
Guinea-Pig	Trachea	U46619	Apparent pA2	8.3
Guinea-Pig	Lung Parenchyma	U46619	Apparent pA2	8.5

Table 3: Selectivity Profile

Target	Preparation	Parameter	Value (µM)
Cyclo-oxygenase	Human Umbilical Vein Endothelial Cells (HUVEC)	IC50	> 100
Prostacyclin (PGI2) Synthase	Human Umbilical Vein Endothelial Cells (HUVEC)	IC50	18.0 +/- 8.6

## Experimental Protocols

The following are detailed methodologies for the key in vitro experiments cited in the evaluation of **ICI D1542**.

### Thromboxane A2 Synthase Activity Assay

This assay determines the inhibitory activity of **ICI D1542** on thromboxane A2 synthase.

- Preparation of Platelet Microsomes: Human platelets are isolated and subjected to microsomal preparation to enrich for thromboxane A2 synthase.
- Incubation: The platelet microsomal preparation is incubated with **ICI D1542** at varying concentrations.
- Measurement of TXB2 Production: The production of thromboxane B2 (TXB2), a stable metabolite of thromboxane A2, is measured. This is quantified to determine the extent of enzyme inhibition.
- Data Analysis: The concentration of **ICI D1542** that inhibits TXB2 production by 50% (IC50) is calculated.<sup>[1]</sup>

### Whole Blood Thromboxane Synthesis Assay

This assay assesses the effect of **ICI D1542** on thromboxane synthesis in a more physiologically relevant whole blood environment.

- Blood Collection: Whole blood is collected from human, rat, and dog subjects.

- Stimulation: Collagen is used to stimulate thromboxane synthesis in the whole blood samples.
- Incubation with **ICI D1542**: The blood samples are incubated with a range of concentrations of **ICI D1542**.
- Measurement of Prostanoids: The levels of TXB2, as well as prostaglandins PGD2, PGE2, and PGF2 $\alpha$ , are measured to assess the inhibition of thromboxane synthase and any potential shunting of the metabolic pathway.
- Data Analysis: The IC50 value for the inhibition of collagen-stimulated TXB2 formation is determined.[1]

## Platelet Aggregation Assay

This assay evaluates the antagonistic effect of **ICI D1542** on the thromboxane A2 receptor (TP receptor) in platelets.

- Platelet Preparation: Platelet-rich plasma is prepared from human, rat, and dog blood.
- Incubation: The platelets are incubated with various concentrations of **ICI D1542**.
- Induction of Aggregation: The synthetic thromboxane A2 mimetic, U46619, is added to induce platelet aggregation.
- Measurement of Aggregation: Platelet aggregation is monitored and measured.
- Data Analysis: The apparent pA2 values are calculated to quantify the antagonist potency of **ICI D1542**. [1]

## Smooth Muscle Contraction Assay

This assay investigates the antagonist activity of **ICI D1542** on TP receptors in vascular and pulmonary smooth muscle.

- Tissue Preparation: Preparations of rat thoracic aorta, guinea-pig trachea, and lung parenchyma are used.

- Incubation: The smooth muscle preparations are incubated with **ICI D1542** at different concentrations.
- Induction of Contraction: U46619 is used to induce smooth muscle contraction.
- Measurement of Contraction: The contractile responses of the smooth muscle preparations are measured.
- Data Analysis: Apparent pA2 values are determined to assess the antagonist potency of **ICI D1542** in these tissues. The study also evaluated the effect of **ICI D1542** on contractions induced by non-prostanoid agonists to assess its selectivity.[1]

## Visualizing the Mechanism and Workflows

### Signaling Pathway of ICI D1542

The following diagram illustrates the dual mechanism of action of **ICI D1542** within the arachidonic acid cascade.

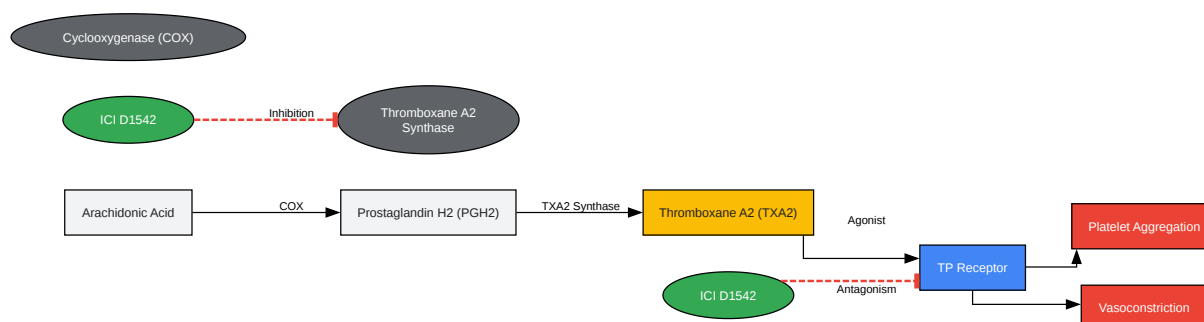

[Click to download full resolution via product page](#)

Caption: Dual mechanism of **ICI D1542** in the thromboxane A2 pathway.

## Experimental Workflow for In Vitro Evaluation

The diagram below outlines the general workflow for the in vitro characterization of **ICI D1542**.

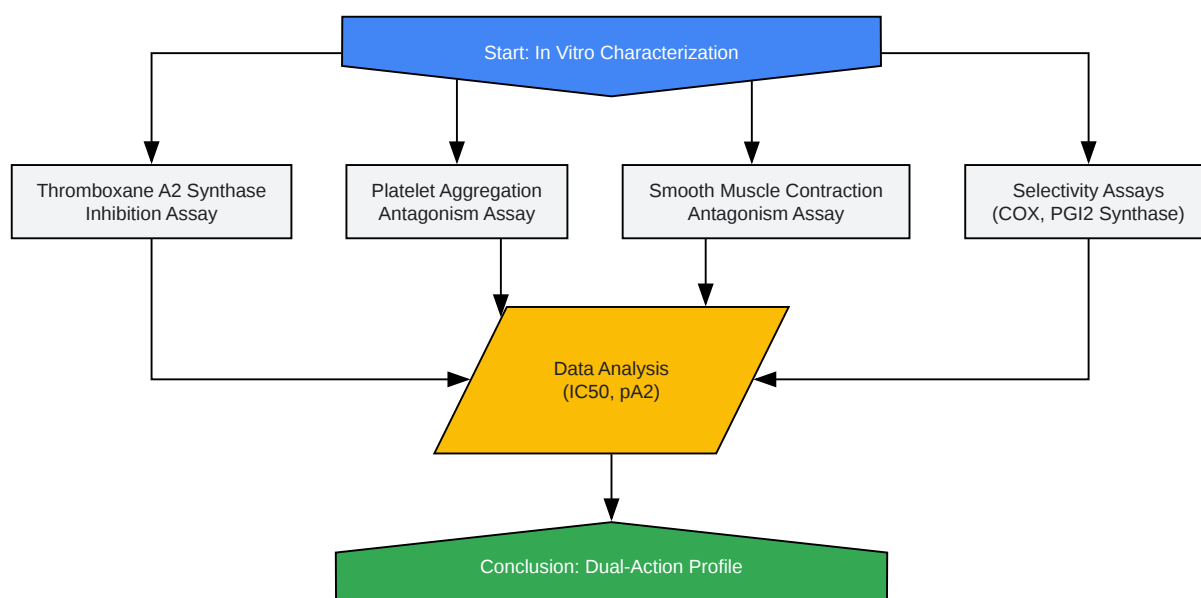

[Click to download full resolution via product page](#)

Caption: General workflow for the in vitro evaluation of **ICI D1542**.

### Need Custom Synthesis?

BenchChem offers custom synthesis for rare earth carbides and specific isotopic labeling.

Email: [info@benchchem.com](mailto:info@benchchem.com) or [Request Quote Online](#).

## References

- 1. ZD1542, a potent thromboxane A2 synthase inhibitor and receptor antagonist in vitro - PubMed [pubmed.ncbi.nlm.nih.gov]

- To cite this document: BenchChem. [In Vitro Profile of ICI D1542 (ZD1542): A Dual-Action Thromboxane Modulator]. BenchChem, [2025]. [Online PDF]. Available at: [<https://www.benchchem.com/product/b1674353#ici-d1542-in-vitro-studies>]

---

### Disclaimer & Data Validity:

The information provided in this document is for Research Use Only (RUO) and is strictly not intended for diagnostic or therapeutic procedures. While BenchChem strives to provide accurate protocols, we make no warranties, express or implied, regarding the fitness of this product for every specific experimental setup.

**Technical Support:** The protocols provided are for reference purposes. Unsure if this reagent suits your experiment? [[Contact our Ph.D. Support Team for a compatibility check](#)]

**Need Industrial/Bulk Grade?** [Request Custom Synthesis Quote](#)

## BenchChem

Our mission is to be the trusted global source of essential and advanced chemicals, empowering scientists and researchers to drive progress in science and industry.

### Contact

Address: 3281 E Guasti Rd  
Ontario, CA 91761, United States  
Phone: (601) 213-4426  
Email: [info@benchchem.com](mailto:info@benchchem.com)