

In Vitro Assays for Testing Neuropeptide Activity: Application Notes and Protocols

Author: BenchChem Technical Support Team. **Date:** May 2026

Compound of Interest

Compound Name: *Pentapeptide-18*

CAS No.: *64963-01-5*

Cat. No.: *B1674835*

[Get Quote](#)

For Researchers, Scientists, and Drug Development Professionals

This document provides detailed application notes and protocols for a range of in vitro assays essential for characterizing the activity of neuropeptides. These assays are fundamental tools in neuroscience research and drug discovery, enabling the quantification of neuropeptide release, receptor binding, and downstream signaling events.

Neuropeptide Release Assays

Neuropeptide release from neurons is a critical step in their signaling function. Unlike classical neurotransmitters, neuropeptides are stored in dense-core vesicles (DCVs) and released in response to sustained neuronal activity.^[1] Several in vitro methods have been developed to quantify neuropeptide release, moving from lower-throughput, labor-intensive techniques to more sensitive and high-throughput approaches.

Traditional Methods: ELISA and Mass Spectrometry

Enzyme-linked immunosorbent assays (ELISAs) and mass spectrometry (MS) can be used to detect the release of endogenous neuropeptides.^[1] However, these methods often require

large cell samples and lack high temporal resolution.[1]

Genetically-Encoded Reporter Assays

More advanced methods utilize genetically-encoded reporters to monitor neuropeptide release with high sensitivity and spatiotemporal resolution. These reporters are typically fusion proteins consisting of a neuropeptide and a fluorescent or luminescent protein.

A high-throughput assay for DCV exocytosis has been developed using a chimera of Nanoluc luciferase and a DCV-cargo neuropeptide, such as Neuropeptide Y (NPY).[1] This NPY-Nanoluc reporter is targeted to DCVs and released in a calcium-dependent manner upon neuronal depolarization.[1] The amount of released reporter can be quantified by measuring the luminescence of the culture medium.[1] This assay is highly sensitive, suitable for pharmacological and genomic screening, and can be used in both rodent and human neurons.[1]

Another approach involves fusing a pH-sensitive fluorescent protein, like super-ecliptic pHluorin, to a neuropeptide.[1] The fluorescence of pHluorin is quenched in the acidic environment of the DCV and increases upon exocytosis and exposure to the neutral pH of the extracellular space.[2] This method allows for the detection of single DCV fusion events with high temporal resolution.[1]

Receptor Binding Assays

Receptor binding assays are crucial for determining the affinity of neuropeptides and other ligands for their cognate receptors.[3] These assays typically use cell membranes prepared from cells overexpressing the receptor of interest.

Radioligand Binding Assay

This is a classic and highly sensitive method to measure ligand-receptor interactions.[3] It involves the use of a radiolabeled ligand that binds to the receptor.

Protocol: Competitive Radioligand Binding Assay for Neuropeptide Y (NPY) Y2 Receptor[3]

Materials and Reagents:[3]

- Cell Line: Human cell line stably expressing the NPY Y2 receptor (e.g., HEK293 cells).

- Radioligand: [¹²⁵I]-Peptide YY.
- Unlabeled Ligand (Competitor): Neuropeptide Y (13-36) or test compounds.
- Lysis Buffer: 50 mM Tris-HCl, 5 mM MgCl₂, 5 mM EDTA, pH 7.4, with protease inhibitors.
- Assay Buffer: 50 mM Tris-HCl, 5 mM MgCl₂, 0.1% Bovine Serum Albumin (BSA), pH 7.7.
- Wash Buffer: Ice-cold 50 mM NaCl, pH 7.4.
- Scintillation Cocktail.

Procedure:[\[3\]](#)

- Membrane Preparation:
 - Culture cells expressing the NPY Y2 receptor to high density.
 - Harvest cells, wash with ice-cold PBS, and pellet by centrifugation.
 - Resuspend the cell pellet in ice-cold lysis buffer and homogenize.
 - Centrifuge the homogenate at low speed (1,000 x g) to remove nuclei and intact cells.
 - Centrifuge the supernatant at high speed (40,000 x g) to pellet the cell membranes.
 - Resuspend the membrane pellet in assay buffer and determine the protein concentration.
- Binding Assay:
 - In a microplate, combine the cell membranes, radioligand ([¹²⁵I]-Peptide YY), and varying concentrations of the unlabeled competitor ligand (e.g., NPY (13-36)).
 - For total binding, omit the competitor. For non-specific binding, add a high concentration of unlabeled NPY (e.g., 1 μM).
 - Incubate the plate to allow the binding to reach equilibrium.
- Separation and Detection:

- Rapidly filter the reaction mixture through a glass fiber filter to separate bound from free radioligand.
- Wash the filters multiple times with ice-cold wash buffer.
- Place the filters in scintillation vials, add scintillation cocktail, and measure the radioactivity using a gamma counter.

Data Analysis:[3]

- Calculate specific binding by subtracting non-specific binding from total binding.
- Plot the percentage of specific binding against the logarithm of the competitor concentration to generate a competition curve.
- Determine the IC₅₀ (concentration of competitor that inhibits 50% of specific radioligand binding) and subsequently the K_i (inhibition constant) of the test compound.

Fluorescence-Based Binding Assays

To avoid the drawbacks of radioactivity, fluorescence-based assays have been developed.[4] These assays utilize fluorescently labeled ligands and allow for homogeneous measurements without the need for separation steps.[4][5]

Quantitative Data Summary: Receptor Binding Affinities

Neuropeptide Ligand	Receptor	Assay Type	Ki/Kd (nM)	Reference
[³ H]UR-MK299	NPY Y1 Receptor	Radioligand Competition	0.054 (Kd)	[4]
[³ H]propionyl-pNPY	NPY Y2 Receptor	Radioligand Competition	0.14 (Kd)	[4]
[³ H]UR-KK200	NPY Y4 Receptor	Radioligand Competition	0.67 (Kd)	[4]
Fluorescent Cyclic Peptide	NPY Y4 Receptor	Fluorescence-based	9.02 - 9.9 (pKd)	[5]

Second Messenger Assays

Many neuropeptide receptors are G protein-coupled receptors (GPCRs) that, upon activation, trigger changes in intracellular second messenger concentrations, such as cyclic AMP (cAMP) and calcium (Ca²⁺).[6][7]

cAMP Assays

Neuropeptide receptors coupled to G_s or G_i proteins modulate the activity of adenylyl cyclase, leading to an increase or decrease in intracellular cAMP levels, respectively.[8]

Protocol: AlphaScreen cAMP Assay[9]

This is a competitive immunoassay that measures cAMP levels in whole cells.[9]

Principle: The assay is based on the competition between endogenous cAMP produced by the cells and an exogenously added biotin-cAMP for binding to an anti-cAMP antibody conjugated to acceptor beads.[9]

Materials and Reagents:[9]

- Cells expressing the GPCR of interest.
- Stimulation buffer.

- Test compounds (agonists or antagonists).
- AlphaScreen cAMP Assay Kit (containing biotin-cAMP, anti-cAMP acceptor beads, and streptavidin donor beads).

Procedure:[\[9\]](#)

- Cell Preparation:
 - Harvest cells and resuspend them in stimulation buffer to the desired concentration.[\[10\]](#)
 - For adherent cells, seed them in a microplate and incubate overnight.[\[10\]](#)
- Agonist Assay:
 - Add test compounds at various concentrations to the cells.
 - Incubate to stimulate cAMP production.
- Antagonist Assay:
 - Pre-incubate cells with the antagonist.
 - Add a known agonist at a concentration that elicits a submaximal response (e.g., EC80).
 - Incubate to stimulate cAMP production.
- Lysis and Detection:
 - Lyse the cells and add the detection reagents (biotin-cAMP and acceptor beads).
 - Incubate to allow for competition.
 - Add streptavidin donor beads and incubate.
 - Read the signal on an AlphaScreen-compatible plate reader.

Data Analysis:

- A decrease in the AlphaScreen signal indicates an increase in intracellular cAMP.
- Generate dose-response curves to determine the EC50 for agonists or the IC50 for antagonists.

Calcium Mobilization Assays

Neuropeptide receptors coupled to Gq proteins activate phospholipase C, leading to the release of Ca²⁺ from intracellular stores.[11] This transient increase in intracellular Ca²⁺ can be measured using fluorescent calcium indicators.[7]

Protocol: Fluorescence-Based Calcium Mobilization Assay[7][11]

Materials and Reagents:

- HEK293T cells.
- Expression plasmids for the GPCR of interest and a promiscuous Gα protein (e.g., Gα16).[7]
- Transfection reagent.
- Fluorescent calcium indicator dye (e.g., Fluo-4 AM).[7]
- Assay buffer.
- Test compounds.

Procedure:[7]

- Cell Transfection:
 - Co-transfect HEK293T cells with the plasmids for the GPCR and Gα16.
 - Seed the transfected cells into a microplate.
- Dye Loading:
 - Incubate the cells with the Fluo-4 AM dye to allow it to enter the cells and be cleaved to its active form.

- Assay:
 - Place the plate in a fluorescence imaging plate reader (FLIPR) or a similar instrument that allows for simultaneous compound addition and fluorescence measurement.[7]
 - Add the test compounds and immediately measure the change in fluorescence intensity over time.

Data Analysis:[7]

- The increase in fluorescence intensity corresponds to the increase in intracellular Ca^{2+} .
- Determine the peak fluorescence response for each concentration of the test compound.
- Generate dose-response curves to determine the EC50 of agonists.

Quantitative Data Summary: Functional Assays

Neuropeptide	Receptor	Assay Type	EC50 (nM)	Reference
Neuropeptide S (NPS)	NPSR	Calcium Mobilization	~1	[6][12]
Neuropeptide Y (NPY)	NPY Y5 Receptor	Reporter Gene (GFP)	Dose-dependent expression	[13]

Reporter Gene Assays

Reporter gene assays provide a method to measure receptor activation by linking it to the expression of a readily detectable protein.[13]

Principle: A reporter gene (e.g., luciferase or green fluorescent protein (GFP)) is placed under the control of a response element that is activated by the signaling pathway downstream of the neuropeptide receptor.[13] For example, for a G_i -coupled receptor that decreases cAMP, the reporter can be controlled by a cAMP response element (CRE).[13]

Protocol: CRE-GFP Reporter Gene Assay for a G_i -Coupled Receptor[13]

Materials and Reagents:

- Host cell line (e.g., CHO cells).
- Expression plasmid for the Gi-coupled neuropeptide receptor.
- Reporter plasmid containing a CRE-driven GFP gene.
- Transfection reagent.
- Test compounds.

Procedure:[\[13\]](#)

- Cell Transfection:
 - Co-transfect the host cells with the receptor and reporter plasmids.
- Stimulation:
 - Treat the transfected cells with the neuropeptide agonist.
 - To measure the inhibition of adenylyl cyclase, cells can be co-stimulated with forskolin (an activator of adenylyl cyclase).
- Detection:
 - After an appropriate incubation period to allow for gene expression, measure the GFP fluorescence using a fluorescence microscope or plate reader.

Data Analysis:[\[13\]](#)

- An increase in GFP expression in response to the agonist (in the presence of forskolin for a Gi-coupled receptor) indicates receptor activation.
- Generate dose-response curves to determine the potency of the agonist.

Visualizations

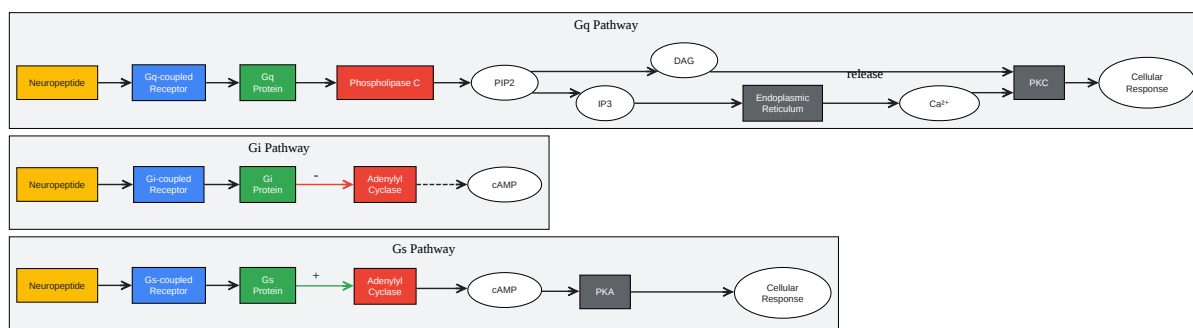

[Click to download full resolution via product page](#)

Caption: Major GPCR signaling pathways activated by neuropeptides.

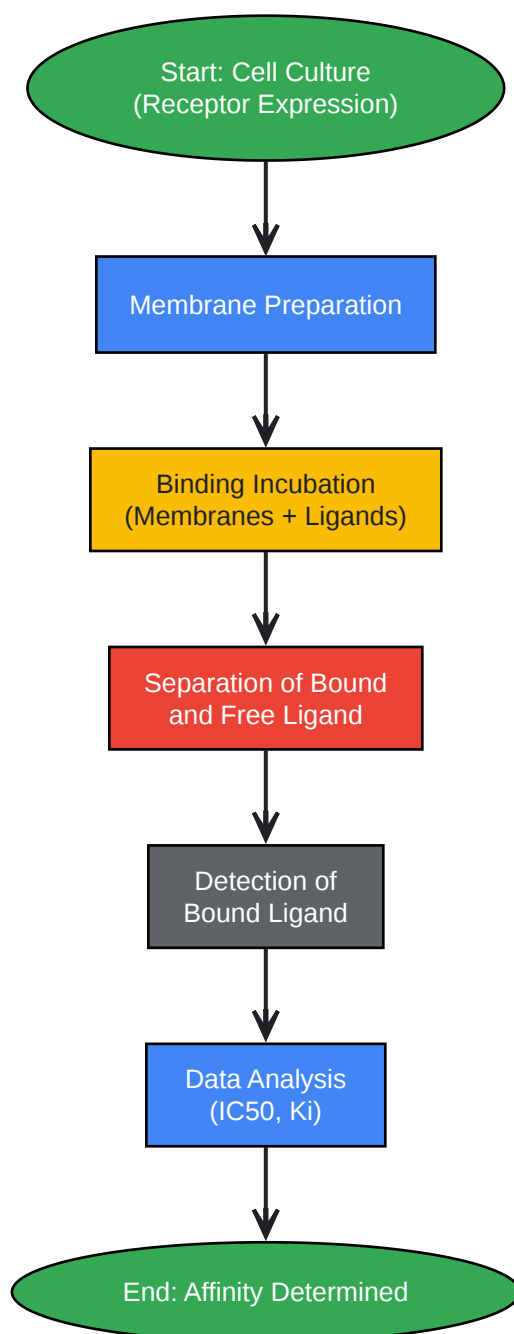

[Click to download full resolution via product page](#)

Caption: Workflow for a competitive radioligand binding assay.

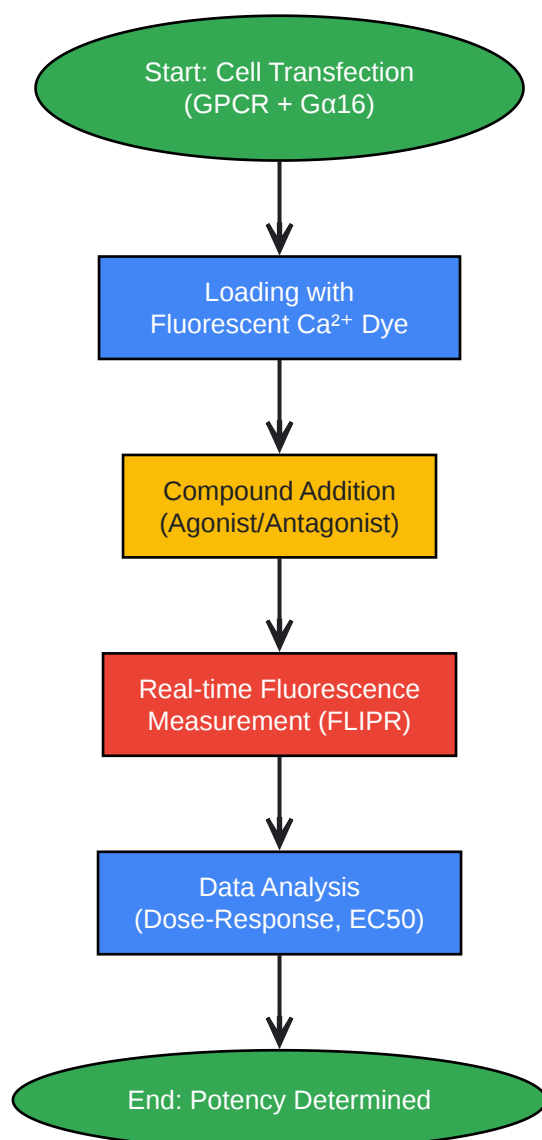

[Click to download full resolution via product page](#)

Caption: Workflow for a fluorescence-based calcium mobilization assay.

Need Custom Synthesis?

BenchChem offers custom synthesis for rare earth carbides and specific isotopic labeling.

Email: info@benchchem.com or [Request Quote Online](#).

References

- 1. High-throughput assay for regulated secretion of neuropeptides in mouse and human neurons - PMC [[pmc.ncbi.nlm.nih.gov](https://pubmed.ncbi.nlm.nih.gov)]
- 2. Imaging neuropeptide release at synapses with a genetically engineered reporter - PMC [[pmc.ncbi.nlm.nih.gov](https://pubmed.ncbi.nlm.nih.gov)]
- 3. [benchchem.com](https://www.benchchem.com) [[benchchem.com](https://www.benchchem.com)]
- 4. pubs.acs.org [pubs.acs.org]
- 5. Illuminating Neuropeptide Y Y4 Receptor Binding: Fluorescent Cyclic Peptides with Subnanomolar Binding Affinity as Novel Molecular Tools - PMC [[pmc.ncbi.nlm.nih.gov](https://pubmed.ncbi.nlm.nih.gov)]
- 6. A Multiplex Calcium Assay for Identification of GPCR Agonists and Antagonists - PMC [[pmc.ncbi.nlm.nih.gov](https://pubmed.ncbi.nlm.nih.gov)]
- 7. Characterization of G Protein-coupled Receptors by a Fluorescence-based Calcium Mobilization Assay - PMC [[pmc.ncbi.nlm.nih.gov](https://pubmed.ncbi.nlm.nih.gov)]
- 8. [dda.creative-bioarray.com](https://www.dda.creative-bioarray.com) [[dda.creative-bioarray.com](https://www.dda.creative-bioarray.com)]
- 9. resources.revvity.com [resources.revvity.com]
- 10. Cell preparation: a key step for successful cAMP assays. | Revvity [[revvity.com](https://www.revvity.com)]
- 11. [dda.creative-bioarray.com](https://www.dda.creative-bioarray.com) [[dda.creative-bioarray.com](https://www.dda.creative-bioarray.com)]
- 12. [research.unipd.it](https://www.research.unipd.it) [[research.unipd.it](https://www.research.unipd.it)]
- 13. The first reporter gene assay on living cells: green fluorescent protein as reporter gene for the investigation of Gi-protein coupled receptors - PubMed [pubmed.ncbi.nlm.nih.gov]
- To cite this document: BenchChem. [In Vitro Assays for Testing Neuropeptide Activity: Application Notes and Protocols]. BenchChem, [2026]. [Online PDF]. Available at: [<https://www.benchchem.com/product/b1674835/docs#in-vitro-assays-for-testing-neuropeptide-activity-application-notes-and-protocols>]

Disclaimer & Data Validity:

The information provided in this document is for Research Use Only (RUO) and is strictly not intended for diagnostic or therapeutic procedures. While BenchChem strives to provide accurate protocols, we make no warranties, express or implied, regarding the fitness of this product for every specific experimental setup.

Technical Support: The protocols provided are for reference purposes. Unsure if this reagent suits your experiment?

Need Industrial/Bulk Grade? [Request Custom Synthesis Quote](#)

BenchChem

Our mission is to be the trusted global source of essential and advanced chemicals, empowering scientists and researchers to drive progress in science and industry.

Contact

Address: 3281 E Guasti Rd
Ontario, CA 91761, United States
Phone: (601) 213-4426
Email: info@benchchem.com

[Contact our Ph.D. Support Team for a compatibility check](#)