

# The Core Mechanism of CDZ173 (Leniolisib): A Technical Guide

**Author:** BenchChem Technical Support Team. **Date:** April 2026

## Compound of Interest

Compound Name: HW 173  
CAS No.: 110270-70-7  
Cat. No.: B1673424

[Get Quote](#)

For Researchers, Scientists, and Drug Development Professionals

## Abstract

CDZ173, also known as leniolisib, is a potent and highly selective small-molecule inhibitor of the phosphoinositide 3-kinase  $\delta$  (PI3K $\delta$ ) isoform.<sup>[1][2][3]</sup> Its targeted mechanism of action has positioned it as a first-in-class therapeutic for Activated PI3K $\delta$  Syndrome (APDS), a rare primary immunodeficiency.<sup>[4][5][6]</sup> This document provides an in-depth technical overview of the mechanism of action of CDZ173, detailing its molecular interactions, downstream signaling effects, and the experimental basis for these findings.

## Introduction to PI3K $\delta$ and its Role in Immunity

Phosphoinositide 3-kinases (PI3Ks) are a family of lipid kinases that play crucial roles in various cellular processes, including cell growth, proliferation, survival, and differentiation.<sup>[2]</sup> The class I PI3Ks are heterodimers composed of a catalytic subunit (p110) and a regulatory subunit (p85).<sup>[1][7]</sup> The PI3K $\delta$  isoform, encoded by the PIK3CD gene, is predominantly expressed in hematopoietic cells and is critical for the proper function of both innate and adaptive immunity.<sup>[1][2]</sup>

PI3K $\delta$  is activated downstream of various cell surface receptors, including B-cell receptors (BCRs), T-cell receptors (TCRs), and some G protein-coupled receptors (GPCRs).[1][7] Upon activation, PI3K $\delta$  phosphorylates phosphatidylinositol 4,5-bisphosphate (PIP2) to generate the second messenger phosphatidylinositol 3,4,5-trisphosphate (PIP3).[1] PIP3 recruits and activates downstream effectors, most notably the serine/threonine kinase AKT, which in turn modulates a cascade of signaling pathways, including the mTOR pathway, to regulate immune cell function.[2][7][8]

In APDS, gain-of-function mutations in PIK3CD or loss-of-function mutations in PIK3R1 (encoding the p85 $\alpha$  regulatory subunit) lead to hyperactivation of the PI3K $\delta$  pathway.[9][10] This results in immune dysregulation characterized by lymphoproliferation, immunodeficiency, and an increased risk of lymphoma.[9]

## Molecular Mechanism of Action of CDZ173

CDZ173 is an orally bioavailable, potent, and selective inhibitor of PI3K $\delta$ . [1][11] It exerts its therapeutic effect by directly targeting the catalytic p110 $\delta$  subunit, thereby normalizing the hyperactive signaling cascade in immune cells.[7][9]

## Binding to the ATP Site of PI3K $\delta$

Crystallographic studies have revealed that CDZ173 binds to the ATP-binding site of the p110 $\delta$  catalytic subunit.[1] This binding is characterized by the stacking of the propionamide group of CDZ173 with the tryptophan residue W760 of PI3K $\delta$ . [1] This interaction is crucial for its high potency and selectivity for the  $\delta$  isoform. The binding mode of CDZ173 is distinct from that of first-generation PI3K $\delta$  inhibitors.[1]

## Inhibition of Downstream Signaling

By occupying the ATP-binding pocket, CDZ173 prevents the phosphorylation of PIP2 to PIP3. [1] This reduction in PIP3 levels leads to decreased activation of the downstream kinase AKT. [7][12] Consequently, the entire PI3K/AKT/mTOR signaling pathway is downregulated.[2] This has been demonstrated by the dose-dependent suppression of AKT and S6 phosphorylation in both cell lines expressing APDS-mutant p110 $\delta$  and in primary T-cell blasts derived from patients with APDS.[9][13]

## Quantitative Data on CDZ173 Activity

The potency and selectivity of CDZ173 have been characterized in a variety of in vitro and in vivo assays.

Assay Type	Target/System	Metric	Value	Reference
Cell-free enzyme assay	PI3K $\delta$	IC50	11 nM	[10]
Cell-free enzyme assay	PI3K $\alpha$	Selectivity vs PI3K $\delta$	22-fold	[10]
Cell-free enzyme assay	PI3K $\beta$	Selectivity vs PI3K $\delta$	38-fold	[10]
Cell-free enzyme assay	PI3K $\gamma$	Selectivity vs PI3K $\delta$	202-fold	[10]
Cellular Assay (Rat-1 cells)	PI3K $\alpha$ (pAKT readout)	Selectivity vs PI3K $\delta$	30-fold	[1]
Cellular Assay (U937 monocytes)	PI3K $\gamma$ (MIP-1 $\alpha$ induced activation)	IC50	> 7.4 $\mu$ M	[1]
In vitro B-cell inhibition	Human, macaque, rat, mouse	IC50	7 nM - 0.2 $\mu$ M	[8]
In vitro T-cell inhibition	Human, macaque, rat, mouse	IC50	7 nM - 0.2 $\mu$ M	[8]
Ex vivo B-cell activation (pAKT)	Cynomolgus monkeys	EC50	~140 nM	[1]
In vitro whole blood assay (pAKT)	Cynomolgus monkeys	IC50	84 nM	[1]

## Experimental Protocols

### PI3K Isoform Selectivity in Cellular Assays

Objective: To determine the cellular selectivity of CDZ173 for PI3K $\delta$  over other Class I isoforms.

Methodology:

- Cell Lines: Rat-1 fibroblasts were transfected with constructs expressing human myr-p110 PI3K isoforms ( $\alpha$ ,  $\beta$ ,  $\delta$ ). U937 human monocytic cells were used to assess PI3K $\gamma$  activity.[1]
- PI3K $\alpha$ ,  $\beta$ ,  $\delta$  Assay:
  - Transfected Rat-1 cells were treated with varying concentrations of CDZ173.
  - The phosphorylation of AKT (pAKT), a downstream marker of PI3K activity, was measured as the readout.[1]
  - IC50 values were calculated to determine the inhibitory potency against each isoform.
- PI3K $\gamma$  Assay:
  - U937 monocytes were stimulated with the GPCR ligand MIP-1 $\alpha$  to induce PI3K $\gamma$ -dependent activation.[1]
  - Cells were co-treated with a range of CDZ173 concentrations.
  - The inhibitory effect on monocyte activation was quantified to determine the IC50 for PI3K $\gamma$ . [1]

### In Vivo Assessment of B-cell Activation

Objective: To evaluate the in vivo efficacy of CDZ173 in inhibiting B-cell activation.

Methodology:

- Animal Models: Rats and cynomolgus monkeys were used.[1]

- Procedure:
  - Animals were orally administered CDZ173 at various doses (e.g., 3-30 mg/kg twice daily for 4 weeks in rats).[8]
  - Blood samples were collected at different time points.
  - Ex vivo stimulation of B-cells was performed using anti-IgM and IL-4.[1]
  - The phosphorylation of AKT (pAKT) in CD20+ B-cells was measured by flow cytometry to assess the level of B-cell activation.[1]
  - Concentration- and time-dependent inhibition of B-cell activation was determined.[1]

## Visualizing the Mechanism of Action

### CDZ173 Signaling Pathway

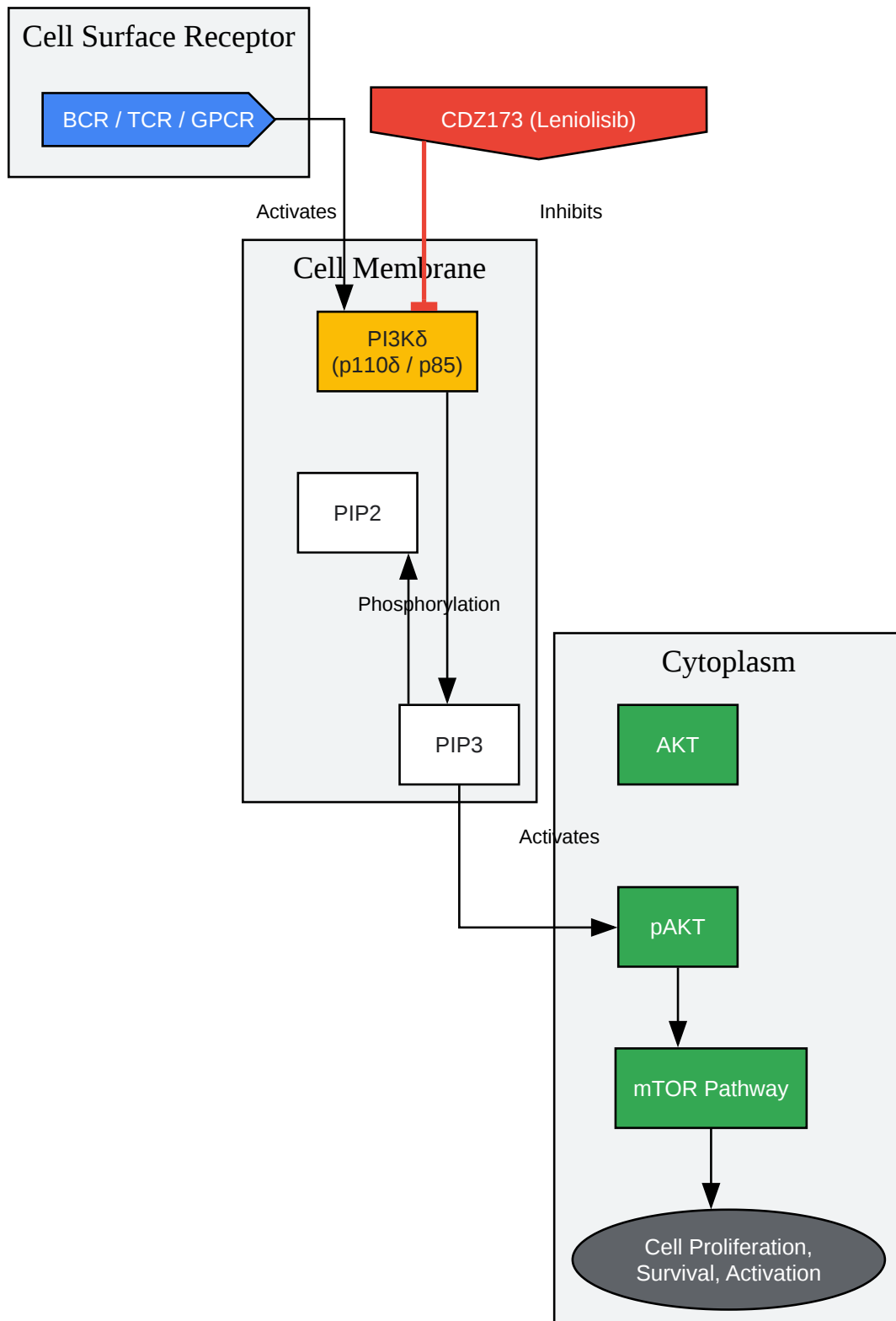

[Click to download full resolution via product page](#)

Caption: CDZ173 inhibits PI3K $\delta$ , blocking PIP3 production and downstream AKT/mTOR signaling.

## Experimental Workflow for Cellular Selectivity Assay

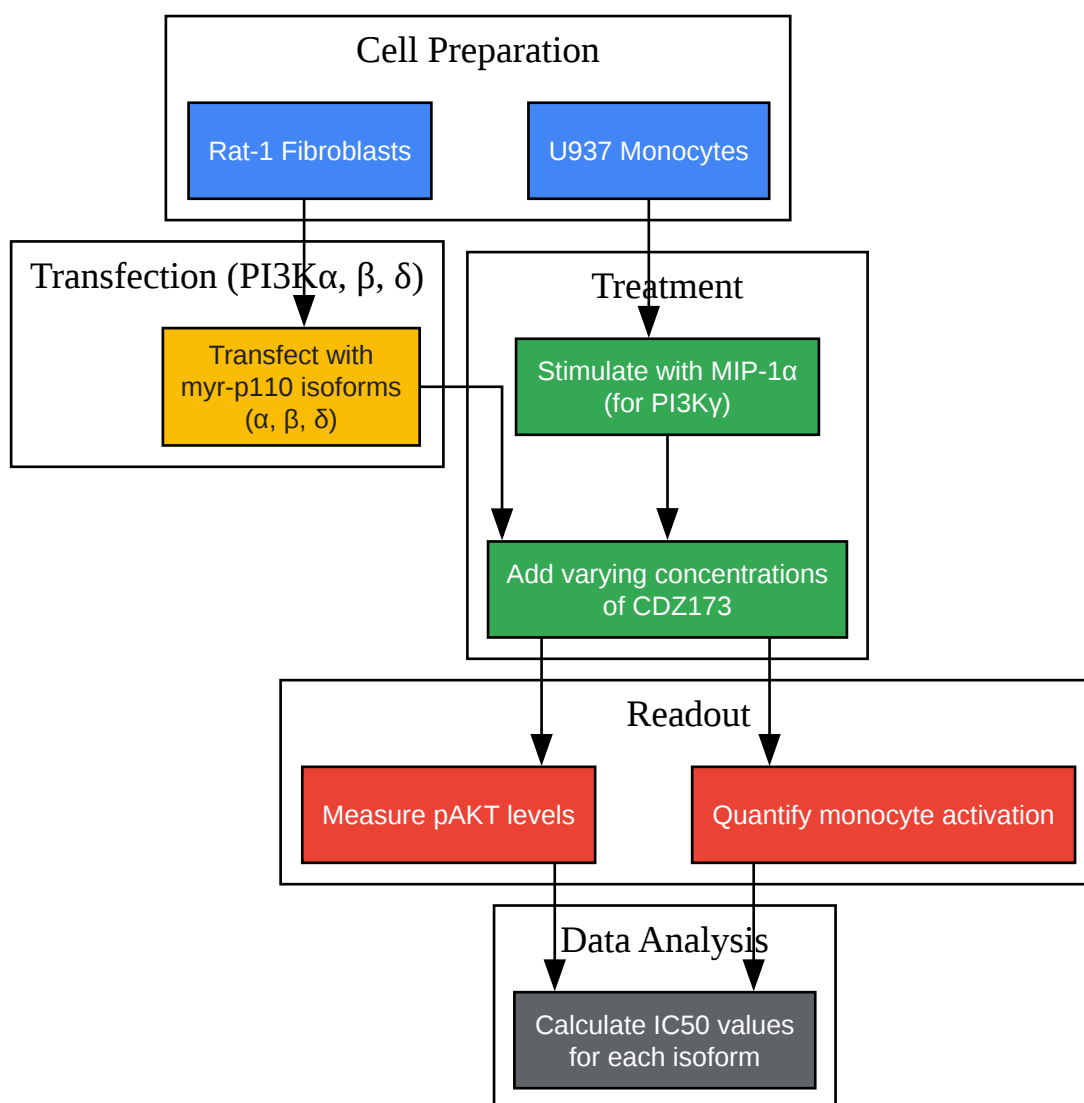

[Click to download full resolution via product page](#)

Caption: Workflow for determining the cellular selectivity of CDZ173 against PI3K isoforms.

## Conclusion

CDZ173 (leniolisib) is a highly selective and potent inhibitor of the PI3K $\delta$  enzyme. Its mechanism of action is well-defined, involving direct binding to the ATP pocket of the p110 $\delta$

subunit, leading to the suppression of the PI3K/AKT/mTOR signaling pathway. This targeted approach effectively normalizes the hyperactive signaling characteristic of APDS, leading to the amelioration of immune dysregulation. The extensive in vitro and in vivo data, including clinical trial results, provide a robust foundation for its therapeutic use in APDS and its potential exploration in other immune-mediated disorders.[1][4][14]

### Need Custom Synthesis?

BenchChem offers custom synthesis for rare earth carbides and specific isotopic labeling.

Email: [info@benchchem.com](mailto:info@benchchem.com) or [Request Quote Online](#).

## References

- [1. Discovery of CDZ173 \(Leniolisib\), Representing a Structurally Novel Class of PI3K Delta-Selective Inhibitors - PMC \[pmc.ncbi.nlm.nih.gov\]](#)
- [2. researchgate.net \[researchgate.net\]](#)
- [3. Discovery of CDZ173 \(Leniolisib\), Representing a Structurally Novel Class of PI3K Delta-Selective Inhibitors. | Semantic Scholar \[semanticscholar.org\]](#)
- [4. CDZ173 for Activated PI3Kdelta Syndrome · Info for Participants · Phase Phase 2 & 3 Clinical Trial 2025 | Power | Power \[withpower.com\]](#)
- [5. withpower.com \[withpower.com\]](#)
- [6. Leniolisib - Wikipedia \[en.wikipedia.org\]](#)
- [7. go.drugbank.com \[go.drugbank.com\]](#)
- [8. immune-system-research.com \[immune-system-research.com\]](#)
- [9. Effective “activated PI3Kδ syndrome”—targeted therapy with the PI3Kδ inhibitor leniolisib - PMC \[pmc.ncbi.nlm.nih.gov\]](#)
- [10. Frontiers | Leniolisib: a novel treatment for activated phosphoinositide-3 kinase delta syndrome \[frontiersin.org\]](#)
- [11. leniolisib | Ligand page | IUPHAR/BPS Guide to PHARMACOLOGY \[guidetopharmacology.org\]](#)
- [12. Phosphatidyl Inositol 3-Kinase \(PI3K\)-Inhibitor CDZ173 protects against LPS-induced osteolysis - PMC \[pmc.ncbi.nlm.nih.gov\]](#)
- [13. medchemexpress.com \[medchemexpress.com\]](#)

- [14. ClinicalTrials.gov \[clinicaltrials.gov\]](#)
- To cite this document: BenchChem. [The Core Mechanism of CDZ173 (Leniolisib): A Technical Guide]. BenchChem, [2026]. [Online PDF]. Available at: [<https://www.benchchem.com/product/b1673424/docs#the-core-mechanism-of-cdz173-leniolisib-a-technical-guide>]

---

### Disclaimer & Data Validity:

The information provided in this document is for Research Use Only (RUO) and is strictly not intended for diagnostic or therapeutic procedures. While BenchChem strives to provide accurate protocols, we make no warranties, express or implied, regarding the fitness of this product for every specific experimental setup.

**Technical Support:** The protocols provided are for reference purposes. Unsure if this reagent suits your experiment?

**Need Industrial/Bulk Grade?** [Request Custom Synthesis Quote](#)

## BenchChem

Our mission is to be the trusted global source of essential and advanced chemicals, empowering scientists and researchers to drive progress in science and industry.

### Contact

Address: 3281 E Guasti Rd

Ontario, CA 91761, United States

Phone: (601) 213-4426

Email: [info@benchchem.com](mailto:info@benchchem.com)

[Contact our Ph.D. Support Team for a compatibility check](#)