

KS 501 dosage and administration guidelines

Author: BenchChem Technical Support Team. **Date:** April 2026

Compound of Interest

Compound Name:	KS 501
CAS No.:	120634-86-8
Cat. No.:	B1673849

[Get Quote](#)

Application Notes and Protocols: KS-501

For Research Use Only. Not for use in diagnostic procedures.

Introduction

KS-501 is an investigational, first-in-class bispecific antibody biopolymer conjugate (ABC) developed by Kodiak Sciences.[1][2] It is designed for the treatment of retinal vascular diseases by simultaneously targeting two key pathways involved in their pathogenesis: vascular endothelial growth factor (VEGF) and interleukin-6 (IL-6).[1][3] This document provides a summary of the available preclinical and clinical data on KS-501, along with representative protocols for key experiments relevant to its evaluation.

Mechanism of Action

KS-501 is engineered to provide potent, dual inhibition of angiogenesis and inflammation.[1] Its structure consists of a trap-antibody fusion protein conjugated to a phosphorylcholine-based biopolymer.[4][5][6] This design allows for a dual mechanism of action:

- **Anti-VEGF Activity:** A soluble decoy receptor component binds to and inhibits VEGF-A and Placental Growth Factor (PLGF), preventing them from binding to their cognate receptors.

This action suppresses angiogenesis (abnormal blood vessel growth) and reduces vascular permeability.[\[1\]](#)[\[3\]](#)

- Anti-IL-6 Activity: An antibody component binds to soluble IL-6, inhibiting its interaction with both soluble and membrane-bound IL-6 receptors. This interference with IL-6 signaling mitigates inflammation.[\[1\]](#)[\[3\]](#)

Preclinical studies have demonstrated that this dual inhibition provides superior normalization of endothelial cell morphology and junctional biology compared to monotherapy targeting either VEGF or IL-6 alone.[\[1\]](#)

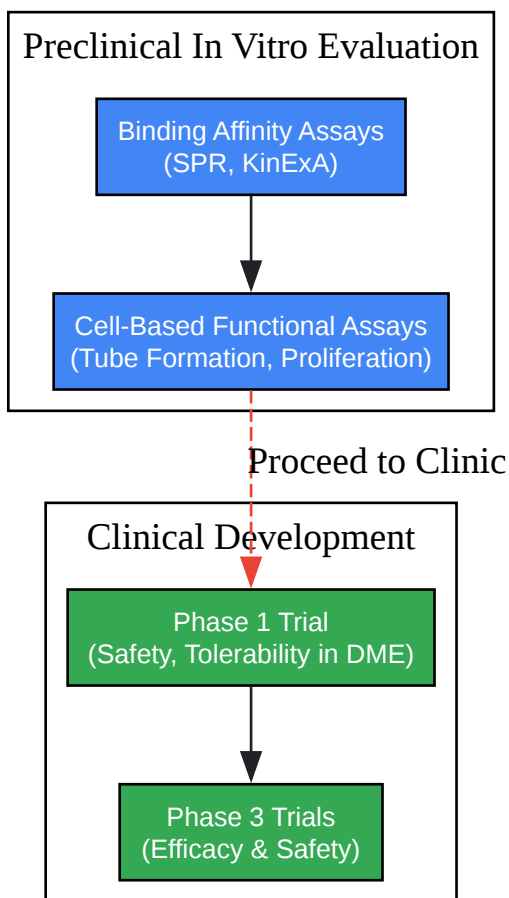
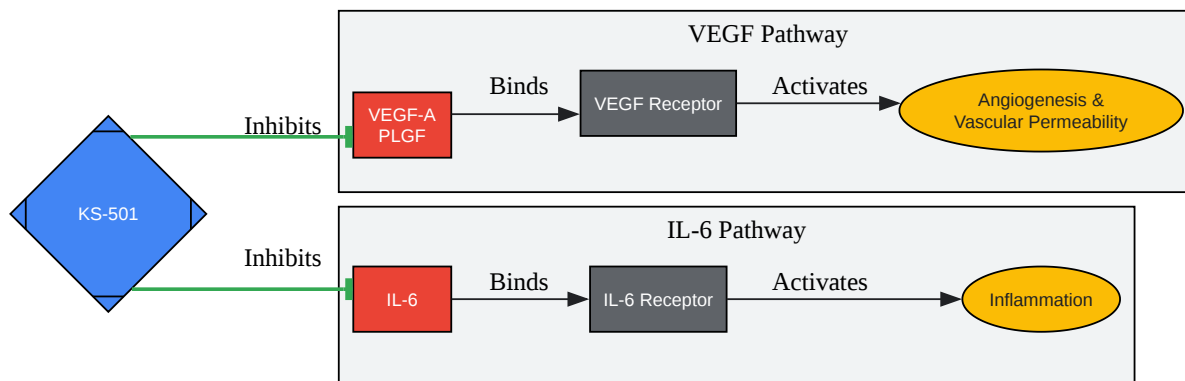

[Click to download full resolution via product page](#)

Need Custom Synthesis?

BenchChem offers custom synthesis for rare earth carbides and specific isotopic labeling.

Email: info@benchchem.com or [Request Quote Online](#).

References

- [1. kodiak.com \[kodiak.com\]](http://kodiak.com)
- [2. iovs.arvojournals.org \[iovs.arvojournals.org\]](http://iovs.arvojournals.org)
- [3. Kodiak Sciences begins subject treatment in DME therapy trial \[clinicaltrialsarena.com\]](http://clinicaltrialsarena.com)
- [4. KSI-301: antibody biopolymer conjugate in retinal disorders - PMC \[pmc.ncbi.nlm.nih.gov\]](http://pmc.ncbi.nlm.nih.gov)
- [5. KSI-501 by Kodiak Sciences for Diabetic Macular Edema: Likelihood of Approval \[pharmaceutical-technology.com\]](http://pharmaceutical-technology.com)
- [6. KSI-501 by Kodiak Sciences for Wet \(Neovascular / Exudative\) Macular Degeneration: Likelihood of Approval \[pharmaceutical-technology.com\]](http://pharmaceutical-technology.com)
- To cite this document: BenchChem. [KS 501 dosage and administration guidelines]. BenchChem, [2026]. [Online PDF]. Available at: [\[https://www.benchchem.com/product/b1673849/docs#ks-501-dosage-and-administration-guidelines\]](https://www.benchchem.com/product/b1673849/docs#ks-501-dosage-and-administration-guidelines)

Disclaimer & Data Validity:

The information provided in this document is for Research Use Only (RUO) and is strictly not intended for diagnostic or therapeutic procedures. While BenchChem strives to provide accurate protocols, we make no warranties, express or implied, regarding the fitness of this product for every specific experimental setup.

Technical Support: The protocols provided are for reference purposes. Unsure if this reagent suits your experiment?

Need Industrial/Bulk Grade? [Request Custom Synthesis Quote](#)

BenchChem

Our mission is to be the trusted global source of essential and advanced chemicals, empowering scientists and researchers to drive progress in science and industry.

Contact

Address: 3281 E Guasti Rd
Ontario, CA 91761, United States
Phone: (601) 213-4426
Email: info@benchchem.com

[Contact our Ph.D. Support Team for a compatibility check](#)