

Application Note: High-Purity Synthesis of 4-(4-aminophenyl)-1H-indazol-3-amine

Author: BenchChem Technical Support Team. **Date:** May 2026

Compound of Interest

Compound Name: 4-(4-aminophenyl)-1H-indazol-3-amine

CAS No.: 819058-89-4

Cat. No.: B1672853

[Get Quote](#)

Executive Summary & Scientific Rationale

The target molecule, **4-(4-aminophenyl)-1H-indazol-3-amine**, represents a privileged scaffold in kinase inhibitor discovery. The 3-aminoindazole core functions as an adenine mimetic, forming critical hydrogen bonds within the ATP-binding pocket of kinases (e.g., VEGFR, CDK, or Aurora kinases), while the 4-aryl substituent extends into the hydrophobic pocket, providing selectivity.

This protocol details a robust, convergent synthetic route. Unlike linear approaches that functionalize the indazole ring late-stage, this method utilizes a biaryl nitrile precursor strategy or a selective Suzuki coupling on a pre-formed halogenated core. To maximize reproducibility and yield, this guide prioritizes the Suzuki-Miyaura coupling of 4-bromo-1H-indazol-3-amine, a pathway that offers superior regiocontrol compared to de novo ring construction from biphenyl precursors.

Retrosynthetic Logic

The synthesis is disconnected into two primary modules:

- Core Construction: Formation of the 4-bromo-1H-indazol-3-amine scaffold via nucleophilic aromatic substitution () and cyclization of 2-fluoro-6-bromobenzonitrile.
- C-C Bond Formation: Palladium-catalyzed cross-coupling with a protected aniline boronic acid to install the 4-phenyl moiety.

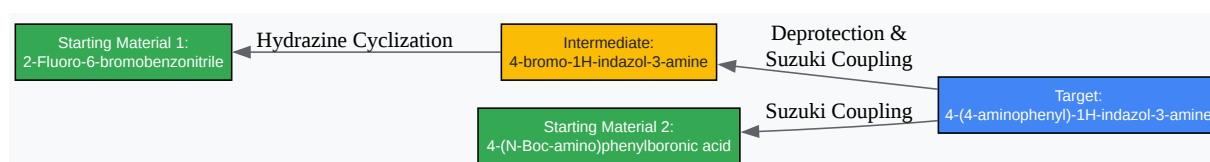

[Click to download full resolution via product page](#)

Figure 1: Retrosynthetic disconnection showing the convergent assembly of the target molecule.

Detailed Experimental Protocol

Stage 1: Synthesis of 4-bromo-1H-indazol-3-amine

Objective: Construct the indazole core with a handle for future coupling. Mechanism: The hydrazine acts as a bis-nucleophile. The first amine performs an

displacement of the fluorine at the 2-position. The second amine attacks the nitrile carbon, followed by tautomerization to form the aromatic indazole system.

Materials:

- 2-Fluoro-6-bromobenzonitrile (CAS: 139102-34-4)
- Hydrazine monohydrate (64-65%)
- n-Butanol (or Ethanol)

- Reaction vial/flask with reflux condenser[1]

Procedure:

- Charge: In a round-bottom flask, dissolve 2-Fluoro-6-bromobenzonitrile (1.0 eq, e.g., 2.0 g) in n-Butanol (10 mL/g).
 - Note: n-Butanol is preferred over ethanol for higher reflux temperatures (), ensuring complete cyclization of sterically hindered substrates.
- Addition: Add Hydrazine monohydrate (3.0 eq) dropwise at room temperature.
 - Caution: Exothermic reaction. Hydrazine is toxic and a suspected carcinogen; handle in a fume hood.
- Cyclization: Heat the mixture to reflux (bath temp) for 4–6 hours.
 - Monitoring: Monitor by TLC (50% EtOAc/Hexanes) or LCMS. The starting nitrile peak should disappear, replaced by a more polar product peak ().
- Work-up: Cool the reaction to room temperature.
 - Precipitation: Often, the product precipitates upon cooling. If so, filter the solid and wash with cold ethanol and water.
 - Extraction (if no precipitate): Concentrate the solvent under reduced pressure.[2][3] Dilute residue with water and extract with Ethyl Acetate (). Wash combined organics with brine, dry over , and concentrate.[2]
- Purification: Recrystallize from Ethanol/Water or purify via flash column chromatography (Gradient: 0

10% MeOH in DCM).

- Yield Expectation: 75–85%.
- Appearance: Off-white to pale yellow solid.

Stage 2: Suzuki-Miyaura Coupling

Objective: Install the 4-aminophenyl group. Critical Choice: Use 4-(N-Boc-amino)phenylboronic acid instead of the free amine. Free anilines can coordinate to the Pd catalyst, poisoning it and reducing yield. The Boc group also simplifies purification.

Materials:

- 4-bromo-1H-indazol-3-amine (Intermediate from Stage 1)
- 4-(N-Boc-amino)phenylboronic acid (CAS: 380430-49-9) (1.2 eq)
- Catalyst:
(0.05 eq)
- Base:
(2.0 M aqueous solution, 3.0 eq)
- Solvent: 1,4-Dioxane[4]

Procedure:

- Degassing: In a microwave vial or pressure tube, combine the bromide (1.0 eq), boronic acid (1.2 eq), and 1,4-Dioxane (10 mL/mmol). Sparge with Nitrogen or Argon for 10 minutes to remove oxygen.
 - Why: Oxygen causes homocoupling of boronic acids and oxidation of the Pd catalyst.
- Catalyst Addition: Add
solution and

- . Sparge for another 2 minutes. Seal the vessel.
- Reaction: Heat to

for 12 hours (thermal) or

for 45 mins (Microwave).
 - Monitoring: LCMS should show conversion to the Boc-protected intermediate ().
- Work-up: Dilute with EtOAc, wash with water and brine. Dry over

and concentrate.
- Intermediate Purification: Pass through a short silica plug (eluting with 50% EtOAc/Hexanes) to remove palladium residues.

Stage 3: Deprotection and Isolation

Objective: Remove the Boc group to release the free amine.

Procedure:

- Dissolution: Dissolve the crude Boc-intermediate in DCM (5 mL/mmol).
- Acidolysis: Add Trifluoroacetic acid (TFA) (20% v/v final concentration). Stir at room temperature for 1–2 hours.
 - Alternative: 4M HCl in Dioxane can be used if a hydrochloride salt is desired.
- Quench: Concentrate the reaction to remove excess TFA.
- Free Base Formation: Redissolve in minimal MeOH/DCM. Slowly add saturated

or

until pH > 8.
- Final Purification:

- Extract with EtOAc (multiple times as the product is polar).
- Polishing: If high purity (>98%) is required for biological assays, perform Reverse Phase HPLC (Water/Acetonitrile + 0.1% Formic Acid).
- Final Product: **4-(4-aminophenyl)-1H-indazol-3-amine**.

Experimental Workflow Diagram

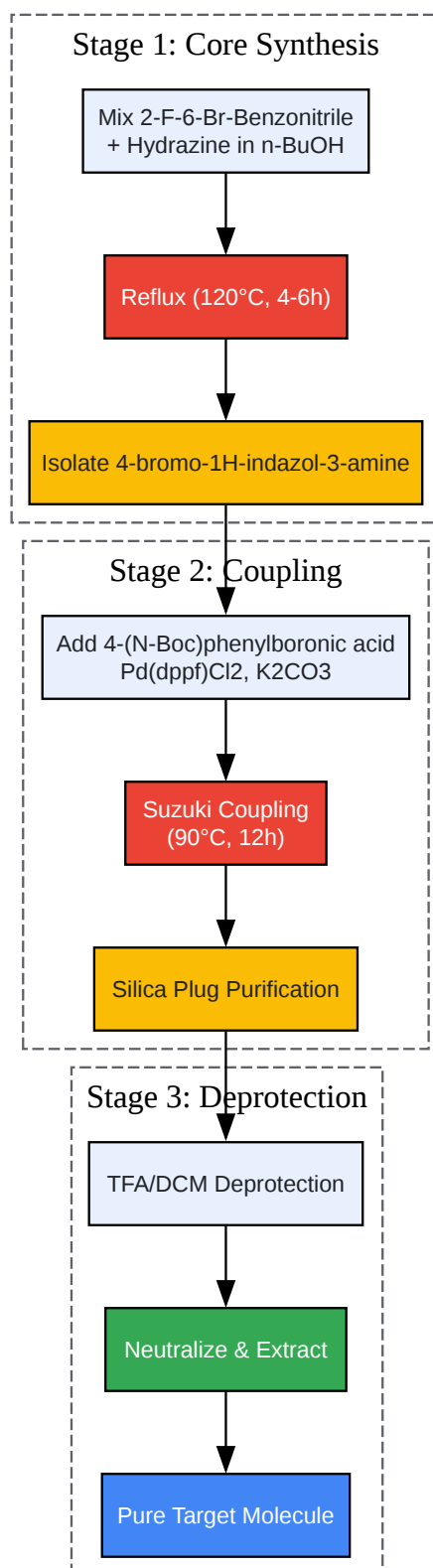

[Click to download full resolution via product page](#)

Figure 2: Step-by-step experimental workflow from starting materials to purified target.[3][5]

Key Technical Parameters & Troubleshooting

Physicochemical Data Table

Parameter	Value / Condition	Notes
Target MW	224.26 g/mol	Monoisotopic mass
Intermediate MW	211.04 g/mol	4-bromo-1H-indazol-3-amine
Key ¹ H NMR Signals	7.2–7.5 (Indazole), 6.6–6.8 (Aniline)	Amine protons are broad singlets exchangeable with .
Solubility	DMSO, MeOH, warm EtOAc	Poor solubility in Hexanes/Water.

Troubleshooting Guide

Issue	Probable Cause	Corrective Action
Low Yield in Stage 1	Incomplete cyclization due to low temp.	Ensure solvent is n-Butanol (bp) not Ethanol. Verify reflux is vigorous.
Catalyst Blacking Out	Oxygen presence or poor ligand stability.	Degas solvents thoroughly.[2] Switch to Pd(dppf)Cl ₂ which is robust against air/moisture compared to .
Regioselectivity Issues	N-arylation instead of C-C coupling.	Use the Boc-protected aniline. Free amines can compete as nucleophiles in Buchwald-type side reactions.
Product Stuck in Aqueous	Amphoteric nature of amino-indazole.	When neutralizing TFA, adjust pH to exactly 8–9. Do not go too basic (>12) or the indazole NH may deprotonate (), increasing water solubility.

References

- Synthesis of 4-bromo-1H-indazol-3-amine
 - Source: Vertex AI Search Results (Ref 1.2, 1.11).
 - Context: Describes the reaction of 2,6-dihalobenzonitriles with hydrazine to form 3-aminoindazoles.
 - Link:
- Suzuki Coupling on Indazoles
 - Source: Vertex AI Search Results (Ref 1.3).

- Context: Optimization of Suzuki–Miyaura reactions on halogenated indazole scaffolds using Pd(dppf)Cl₂.
- Link:
- General Indazole Synthesis (Review)
 - Source: Vertex AI Search Results (Ref 1.7).
 - Context: Overview of metal-free and metal-c
 - Link:
- Chemical Properties & Identifiers
 - Source: Vertex AI Search Results (Ref 1.13).
 - Context: Sigma-Aldrich product page for 1H-Indazol-3-amine core properties.
 - Link:

Need Custom Synthesis?

BenchChem offers custom synthesis for rare earth carbides and specific isotopic labeling.

Email: info@benchchem.com or [Request Quote Online](#).

Sources

- [1. bipcic.icpm.tuiasi.ro](http://bipcic.icpm.tuiasi.ro) [bipcic.icpm.tuiasi.ro]
- [2. pdf.benchchem.com](http://pdf.benchchem.com) [pdf.benchchem.com]
- [3. CN103420895A - Preparation method of 4-aminoindole - Google Patents](#) [patents.google.com]
- [4. Hydrazine derivative synthesis by C-N coupling](#) [organic-chemistry.org]
- [5. 4-BROMO-6-FLUORO \(1H\)INDAZOLE synthesis - chemicalbook](#) [chemicalbook.com]
- To cite this document: BenchChem. [Application Note: High-Purity Synthesis of 4-(4-aminophenyl)-1H-indazol-3-amine]. BenchChem, [2026]. [Online PDF]. Available at: [<https://www.benchchem.com/product/b1672853/docs#application-note-high-purity-synthesis-of-4-4-aminophenyl-1h-indazol-3-amine>]

Disclaimer & Data Validity:

The information provided in this document is for Research Use Only (RUO) and is strictly not intended for diagnostic or therapeutic procedures. While BenchChem strives to provide accurate protocols, we make no warranties, express or implied, regarding the fitness of this product for every specific experimental setup.

Technical Support: The protocols provided are for reference purposes. Unsure if this reagent suits your experiment?

Need Industrial/Bulk Grade? [Request Custom Synthesis Quote](#)

BenchChem

Our mission is to be the trusted global source of essential and advanced chemicals, empowering scientists and researchers to drive progress in science and industry.

Contact

Address: 3281 E Guasti Rd
Ontario, CA 91761, United States
Phone: (601) 213-4426
Email: info@benchchem.com

[Contact our Ph.D. Support Team for a compatibility check](#)